

PLAN Series™

Physical Planning Manual

NESTAR



NESTAR SYSTEMS, INCORPORATED

PLAN SERIES™

PHYSICAL PLANNING MANUAL

DISCLAIMER OF WARRANTIES

The information in this document has been carefully reviewed and is believed to be reliable; nevertheless, Nestar Systems, Incorporated, makes no warranties, either express or implied, with respect to this manual or with respect to the software described in this manual, its quality, performance, merchantability, or fitness for any particular purpose. The entire risk as to its quality and performance is with the buyer. The software described herein transferred "AS IS."

Nestar Systems, Incorporated, reserves the right to make changes to any products described herein to improve their functioning or design. Nestar programs are licensed products whose use is defined in the Nestar Systems Software License Agreement. Server Programs usually require a separate license for each machine on which they run.

In no event will Nestar Systems, Incorporated, be liable for direct, indirect, incidental, or consequential damages at law or in equity resulting from any defect in the software, even if Nestar Systems, Incorporated, has been advised of the possibility of such damages. Some states do not allow the exclusion or limitation of implied warranties or liability for incidental or consequential damages, so the above limitation or exclusion may not apply to you.

Warning

This equipment generates, uses, and can radiate radio frequency energy. If not installed and used in accordance with the manufacturer's instructions, it may cause interference to radio communications. It has been tested and found to comply with the limits for a Class A computing device pursuant to Subpart J of Part 15 of FCC Rules, which are designed to provide reasonable protection against such interference when operated in a commercial environment. Operation of this equipment in a residential area is likely to cause interference, in which case the user at his own expense will be required to take whatever measures may be required to correct the interference.

The Regents of the University of California, Apple Computer, Inc., and International Business Machines, Inc., make no warranties, either express or implied, regarding the computer software programs described herein, their merchantability or their fitness for any particular purpose. PLAN Series, PLAN File Server, PLAN 1000, PLAN 3000, PLAN 4000, PLAN 5000, Print Server Feature Card, PLANPak, and The Messenger are trademarks of Nestar Systems, Inc. UCSD, UCSD Pascal, and UCSD p-System are all trademarks of the Regents of the University of California.

This document is copyrighted and all rights are reserved. This document may not, in whole or part, be copied, photocopied, reproduced, translated, or reduced to any electronic medium or machine-readable form without prior consent, in writing, from Nestar Systems, Incorporated.

Copyright 1981 thru 1986 by Nestar Systems, Inc.
2585 E. Bayshore Rd., Palo Alto, California, 94303
(415) 493-2223 Telex 171420 Nestar PLA

Publication number GA40-0104-1
All rights reserved.
February 1, 1986

How to Use This Manual

This manual has been written to assist you in planning and completing the installation of your PLAN system. For an overview of the system, read the *PLAN Series General Information Manual*.

Chapter 1 of this manual discusses the network in a general way, describing hardware components. Chapter 2 discusses topological and environmental considerations for your network layout. When installing your network, use the *PLAN 3000 (or 4000 or 5000) Quick Installation Guide* and the PLAN Series Network Installation Manual.

The *PLAN Series General Index* indexes the contents of six core PLAN Series manuals.

A bibliography of PLAN Series system manuals and guides will be found at the end of this manual.

We welcome criticisms and suggestions. Forms for reporting program errors and documentation errors or inadequacies are provided at the back of this manual.



Contents

Disclaimer ii

How to Use This Manual iii

Contents v

Figures List vi

Tables List vi

Chapter 1 General Principles

1.0 Introduction 1-1

1.1 Definitions 1-2

Chapter 2 Physical Layout

2.0 Network Topology: HUBs and Passive HUBs 2-1

2.1 HUB and Passive HUB Placement 2-6

2.1.1 HUB Placement and Troubleshooting 2-7

2.2 Cable Placement 2-9

2.2.1 Walls, Floors, Ceilings 2-11

2.2.2 Fire Codes and Other Codes 2-11

2.2.3 BNC Wall Sockets 2-11

2.3 Servers 2-14

2.3.1 File Server Placement and Configuration 2-14

2.3.2 Other Servers 2-14

2.3.3 Print Server Feature Card 2-15

Appendix A Hardware Components A-1

Appendix B Propagation Delays B-1

CONTENTS

Index IN-1

Bibliography BB-1

Reader Comment Form Back Page

Figures List

- 2-1 Example of Topology Using 6-port HUB Box 2-2
- 2-2 Network with Multiple HUBs 2-4
- 2-3 Network with Active HUB and Passive HUB 2-5
- 2-4 HUB Placement and Troubleshooting 2-8
- 2-5 Cable Lengths 2-13

Tables List

- A-1 93-ohm Coaxial Cables A-3
- B-1 Calculation of Propagation Delay B-1

Chapter 1

General Principles

1.0 Introduction

The PLAN systems connect up to 255 network stations. The systems are easy to install, and this manual does not assume that you have any specialized technical knowledge. Nevertheless you will find it helpful to read the *PLAN Series General Information Manual* before beginning. A general knowledge of microcomputers is also desirable.

File servers are network stations (or nodes) with special hardware and software that allow network users to share hard disk storage and programs. Desktop file servers support one 5.25" hard disk.

Floor-standing file servers consist of a cabinet labeled "File Server" and from none to four cabinets labeled "Storage." The file server cabinet contains the server controller hardware, a cartridge tape backup subsystem, power supplies, and a disk/tape controller. An 8" hard disk and its power supply are optional for the first cabinet of the floor-standing model. The desktop model contains a 5.25" hard disk. Also optional are Print Server Feature Cards (one card per desktop model; one or two cards per floor-standing model).

User stations and server stations are connected to the network by industry standard RG62/U coaxial cable, fiber optic cable, or IBM Cabling System cable. Installation of user stations consists of laying out cable and HUBs (defined in Section 1.1), installing Network Interface cards (NICs) in the workstations, and attaching them to the cable.

Network installation is described in detail in the *PLAN 3000 (or 4000 or 5000) Quick Installation Guide* and the *PLAN Series Network Installation Reference Manual*. Before installation begins, however, some planning of network layout is necessary.

Hardware components are listed in Appendix A.

PRINCIPLES

1.1 Definitions

Server – a generic term referring to any network station that performs some function on behalf of other network stations. The server generally consists of three functional units: server software, server hardware, and a shared resource (disk, printer, modem, etc.).

File Server – hardware and software that control access to network disk storage (up to four hard disks for the floor-standing model) and system backup.

File Server cabinet – the cabinet containing a power supply, tape drive, hard disk (optional for the PLAN 4000), and optional servers.

Storage cabinet – labeled "Storage". Contains a 14" hard disk and power supply (PLAN 4000 file server).

HUB – a line isolation device that splits the network signal. The HUB is a small box, located in an accessible place outside the controller cabinets or workstations, with multiple network ports to which workstations, server controllers, and other HUBs attach via network cable. HUBs can be active or passive.

Active HUB – a line isolation device that splits and regenerates the network signal. Each user workstation and server controller station on the network must be connected to a HUB by network cable. Active HUBs contain 6 or 16 ports. None, one, two, or all of the ports attach to fiber optic cable, depending upon the HUB model; the rest of the ports attach to coaxial or IBM Cabling System cable.

Passive HUB – a HUB that splits the network signal but does not boost or condition it. Passive HUBs contain four ports and cannot connect to fiber optic cable.

Node – any user workstation or server hardware station on the network.

NIC – Network Interface Card. Installed in a workstation computer's expansion slot, the NIC connects the computer via cable to a HUB and thus to the network.

PIC – Peripheral Interface Card. Part of the file server. Contains Network Interface, Clock/Calendar with battery backup, and disk/tape interface.

Print Server Feature Card – an auxiliary processor installed in the file server that runs the PLAN Series print server software. It includes an onboard passive HUB.

Cable connector – various types of connectors that attach HUBs and nodes to network cable. For example, BNC connectors are circular twist-lock connectors. Male connectors are used to terminate cables and to attach to female connectors on the equipment. Fiber optic connectors are circular screw type (SMA) connectors used to attach RAYCOM fiber optic cable to HUBs and nodes.



Chapter 2

Physical Layout

2.0 Network Topology: HUBs and Passive HUBs

At least one HUB is required to connect nodes (workstations or servers) to the network

HUBs are separately packaged boxes available in active and passive forms:

- the active HUB contains 6 to 16 ports, to which nodes and other HUBs are attached using coaxial, fiber optic, or IBM Cabling System cable. None, one, two, or all of the ports connect to fiber optic cable, depending upon the HUB model; the other ports connect to coaxial or IBM Cabling System cable.
- the passive HUB contains four ports to which nodes or active HUBs are attached via coaxial or IBM Cabling System twisted pair cable. Passive HUBs cannot be connected to each other, used with long cable runs, or used with fiber optic cable.
- a passive HUB is also onboard the Print Server Feature Card. This HUB connects the print server and file server to the network (see Section 2.3.3).

An example of a small network is shown in Figure 2-1.

Figure 2-1
Example of Topology
Using 6-port HUB Box

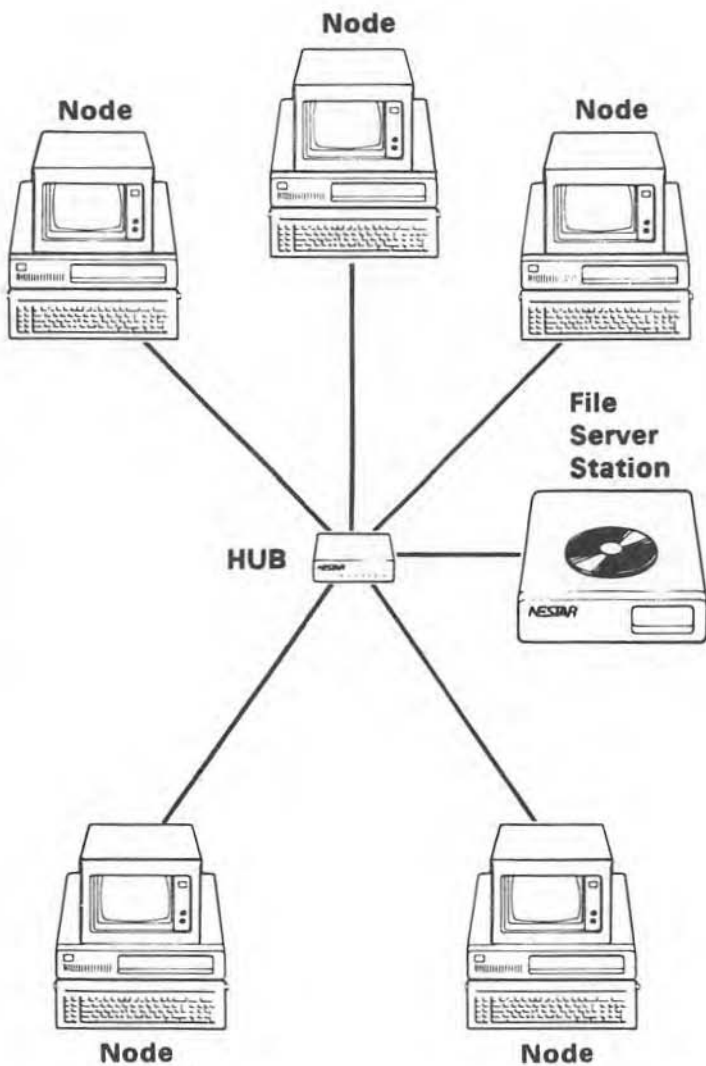

Note that each node has a coaxial cable, fiber optic cable, or IBM Cabling System cable running between it and the HUB. It is not possible to combine multiple nodes on a single cable run to the HUB. All ports on a HUB do not have to be used (although, if unused, the ports on a passive HUB must be terminated by a resistor). Additional nodes or HUBs can be added as a network expands.

The connection of the file server to the network requires the use of one port on a HUB.

The HUB pictured in Figure 2-1 is a 6-port HUB with a node connected to every port. More stations can be added by

- (1) substituting a 16-port HUB for the 6-port HUB, thus providing additional ports for node connection, or
- (2) disconnecting one of the nodes from the HUB, attaching a cable run from the first HUB to a second HUB, and reattaching the node to the second HUB. In this way networks with up to 255 nodes can be created by connecting HUBs together.

Examples of multiple HUB networks are shown in Figures 2-2 and 2-3.

Figure 2-2
Network Using Multiple HUBs

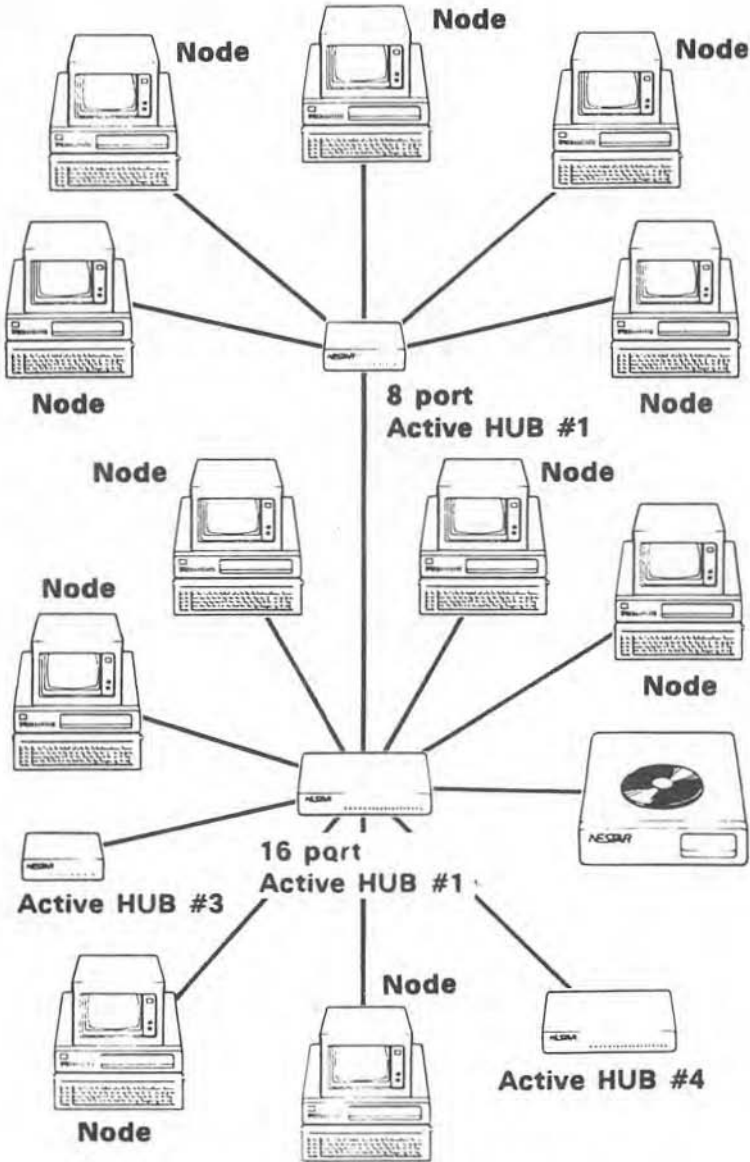
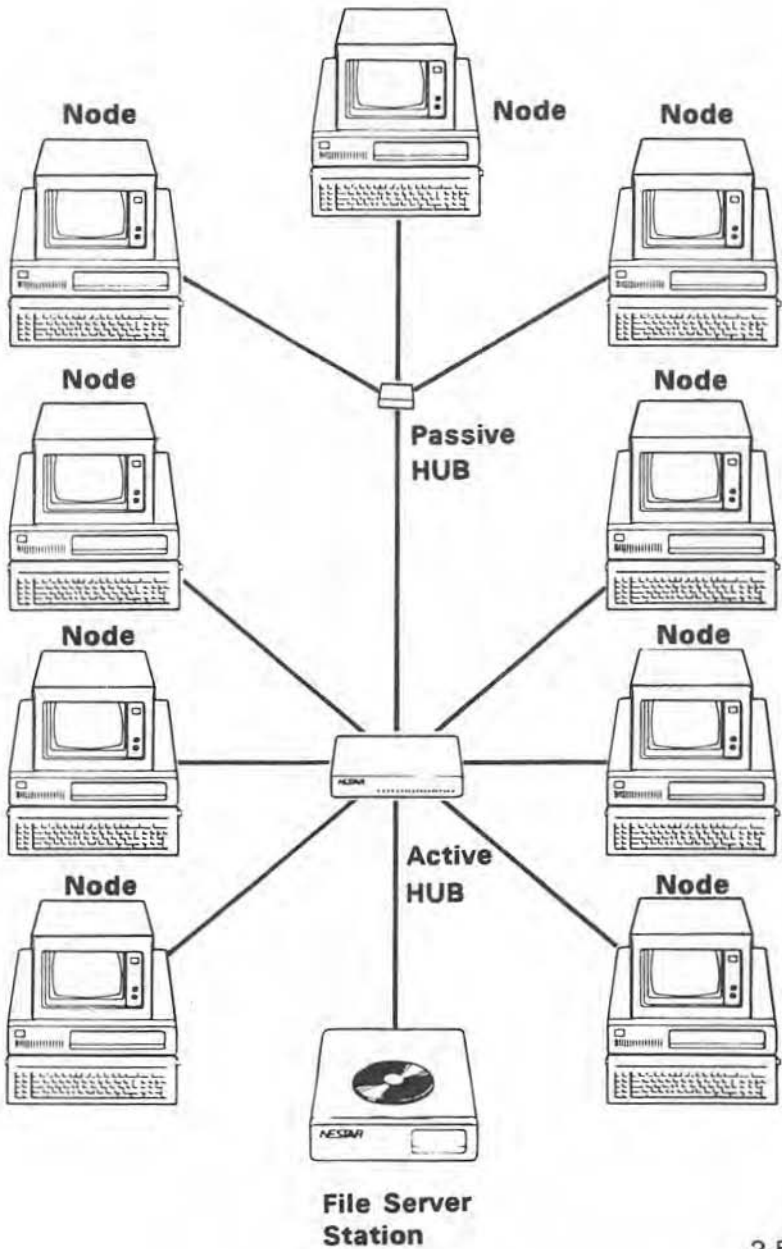

Figure 2-3

Network with Active HUB and Passive HUB



2.1 HUB and Passive HUB Placement

Cable length and interconnection rules between HUBs and nodes are discussed in Section 2.2. Print Server Feature Card connection rules are discussed in Section 2.3.3. HUB placement for efficient troubleshooting is discussed in Section 2.1.1.

Plan the location of HUBs and nodes to minimize the total amount of cable. Physically place the HUB(s) closest to the largest concentration of nodes. For example, if there are ten nodes physically close to each other and 2 nodes that are some distance from this cluster, optimum HUB placement is near the ten clustered nodes. There are then only two long cable runs required from the two distant nodes to the HUB. Cable runs between the HUB and the ten nearby nodes will be relatively short.

In networks with multiple HUBs the same principle applies. HUBs should be placed near the greatest concentration of nodes so that long cable runs are kept to a minimum.

Active HUBs require 110 Vac (United States) or 220/240 Vac (European) power from a grounded outlet on a clean circuit (though a dedicated circuit is not necessary). Clean electrical circuits are circuits that have no other electro-mechanical equipment on them (such as typewriters, copy machines, or heavy machinery).

HUBs can be placed in a variety of places in a building: in an electrical closet, for example, or in a room corner on the floor or on a shelf, providing the environmental conditions do not exceed those specified (5°-40° C ambient, 10-85% humidity non-condensing). If more than one HUB is present, they should not be stacked unless a fan is present to move air past their vents. The cables coming out of them can be hidden. There should be easy access to a clean AC power circuit. Since physical access to each HUB may be required for servicing the network, HUBs should not be placed where accessibility is difficult or impossible for the service technician.

HUBs can be grouped together if necessary to provide ease of access or spread out to minimize cable runs. In some cases, network signals on coaxial or twisted-pair cables may be affected by external electromagnetic radiation. Signals on fiber optic cable are not affected by such radiation.

2.1.1 HUB Placement and Troubleshooting

Suppose that a workstation, HUB, or section of cable is faulty and causing problems on the network. The faulty component is most efficiently found if the network has been laid out with a central, easily-accessible HUB, any other necessary HUBS radiating from it in a spokelike fashion (Figure 2-4) and located, for example, in other buildings.

Each peripheral HUB can then be disconnected in turn to isolate the failing section. The central HUB should be easily accessible in a well-lit place since initial troubleshooting activities will focus on it.

To check the cable to a suspect section, replace the peripheral HUB with an IBM PC using the COUNT utility program found in Chapter 5 of the *PLAN Series IBM PC DOS Reference Manual*.

If additional HUBs are necessary, locate the HUBs peripheral to the central HUB in an environment similar to that of the central HUB.

Figure 2-4

HUB Placement and Troubleshooting

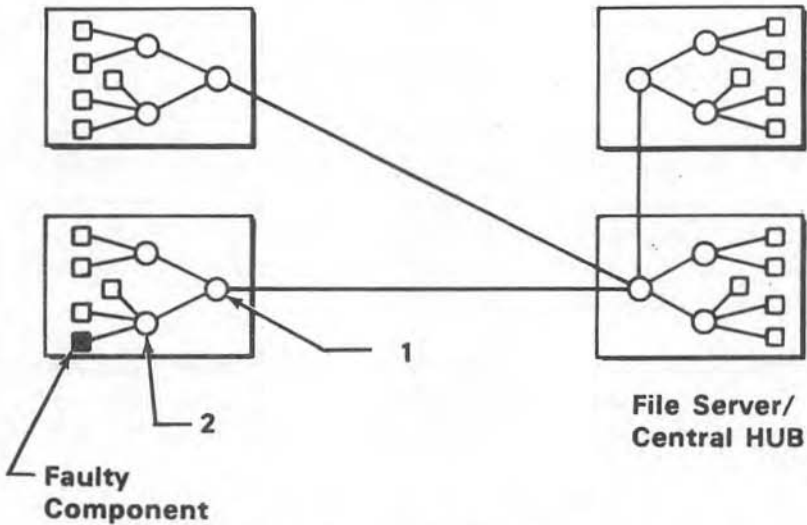

EFFICIENT NETWORK LAYOUT FOR ISOLATION OF FAULTY COMPONENT (2 MOVES)

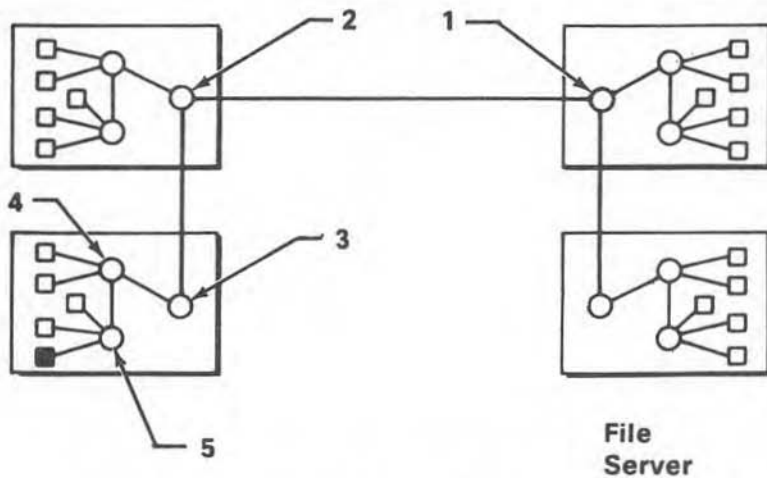

INEFFICIENT NETWORK LAYOUT FOR ISOLATION OF FAULTY COMPONENT (5 MOVES)

2.2 Cable Placement

Interconnection rules:

- (1) User stations, servers, and HUBs can be connected in any topology without loops (that is, there must never be more than one cabled path from any station or HUB to any other HUB or station).
- (2) Coax cable lengths from nodes to active HUBs or between active HUBs can be up to 2000 feet. Fiber optic cable lengths can be up to 4000 feet. IBM Cabling System twisted pair cable lengths can be up to 1650 feet. (However the following rules must also be satisfied.)
- (3) No two nodes can be separated by more than 10 HUBs.
- (4) Passive HUBs must not be connected to each other without an intervening active HUB. Passive HUBs cannot connect to fiber optic cables.
- (5) No more than 200 feet of cable can be connected to a passive HUB: this includes cable to the passive HUB from active HUBs and from network stations. Cable for passive HUBs must not be coiled.

The Print Server Feature Card's (optional) onboard HUB is passive. This HUB can be cabled only to an active HUB (total cable length < 200'). Print Server Feature Card cabling rules are discussed in Section 2.3.3. The file server and any other feature card present can also be cabled to this passive onboard HUB.

- (6) The maximum distance between any two nodes or HUBs in a network (including intervening HUBs) is 22,000 feet (over 4 miles) for coaxial cable or 17,000 feet for fiber optic cable. Since HUBs can be arranged in star-like configurations, the total number of HUBs and total amount of cable possible in a

LAYOUT

single network is far larger than will ever be needed (more than 65,000 HUBs and 130 million feet of coaxial cable).

- (7) Signal propagation time between any two stations on the network cannot exceed 32 microseconds. For networks that use only coax and/or twisted-pair cables, the 10-Hub cable-length restrictions above allow adequate propagation time.

However propagation times through fiber optic cable are greater. When laying out a network that includes fiber optic cable, calculate the propagation time between the nodes farthest apart (in terms of cable and number of intervening HUBs) as follows:

$$\begin{aligned} \text{Prop. time} = & \text{total length of twisted pair cable (ft) x .0013} \\ & + \text{total length of coax (ft) x .00121} \\ & + \text{total length of optic cable (ft) x .00154} \\ & + \text{\# of coax/tp HUBs x .3} \\ & + \text{\# of fiber optic HUBs x .5} \end{aligned}$$

A fiber-optic HUB joins fiber-optic to fiber-optic port or fiber-optic to coax/twisted pair port.

A worksheet for calculating propagation delays is found in Appendix B

- (8) All passive HUB ports with coaxial cable connected to them must be terminated by a resistor or by attachment to a node.

At installation time, draw a map of the network. Network workstations and server stations must have unique addresses, and these should be recorded. In addition cable runs can be given identification numbers. These addresses and ID numbers can be included on the map.

2.2.1 Walls, Floors, Ceilings

Cable can be run along walls, on floors (if a rubber mat is placed over the cable run to prevent personnel from tripping), or in ceilings. Many installations use the ceilings for long cable runs. If your building has a false ceiling, this may be the most convenient location.

Although sturdy, coaxial cables are not designed for use in environments that will subject them to high pressure or constant flexing. In such environments locate cable runs inside conduits, conduit troughs, or tunnels.

Fiber optic cables are protected by a series of plastic coverings that should be chosen according to the environment in which the cable will be used.

| Use | Covering |
|-------------------|--|
| indoor non-plenum | standard |
| indoor plenum | teflon |
| outdoor overhead | water tolerant; high tensile strength |
| outdoor duct | water tolerant |

2.2.2 Fire Codes and Other Codes

Each component of the system has been designed to conform to Underwriters Laboratory Standards 114 (Business and Appliance) and 478 (Electronics Data Processing), and to the appropriate Canadian Standards Association safety standards. Check with your local fire department for any local requirements that may need your compliance.

2.2.3 BNC Wall Sockets

Since the connectors used for external network coaxial cabling are standard BNC type connectors, a standard BNC-type female wall socket can be used with the network, allowing for a very

LAYOUT

neat installation since the BNC wall socket provides a female receptacle for the network. Use of this receptacle requires enough RG62/U coaxial cable to run from the receptacle to the workstation to be connected. The coaxial cable needs a male BNC connector on both ends. Additional HUBs can be added to the network using a wall socket, and a cluster of workstations can then be cabled to the HUB.

Figure 2-5

Cable Lengths

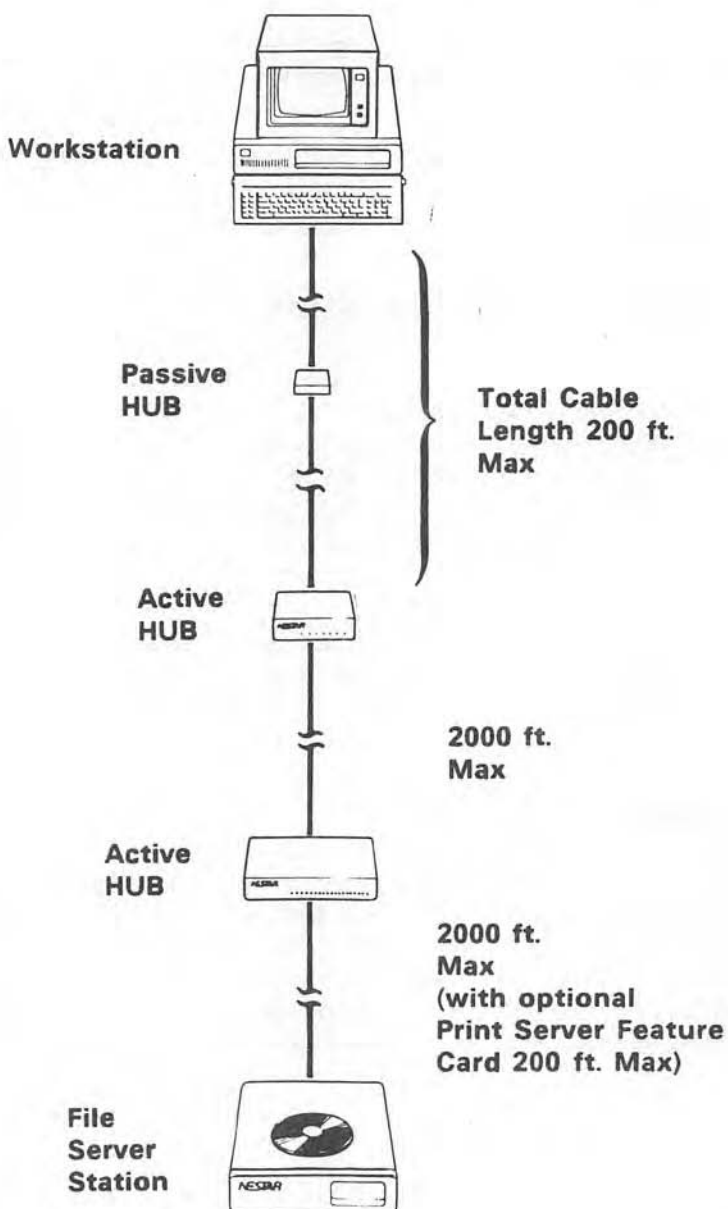

2.3 Servers

2.3.1 File Server Placement and Configuration

There are no special physical constraints on file-server placement. The file server should be placed to

- (1) maximize convenience to network system managers
- (2) minimize the danger of physical damage
- (3) allow easy access to service technicians
- (4) provide a source of clean power. File servers require 110 Vac (12 amps) (United States) or 220/240 Vac (6 amps) (European) power from a grounded outlet, on a clean circuit, though a dedicated circuit is not necessary. Clean electrical circuits have no other electro-mechanical equipment on them (such as typewriters, copy machines, or heavy machinery).
- (5) avoid excessive heat. The file server can operate in the temperature range 10°-35° C and in a relative humidity of 20-80% (non condensing).

2.3.2 Other Servers

Like the file server, other servers can be placed anywhere on the network. User convenience will be the primary consideration (for example, a print server will be placed near the greatest number of printer users). Access to required hardware (phone line and modem for communications servers, printers for print servers, etc.) will also be necessary for the specialized servers.

2.3.3 Print Server Feature Card

Print Server Feature Cards (PSFCs) have an onboard passive HUB. Maximum cable length from this HUB to an active HUB is 200 feet. The cable cannot be coiled.

Print Server Feature Card installation and details of cabling are discussed in the *PLAN Series Print Server Feature Card Installation and Operation Manual*.



Appendix A

Hardware Components

PLAN Series components include

- (1) Workstation computers
- (2) Network Interface Card for each workstation computer
- (3) HUBs: can be active or passive (see definitions in A.2).

In addition, for PLAN 3000, 4000, and 5000 systems:

- (4) Coaxial cable: any commercial grade RG62/U 93-ohm coaxial cable can be used. However, if the BNC connectors supplied with the network are to be used, outside cable diameter must equal .242 plus/minus .003 inches. The cable should be chosen with regard for environmental conditions and agency approvals. Table 1-1 shows information for some standard cables, although many others are available.

and/or

Fiber optic cable: Raycom standard 200-micron fiber cable. (Fiber optic cables cannot be used with passive hubs.)

Both kinds of cable can be used in the same network. IBM Network Cabling System cable can also be used.

- (5) File server cabinet, containing:
CPU card with memory

HARDWARE COMPONENTS

Peripheral Interface Card with

Network Interface

Clock/Calendar device(with battery backup)

Programmable interval timer

Disk and tape controller interface (handles up to four disk drives and one tape drive)

Print Server Feature Card (optional): a card installed in the file server that runs the network print server, an onboard passive HUB. One card per file server.

Eight-inch hard disk (for the PLAN 4000; this is a factory option with power supply; for the PLAN 5000, a second hard disk and power supply are optional).

5.25" hard disk (desktop model)

45 or 60MB cartridge tape drive, 90 in/sec.

Power supplies

Cooling fans

- (6) Storage cabinets contain one or two 8" (PLAN 5000) or one 14" Winchester disk (PLAN 4000) with power supply. A minimum of one disk per file server is required. Up to two (PLAN 5000) storage cabinets containing one or two 8" disks, or up to four (PLAN 4000) storage cabinets, each containing a single 14" disk can be cabled to the file server cabinet, which can also stand alone if it contains an 8" hard disk. A total of four hard disks can be supported on each floor-standing file server.
- (7) Console, used for file server and print server feature card communication.
- (8) Modems for file server and remote terminal/console (optional).

Table A-1

Cables

93-ohm Coaxial Cables

| TYPE | MFR | UL STYLE | NOTES |
|---------|----------------------------|----------|--|
| RG62A U | Belden 9269 Alpha 9062A | 1478 | general indoor use |
| RG62A U | Belden 9268 Alpha 9805 | 1478 | general outdoor use |
| RG62A/U | Belden 89269 Alpha 9162 | --- | plenum use (teflon jacket) |
| | Belden 9393 Alpha 9806 | 1354 | miniature cable requires special connectors |
| RG62B/U | Belden 8255 | 1354 | stranded center conductor (for soldered connectors) |



Appendix B

Propagation Delays

When laying out your network, calculate the propagation time and cable lengths between the workstations most distant from each other (in terms of cable lengths and intervening HUBs).

Maximum allowed propagation time between any two stations is 31 microseconds.

To calculate propagation time:

$$\begin{aligned} \text{Prop. time} &= \text{total length of tp cable (ft)} \times .0013 \\ &+ \text{total length of coax (ft)} \times .00121 \\ &+ \text{total length of optic cable (ft)} \times .00154 \\ &+ \# \text{ of coax/tp HUBs} \times .3 \\ &+ \# \text{ of fiber optic HUBs}^* \times .5 \end{aligned}$$

A HUB connecting a fiber optic cable at one port and a coax or twisted pair cable at another port is counted as a fiber optic HUB.

Maximum allowed cable

| | Coax | Twisted Pair | Fiber Optic |
|---|---------|--------------|-------------|
| Between Stations & HUB | 2,000' | 1,650' | 4,000' |
| Between stations (with intervening HUBs) | 22,000' | 20,000' | 17,000' |

Table E-1
Calculation of Propagation Delay

| From Stn | To Stn | Total Coax (feet) ($\times .00121$) | Total TP (feet) ($\times .003$) | Total Fiber (feet) ($\times .00154$) | Coax/TP HUBs ($\times .3$) | Fiber Optic HUBs ($\times .5$) | Total Propagation Time |
|----------|--------|---------------------------------------|-----------------------------------|--|------------------------------|----------------------------------|------------------------|
| — | — | — | — | — | — | — | — |
| | | + | + | + | + | + | = |
| — | — | — | — | — | — | — | — |
| | | + | + | + | + | + | = |
| — | — | — | — | — | — | — | — |
| | | + | + | + | + | + | = |
| — | — | — | — | — | — | — | — |
| | | + | + | + | + | + | = |
| — | — | — | — | — | — | — | — |
| | | + | + | + | + | + | = |

INDEX

A

active HUB 1-2, 1-3, 2-1, 2-5, 2-6, A-1

B

bibliography BB-1
BNC connector 1-3

C

cabinets

file server 1-1, 1-2, A-1
storage 1-2, A-2

cable

coaxial 1-1, 1-3, 2-9, 2-11, A-1
connectors 1-3
fiber optic 1-3, 2-9, 2-10, A-1
IBM Cabling System 1-3, 2-1, 2-3, A-1
lengths, external 2-9, 2-12, 2-13
placement, external 2-8
type A-3

cabling, IBM Cabling System 1-1, 2-1, 2-3, A-1

calculation, propagation delays B-1

cartridge tape drive 1-2

ceilings, cabling in 2-10

clock/calendar device A-2

coaxial cable, see cable

codes, fire 2-10

connectors

BNC (circular twist lock) 1-3
SMA (circular twist type) 1-3

console A-2

contents v

cooling fans A-2

CPU card A-1

INDEX

D

- definitions 1-2, 1-3
- disclaimer ii
- disk/tape controller 1-3, A-2

F

- fans B-2
- fiber optic cable, see cable
- file server 1-1, 1-2, 2-14
 - cabinet 1-2, A-1
 - configuration 2-15
 - definition 1-2
 - placement 2-14
 - program version iii
- fire code 2-10
- floors, cabling on 2-10

G

- general principles 1-1

H

- hardware components A-1, A-2
- HUB (line isolation device, or LID) 1-2, 2-1, A-2
 - active 1-2, 1-3, 2-1, 2-5, 2-6, A-2
 - definition 1-2
 - external 2-3, 2-6, A-2
 - multiple 2-4, 2-6
 - passive 1-2, 1-3, 2-1, 2-5, 2-6, A-2
 - placement 2-6, 2-7
- humidity requirements 2-6, 2-14

I

IBM Cabling System 2-1
installation 1-2
interconnection rules 2-9, 2-10

L

lengths, cable 2-9 thru 2-13
Line Isolation Device (LID), see HUB

M

modem 2-14, A-2
multiple HUBs 2-4, 2-6, 2-7

N

network interface card (NIC) 1-3, A-2
network topology 2-1
NIC, see network interface card
node 1-2, 2-1 thru 2-3

P

passive HUB 1-2, 2-1, 2-5, 2-6, A-2
passive HUB placement 2-6
peripheral interface card (PIC) 1-3, A-2
physical layout 2-1, 2-2
PIC, see peripheral interface card
placement of
 cable 2-9 thru 2-11
 HUBs 2-6, 2-7
 servers 2-14
power supplies A-2
Print Server Feature Card 1-1, 1-3, 2-1, 2-9, 2-15, A-2
 definition 1-3

INDEX

propagation time 2-9, B-1

R

RAYCOM fiber optic cable 1-3

rules for interconnection of cables 2-9 thru 2-11

S

server 1-1, 2-14, A-2

 definition 1-2

sockets, wall 2-11, 2-12

storage cabinet 1-2, A-2

T

tape drive A-1

temperature requirements 2-6, 2-14

topology 2-1, 2-2

troubleshooting 2-7

twisted-pair cable, see IBM Cabling System

V

version number, file server program iii

W

wall, cabling in 2-11

wall sockets 2-11

workstations A-1

PLAN SERIES PUBLICATIONS

| | |
|---|-----------|
| Cardchk Utility Program for the Apple // | LC40-0402 |
| Cardchk Utility Program for the Apple /// | LC40-0403 |
| Cardchk Utility Program and IBM NIC Theory of Operations Manual for the IBM PC | LC40-0404 |
| File Server Apple User's Guides: | |
| Apple // Pascal | SC40-0501 |
| Apple // DOS | SC50-0502 |
| Apple // CP/M | SC50-0503 |
| Apple /// SOS | SC50-0504 |
| Apple /// CP/M | SC50-0508 |
| File Server Installation and Operation Manual | SC40-0300 |
| File Transfer Server Installation and Operation Manual | SC40-0303 |
| General Index | GA40-0103 |
| General Information Manual | GA40-0100 |
| IBM Personal Computer DOS Reference Manual | SC40-0507 |
| IBM Personal Computer NCI p-System Reference Manual | SC40-0509 |
| Messenger Installation and Operation Manual | SH40-0304 |
| Messenger User's Manual | SH40-0204 |
| Network Command Reference Manual | SC40-0200 |
| Network Installation Manual | GA40-0104 |

BIBLIOGRAPHY

| | |
|--|-----------|
| Physical Planning Manual | GA40-0101 |
| PLAN 3000 Quick Installation Guide | GA40-0107 |
| PLAN 4000 Quick Installation Guide | GA40-0108 |
| PLAN 5000 Quick Installation Guide | GA40-0109 |
| Print Server on the Apple // Installation and Operation Manual | SC40-0301 |
| Print Server on the IBM PC Installation and Operation Manual | SC40-0302 |
| Print Server User's Manual | SC40-0201 |
| Service Manual | LA40-0400 |
| SNA 3270 Emulator User's Manual | SH40-0206 |
| SNA Gateway Installation and Operation Manual | SH40-0306 |
| Technical Notes | SC40-0100 |
| 3270 BSC Emulator User's Manual | SH40-0205 |
| 3270 BSC Installation and Operation Manual | SH40-0305 |
| Using the Network: an Introduction for IBM PC DOS Users | SC40-0510 |

PLANPak Reference Manuals

| | |
|--|-----------|
| DATASTORE LAN User's Manual | SH40-0209 |
| LAN MAIL MONITOR User's Manual | SH40-0212 |
| SuperCalc3 User's Guide and Reference Manual | SH40-0207 |
| SuperWriter User's Manual | SH40-0208 |



Reader Comment Form

This manual is one in a series that describes the use of the PLAN Series systems.

You are encouraged to use this form to communicate to Nestar any problems or suggestions associated with the system. We would like your comments on improving the system itself, as well as on this documentation. Possible topics for comment are: clarity, accuracy, completeness, organization, coding, retrieval, and legibility.

No postage stamp is necessary if mailed within the U.S.A.

Nestar installation location:

Submitter's name:

Address:

Description of problem or suggestion:

Please mail this form to: Nestar Systems, Incorporated
2585 E. Bayshore Road
Palo Alto, California 94303
Attn: PUBLICATIONS DEPT.



No Postage
Necessary
If Mailed
In The
United States

BUSINESS REPLY CARD

First Class

Permit No. 338

Palo Alto, CA

POSTAGE WILL BE PAID BY ADDRESSEE



NESTAR SYSTEMS
INCORPORATED

2585 East Bayshore Road
Palo Alto, California 94303

Fold here

Tape

Please do not staple

Tape