

Burroughs 205

ELECTRONIC DATA PROCESSING SYSTEMS

HANDBOOK

MAGNETIC TAPE SYSTEM
Model 543 Tape Control Unit
Model 544 DataReader

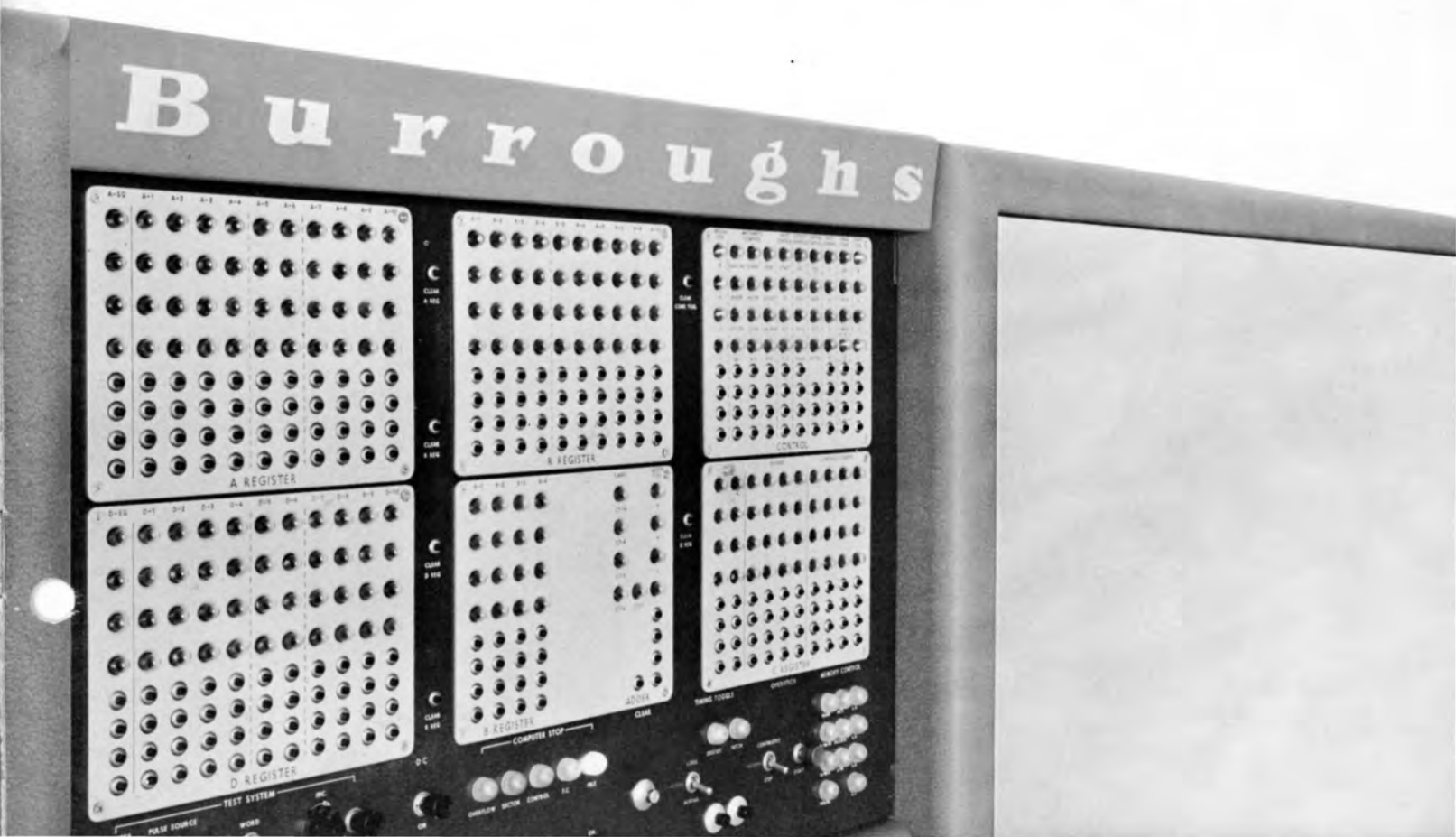

TABLE OF CONTENTS

DATATRON MAGNETIC TAPE SYSTEM

General 1
Model 544 DataReader Magnetic Tape Storage 1

OPERATING CHARACTERISTICS OF THE DATAREADER

How Information is Recorded on the Tape 1
How the Tape Moves in the DataReader 3
How Block Addresses are Recorded 4

DATAREADER COMMANDS

Magnetic Tape Search 4
Magnetic Tape Write 6
Magnetic Tape Read 9
Magnetic Tape Rewind 12
B Register Modification 14

MANUAL CONTROL OF THE MAGNETIC TAPE SYSTEM

DataReader Controls and Switches 15
Manual Operating Features of the Tape Control Unit 18
Calibration Operating Procedure 19

APPLICATIONS

Timing 22
Application Examples 25

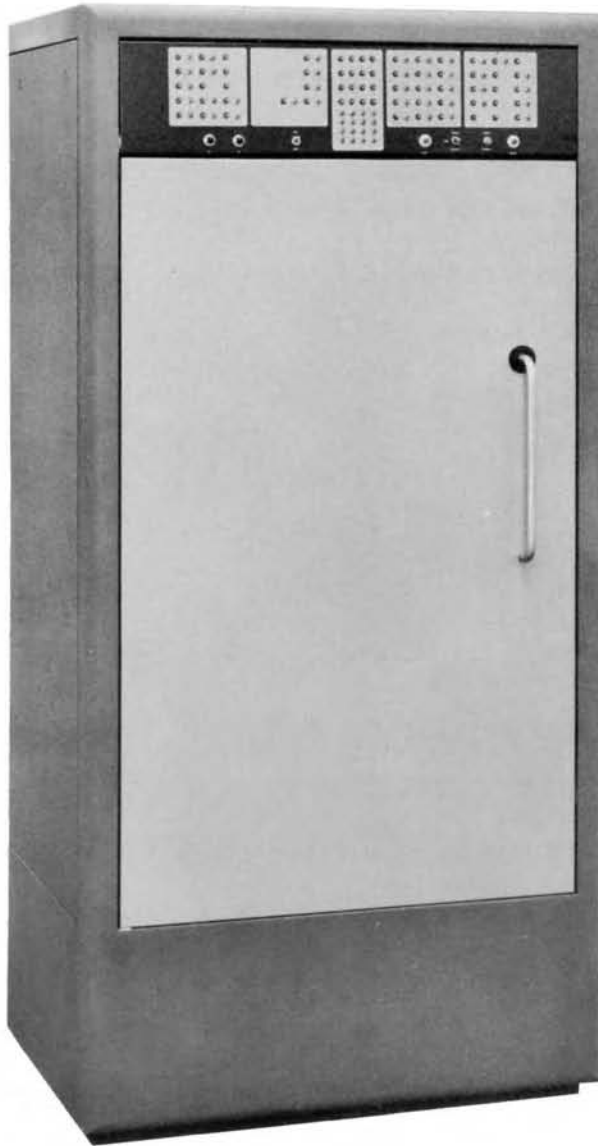

**Model 543 Magnetic
Tape Control Unit**

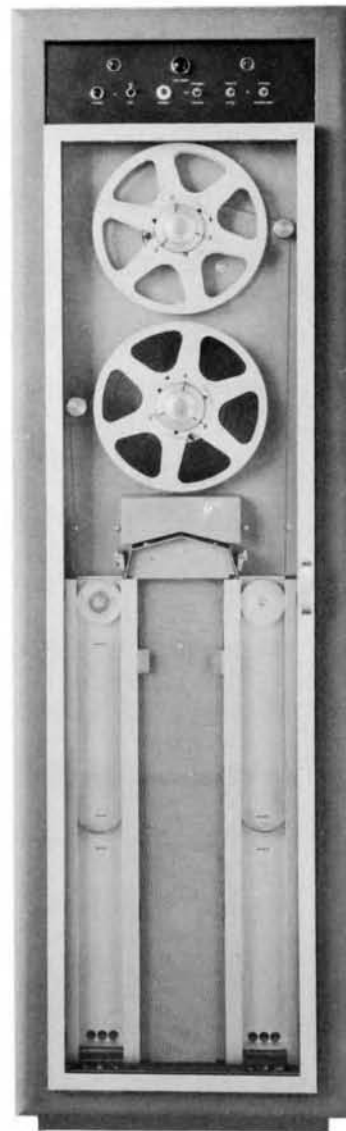

**Model 544 DataReader
Magnetic Tape Storage**

DATATRON MAGNETIC TAPE SYSTEM

GENERAL

Magnetic tape storage is used to store all types of records for processing, such as payroll records, parts records for inventory control, master bills of material, parts explosion sequences, customer records, vendor records. On the DATATRON, magnetic tape storage consists of as many as ten Model 544 DataReader tape transport units, each with a capacity of 400,000 words, and a Model 543 Magnetic Tape Control Unit which provides power and controls the DataReaders via commands from the DATATRON computer.

MODEL 544 DATAREADER MAGNETIC TAPE STORAGE

The DataReader is a reel type magnetic tape storage device. Features which facilitate rapid and reliable processing of large masses of data include:

1. Arrangement of information in blocks of twenty words, each block having a permanently recorded four-digit address.
2. Independent search for any particular block address so that internal processing of data may go on while the search is in progress.
3. Ability to search in both directions, scanning the address immediately on receipt of the search command and automatically moving in the proper direction to find the block.
4. Ability to search for and read only desired information and after processing to return information to the proper position on the same tape from which it was read.
5. Ability to transfer a selectable number of blocks from tape to drum or from drum to tape.
6. Exceptional reliability due to automatic inspection of new tapes, and the automatic checking of recorded information.

OPERATING CHARACTERISTICS OF THE DATAREADER

HOW INFORMATION IS RECORDED ON THE TAPE

The DataReader uses a plastic base tape 3/4" wide and 2500 feet long. The tape is wound on a reel 10½" in diameter.

Twelve channels are recorded across the width of the tape. Of the twelve, only six are read or recorded at one time. The six channels are called a "lane". The six channels of one lane are interlaced with those of the other lane as shown in Figure 1. Each of the two lanes has its own read-write head. The heads are designated as odd or even and are selected by the program SEARCH command.

Of the six channels, four contain decimal digits in the same 1-2-4-8 binary code as used on the DATATRON drum. The fifth channel is used for a parity check bit. The sixth channel is used for a block marker which signals the four digit block address. The digits of the address occupy the same information channels used for the decimal digits of stored data. Block markers and addresses are recorded twenty words apart. Addresses are permanently recorded in the sequence 0000 through 9999. A full tape contains 10,000 blocks in each lane, 20,000 blocks per full reel.

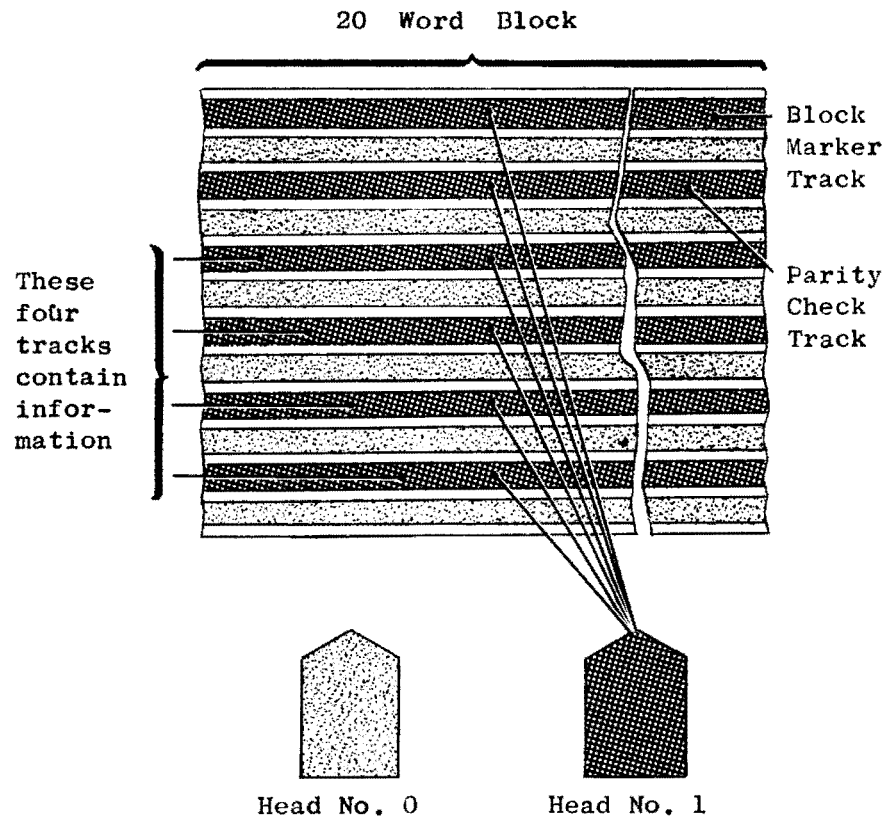

Figure 1. Tape detail.

Digits are recorded on tape with a density of 100 per inch per lane. Each linear inch of tape contains 200 digits. A block of information occupies 2.4 inches in one lane. The blank space between blocks is 0.3 inch and the block address is 0.08 inch for a total of 2.78 inches of tape per block.

The tape moves at 60 inches per second while searching, reading or writing. The time for these operations is 46 milliseconds per block. Start time for the electro-mechanical components of the DataReader is 6 milliseconds.

HOW THE TAPE MOVES IN THE DATAREADER

Each DataReader contains the mechanical elements necessary to move the tape, and the magnetic heads which perform the reading and writing functions. During use, the DataReader operates a feed and a take-up reel. Movement of the reels is independent of tape movement past the heads and is controlled only by the position of the tape loops in the two vacuum columns. (See Figure II.)

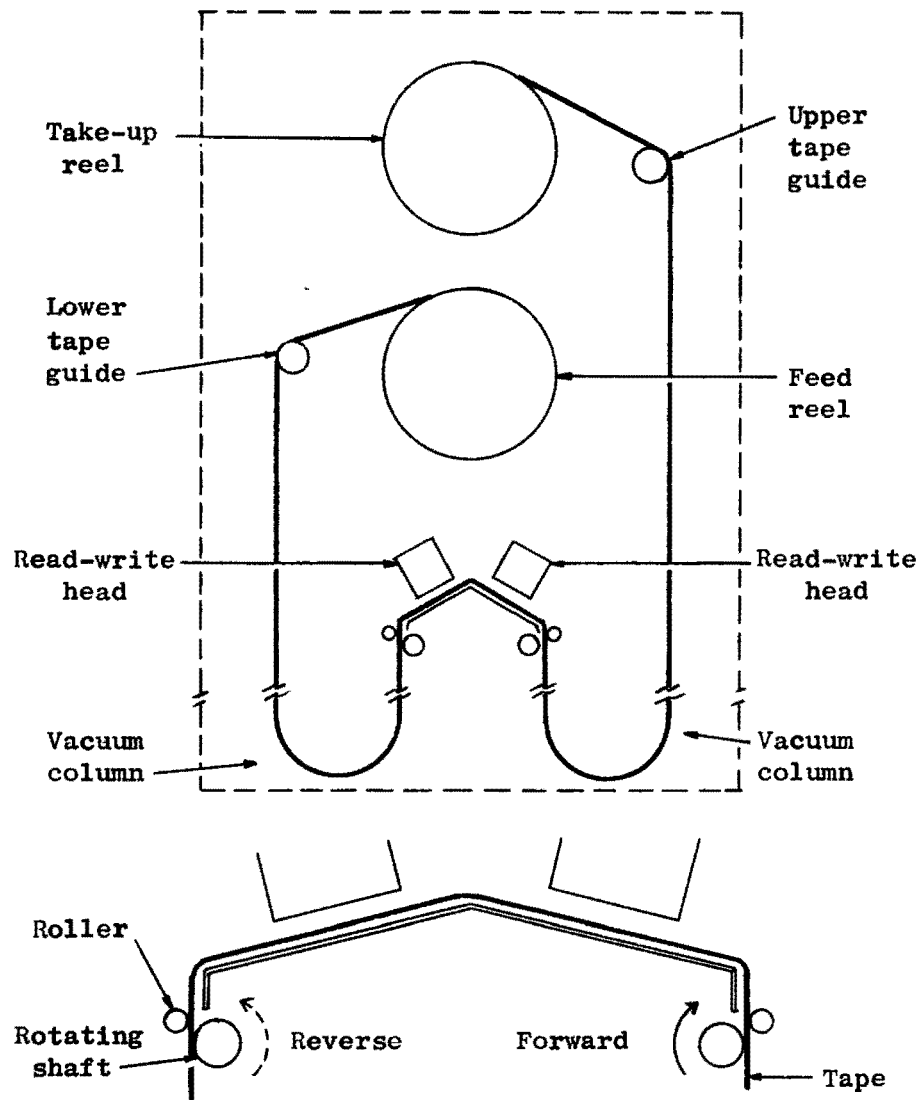

Figure II. Tape movement.

The use of vacuum columns provides several feet of slack tape ready for immediate movement without waiting for the reels to start their independent motion.

The tape is moved forward by command under a read-write head as follows: The right-hand roller pivots to provide friction between the tape and a constantly rotating shaft causing the tape to move in the forward direction. Reverse movement is caused by the left-hand roller pivoting against the left-hand shaft.

Vacuum switches in the upper and lower tape guides sense the beginning or the ending of a tape. Perforations at the ends of the tape release the seal at one of the tape guides, activating the switch that stops all tape movement. Unperforated tape automatically seals the vacuum switches, allowing normal tape movement.

HOW BLOCK ADDRESSES ARE RECORDED

Calibration is the process of recording block markers and addresses on magnetic tape at twenty-word intervals. It must be done before information can be recorded on the tape by the computer. A DataReader and the Tape Control Unit are used for calibration.

Calibration is done in two steps. The first is a process of running the tape forward the entire length, recording a constant magnetic level. The second step is to examine the magnetic level during reverse movement to determine whether any tape imperfections exist. As the tape begins its reverse movement, the area is examined and if it is perfect, a block marker and address are placed at every tape length equal to twenty words. Addresses are automatically counted down from 9999 through 0000 and recorded as block markers are recorded. If an imperfection is detected, the inspection starts over from the point of imperfection. Thus, a perfect recording area is assured.

Spliced and worn tapes may be recalibrated and any area not acceptable for recording will automatically be omitted during calibration.

Calibration is performed twice for each tape, once for each lane of six channels on the tape.

DATAREADER COMMANDS

MAGNETIC TAPE SEARCH (MTS)

Unlike a magnetic drum, which rotates continuously, magnetic tape moves only on command from the DATATRON. Any desired block

may be located by means of a SEARCH command. The SEARCH command takes the form:

```
s Ohup 42 xxxxx  
  
s Sign position (See section on B Register  
modification.)  
  
O of no significance in this command  
  
h digit which indicates read-write head to  
be used; 0, 2, 4, 6, 8 for even head;  
1, 3, 5, 7, 9 for odd head  
  
u DataReader unit number, 1, 2...8, 9, 0  
  
p breakpoint code position (See Central  
Computer Handbook)  
  
42 numerical code for MAGNETIC TAPE SEARCH  
  
xxxx address of the desired block
```

For example, 0 0120 42 1000 is the command to search for block 1000 under the odd read-write head on DataReader 2.

As the tape moves, each block address read from tape is compared with the address in the "T" Register. The tape stops on an equal comparison, ready for a read or write operation. If the first address read is numerically greater than the one desired a reverse search is automatic.

The time required to complete a SEARCH operation depends upon the tape distance from the information block at the read-write head to the desired block. Each block is searched in 46 milliseconds.

Only one DataReader may be searching at a time. If a second SEARCH command is given before one search is completed, the overflow in the DATATRON is turned on. The programmer may provide for this by placing a conditional change of control command, CC, (see Central Computer Handbook) after a SEARCH command.

Program Example

7000	0 0130	42	MTS	1250
7001	0 0140	42	MTS	4050
7002	0 0000	28	CC	7001

When command 7000 is ready to be executed, DataReader 3 begins searching for block 1250 on the odd head. Command 7001 turns on the overflow, if DataReader 3 is still searching. Since the overflow is on, command 7002 cycles the operation back to the preceding command or to another address as specified by the command. When the search for block 1250 on DataReader 3 is completed, command 7001 no

longer turns on the overflow and DataReader 4 begins searching for block 4050. Command 7002 is ignored. Command 7003, if not a tape command, can proceed while DataReader 4 is searching.

MATNETIC TAPE WRITE (MTW)

Magnetic Tape Write is the operation of transferring information from the computer to magnetic tape. Before a WRITE command is executed, the desired block of information must be in position under the read-write head. This positioning is the result of a SEARCH command given previously, or the result of a previous reading or writing operation. After any READ or WRITE command, the tape is in position to read or write the block following the last one read or written.

The WRITE command takes the form

	s	nnup	50	xxxx
s		sign position	(See section on B Register modification)	
nn		the number of blocks to be written,	01 through 00 (100)	
u		DataReader unit number,	1, 2...8, 9, 0	
p		breakpoint code position	(See Central Computer Handbook)	
50		numerical code for	MAGNETIC TAPE WRITE	
xxxx		address in main storage from which first word in first block is to be transferred		

For example, 0 0420 50 1060 is the command to write four consecutive blocks of twenty words each on DataReader 2, transferring words from consecutive storage cells on the drum beginning with 1060.

There is no need to specify the odd or even head in a WRITE command, since the head selected by a SEARCH command will remain in position to be used until the other head is selected by a succeeding SEARCH command. One WRITE command can transfer as many as 100 blocks to magnetic tape from the DATATRON drum. The indication for 100 in the nn positions of the command word is 00.

When a WRITE command calls for more than one block, successive blocks of information from DATATRON main storage go alternately through the 5000 and 4000 quick access loops to magnetic tape. While one of these two loops is being unloaded to magnetic tape, the other is being loaded from main storage.

The system is designed to write the last block from the 4000 loop. For an even number of blocks, the 5000 loop is used first; for an odd number of blocks, the 4000 loop is used first. A WRITE operation calling for one block and containing a main storage address writes on tape from the 4000 loop only. The 5000 loop is not affected.

For writing on tape from main storage, it is recommended that the address of the first cell to transfer information be divisible by 20.

Program Example

7000 0 0530 50 2000

When this command is executed, the twenty words in cells 2000 through 2019 are transferred to the 4000 loop. As the information from the 4000 loop is recorded on DataReader 3, the twenty words in cells 2020 through 2039 are transferred to the 5000 loop. The operation proceeds in this way until the information for the fifth block, from cells 2080 through 2099, has been transferred from the 4000 loop to magnetic tape. After the WRITE command, the 5000 and 4000 loops contain the same information as cells 2060 through 2099.

During the execution of a WRITE command, the transfer from main storage to the 4000 and 5000 loops is inhibited if the command address is 8000 or greater. In the example following, internal data processing is followed by the writing of two blocks on tape.

Program Example

7010 0 0000 02 4019
7011 0 0210 50 8000

All digits recorded on magnetic tape have an extra bit added in the parity check channel if the sum of the digit's bit structure is odd. A change of magnetic flux in the Data-Reader recording system is a zero in the four bit decimal code. The parity channel is recorded to make the sum of the zeros in the five channels (four information channels and one parity channel) an even number. Figure III shows the flux changes for each decimal digit, with the total number of changes for each digit on the bottom row.

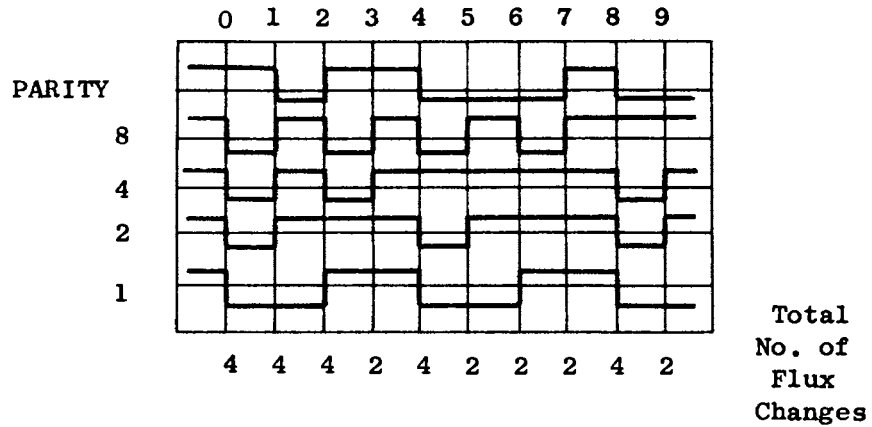

Figure III. Parity recording.

All magnetic tape read operations check automatically to see that the total number of changes in the five channels is even.

If a WRITE command follows a SEARCH command, the search may not be completed by the time the DATATRON is ready to execute the WRITE command. The occurrence of any command affecting magnetic tape while a search is in progress sets up the overflow condition in the DATATRON. The programmer may provide for this by setting up an interrogation of the search, using a conditional change of control. If the search is not completed, the WRITE command will set the overflow, and the next command will change control. On a return to the WRITE command, if the search is completed, the WRITE command is executed, it does not turn on the overflow, and the conditional change of control is ignored.

Program Example

7000	0	0130	MTS	1250
7001	0	0230	MTW	8000
7002	0	0000	CC	7001

Execution of step 7000 starts DataReader 3 searching for block 1250 using the odd read-write head. Since the search will not be completed by the time step 7001 is ready, the overflow is set and the write operation delayed. Execution of step 7002 sends control back to attempt the WRITE command again. The cycling continues until the search is completed. After the search is completed, the information in loop 5000 is written to block 1250 using the odd head of DataReader 3. Then the 4000 loop is written to block 1251 of the same tape. Since the overflow is not on, the next instruction to be executed is 7003.

As a protection against writing on any particular tape, the NOT WRITE switch on the DataReader may be turned on. Any write command referring to this particular DataReader will cause the tape to move, but no writing will occur. This provides constant protection for any tape file which is not to be altered.

Figure IV shows the information path during tape write. The tape write operation destroys the previous contents of the A Register and leaves the sign and ten digits of the A Register containing the last word written to tape.

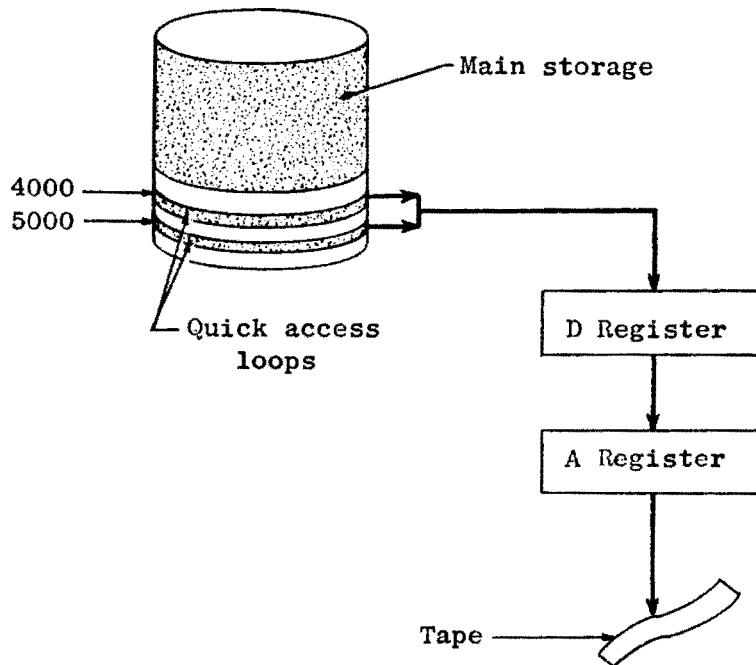

Figure IV. Information path during magnetic tape WRITE

MAGNETIC TAPE READ (MTR)

Magnetic Tape Read is the operation of transferring information from the magnetic tape to the DATATRON drum. Before a READ command is executed, the desired block of information must be in position under the read-write head. This positioning is the result of a SEARCH command given previously, or the result of a previous reading or writing operation. After any READ or WRITE command the tape is in position to read or write the block following the last one read or written.

The READ command takes the form:

	s	nnup	40	xxxx
s		sign position (See Section on B register modification)		
nn		the number of blocks to be written, 01 through 00 (100)		
u		DataReader unit number, 1, 2...8, 9, 0		
p		breakpoint code position (See Central Computer Handbook)		
40		numerical code for MAGNETIC TAPE READ		
xxxx		address in main storage to which first word in first block is to be transferred		

For example, 0 0740 40 3000 is the command to read seven consecutive blocks of twenty words each from DataReader 4, transferring words to consecutive storage cells on the DATATRON drum beginning with 3000.

There is no need to specify the odd or even head in a READ command, since the head selected by a SEARCH command will remain in position to be used until the other head is selected by a succeeding SEARCH command. One READ command can transfer as many as 100 blocks to the DATATRON drum. The indication for 100 in the nn positions of the command word is 00.

When a READ command calls for more than one block, successive blocks of information from tape pass alternately through the 5000 and 4000 quick access loops to main storage. While one of these two loops is being transferred into main storage, the other is being filled from tape.

The system is designed to read the last block through the 4000 loop. For an even number of blocks to be read, the 5000 loop is used first; for an odd number of blocks, the 4000 loop is used first. A read operation calling for one block goes through the 4000 loop only. The contents of the 5000 loop are not affected.

For reading to main storage it is recommended that the address of the first cell to receive information be divisible by 20.

Program Example

7000 0 0530 40 2000

When this command is executed, DataReader 3 begins reading into the 4000 loop. As the second block is being read into the 5000 loop, the contents of the 4000 loop is transferred to main storage. The operation proceeds in this way until the fifth block has been transferred from the 4000 loop to cells 2080 through 2099. After the READ command, the 5000 and 4000 loops contain the same information as the last two blocks read from tape.

During the execution of a READ command, the transfer from the 4000 and 5000 loops to main storage is inhibited if the command address is 8000 or greater. In the example following, two blocks are read in and processing is begun in the loops.

Program Example

7000 0 0210 40 8000
7001 0 0000 64 5000
 etc.

During any read operation, the four information channels and the parity channel are checked for even number of zero bits, or magnetic flux changes, in the five channels. If the number of changes is discovered to be odd, an alarm bell rings and the tape system automatically tries to read the information again. If the error persists for a preset number of attempts, the computer stops for manual intervention.

If a READ command follows a SEARCH command, the search may not be completed by the time the DATATRON is ready to execute the READ command. The occurrence of any command affecting magnetic tape while a search is in progress sets up the overflow condition in the DATATRON. The programmer may provide for this by setting up an interrogation of the search, using a conditional change of control. If the search is not completed, the READ command will set the overflow, and the next command will change control. On a return to the READ command, if the search is completed, the READ command is executed, it does not turn on the overflow, and the conditional change of control is ignored.

Program Example:

7000	0	0110	42	MTS	1250
7001	0	0210	40	MTR	8000
7002	0	0000	28	CC	7001

Figure V shows the information path during tape read. The tape read operation destroys the previous contents of the A register and usually leaves the sign and ten digits of the A register containing zeros.

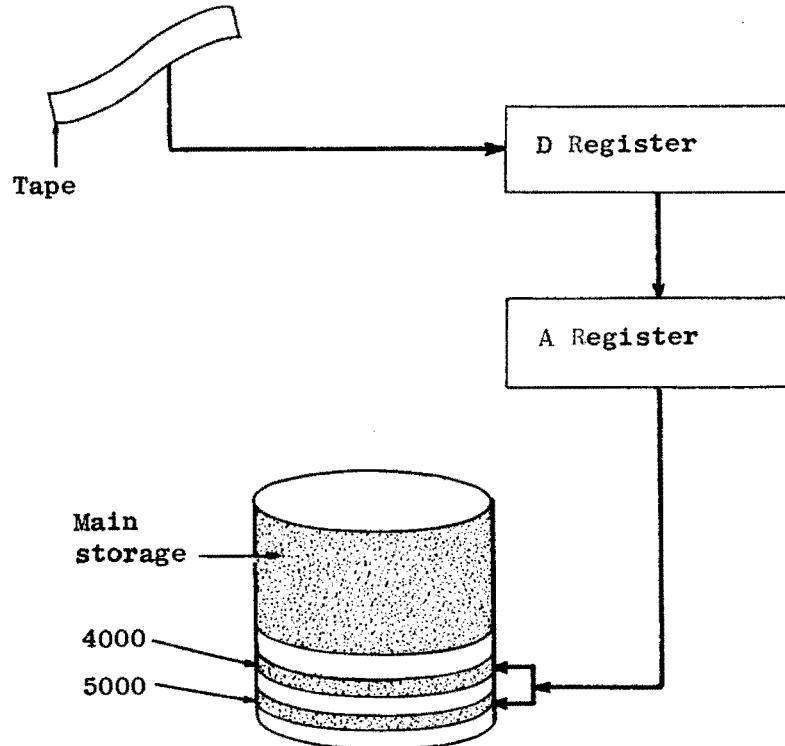

Figure V. Information path during magnetic tape READ.

MAGNETIC TAPE REWIND (MTRW)

The rewind instruction releases the tape from the read-write heads and runs the tape backward to the beginning at high speed. About three and one-half minutes are required to rewind a full tape. Once started, rewind is controlled by the DataReader itself; therefore, more than one rewind may be in progress at the same time and any DataReaders not rewinding may be used for other tape operations. If the DataReader being rewound is called for, the overflow in the DATATRON will be turned on.

The REWIND command takes the form

s	OOup 52 xxxx
s	not used by the command
OO	not used by the command
u	the DataReader unit number
p	the breakpoint position (see Central Computer Handbook)
xxxx	not used by the command

For example, the command 0 0010 52 0000 would rewind DataReader 1.

The NORMAL/REWIND READY switch on the control panel of the DataReaders determines the status of the tape unit after a rewind. If this switch is set to NORMAL, any command to the unit after a rewind will turn on the overflow in the DATATRON. If the switch is set to REWIND READY a SEARCH, READ or WRITE command may be executed after the DataReader has completed the REWIND.

Program Example

7000	0	0010	MTRW	0000
7001	0	0020	MTRW	0000
7002	0	0030	MTS	2000
			:	
	0	0010	MTS	0010
	0	0000	CC	

Step 7000 will start DataReader 1 rewinding. Step 7001 will start DataReader 2 rewinding. Both of these units will be in motion as DataReader 3 begins a search for block 2000 using the even head.

Assuming that no other tape commands have been given between step 7002 and the next search command, (a number of program steps away), the search for block 0010 on DataReader 1 might cause the overflow to be set for any one of the following reasons:

1. Rewind has not been completed on DataReader 1.
2. The search has not been completed on DataReader 3.
3. The rewind on unit 1 has been completed, but the NORMAL/REWIND READY switch is set to NORMAL.

B REGISTER MODIFICATION

Modification During Execution

All magnetic tape commands may be modified by the B Register as the command is brought into the C Register from the DATATRON drum. The B Register is added to the address digits of any command with a 1 in the sign position.

Examples

MAGNETIC TAPE SEARCH (MTS) The contents of the B Register will be added to the address to be located specified by the command:

	<u>COMMAND</u>	<u>B REGISTER</u>
1	0130 MTS 1000	0100

On execution of the command, the contents of the B Register (0100) will be added to the address (1000) and a search for block 1100 will be initiated, using DataReader 3 and its odd read-write head.

MAGNETIC TAPE READ (MTR) The contents of the B Register is added to the beginning address to which the first block of information is to be read.

	<u>COMMAND</u>	<u>B REGISTER</u>
1	0230 MTR 1000	0100

On execution of the command, the information from DataReader 3, using the head last selected by a search command, will be read and placed in memory cells 1100 to 1119 for the first block and 1120 to 1139 for the second block.

MAGNETIC TAPE WRITE (MTW) The contents of the B Register is added to the starting address specified by the write command.

	<u>COMMAND</u>	<u>B REGISTER</u>
1	0130 MTW 1000	0100

On execution, the writing starts on DataReader 3, writing one block on the head last selected for the unit beginning at address 1100.

Modification During Input

Program instructions may be stored on magnetic tape as well as data. To be executed, the instructions must be brought into the DATATRON drum. During passage from the tape to the

drum via a MAGNETIC TAPE READ command, the instruction address may be modified by the B Register. Modification will occur on any instruction with a 2 or 3 in the sign position, provided the B MODIFICATION switch on the Tape Control Unit is set to NORMAL. If modified, the instruction will appear on the drum with a 0 or a 1 in the sign column. For example, if the B Register is set to 0100, the command 2 0000 64 2000 read from tape would be stored on the drum as 0 0000 64 2100. If the B MODIFICATION switch is set to B SUPPRESS, no modification will occur and the instructions will appear on the drum with the original 2 or 3 in the sign position. This provision makes it possible to read data from the tape with 2's, 3's, 4's, 5's, 6's, and 7's, but not 8's or 9's, in the sign position.

MANUAL CONTROL OF THE MAGNETIC TAPE SYSTEM

DATAREADER CONTROLS AND SWITCHES:

Control Lights

- a. POWER, ON if DataReader and Tape Control Unit power is on.
- b. DESIGNATED: ON if the unit was selected by an executed command.
- c. NOT WRITE: ON if the switch under the control panel is ON.
- d. NOT READY: ON if any one of the following conditions is present:

- Power Failed
- Tape broken
- Tape run off the reel
- Vacuum system failed
- Main door not closed
- Unit set for local control
- Rewind proceeding

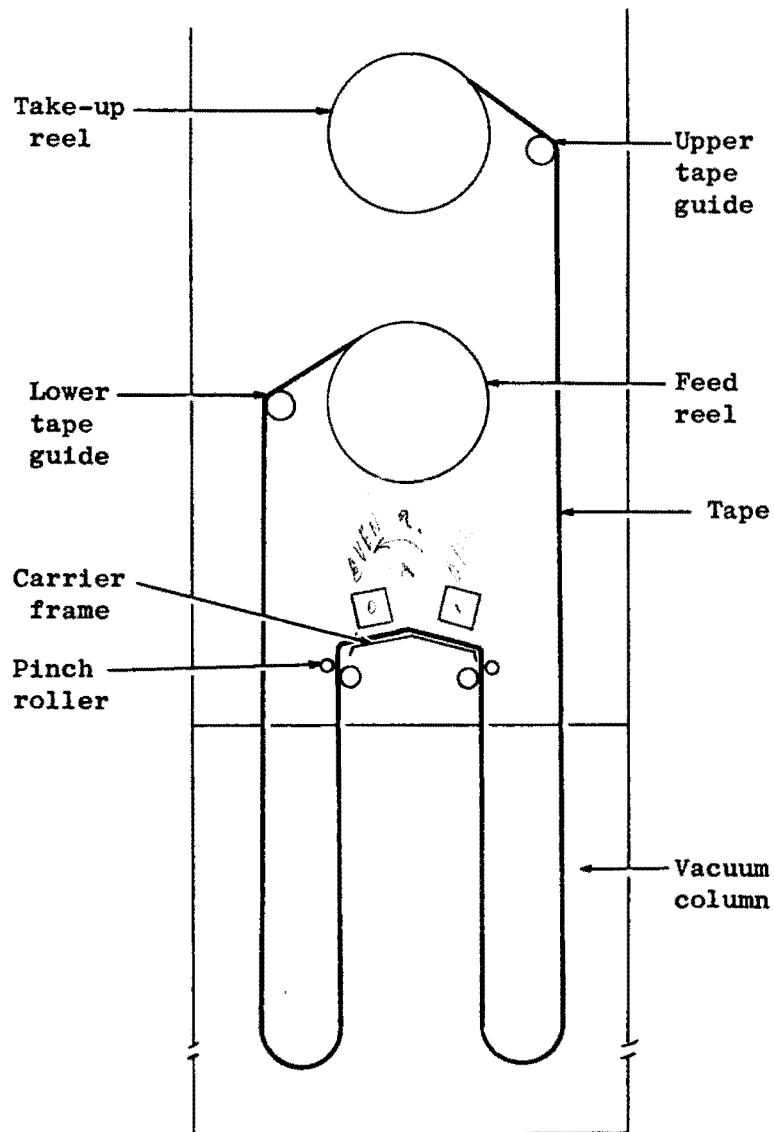
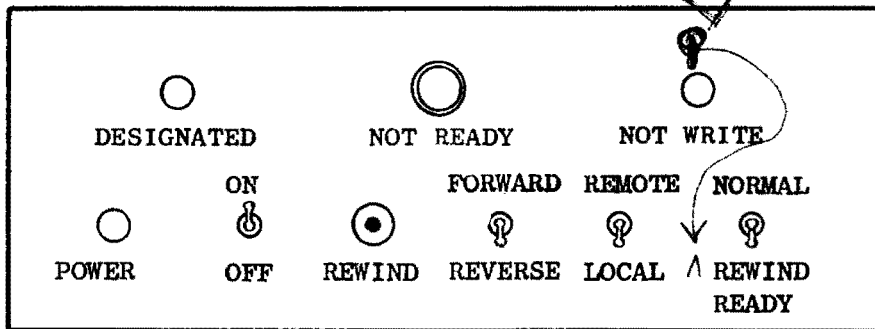

Figure VI. DataReader operation.

Local Control Switches

Setting the REMOTE LOCAL switch to LOCAL will cause the following switches to be operative:

- a. FORWARD REVERSE: Setting this switch in FORWARD position will cause the tape to move in a forward direction until the switch is reset or the end of the tape is reached. Setting it in the REVERSE position moves the tape in a backward direction until the switch is reset or the end of the tape is reached.
- b. REWIND button: Depressing this button will cause a rewind to the beginning of the tape.

Remote Control Switches

Setting the REMOTE LOCAL switch to REMOTE will allow the DataReader to be operated by programmed commands or manually from the Tape Control Unit. The following switches pertain to remote operations:

- a. NORMAL REWIND READY: When set to REWIND READY, it allows the tape unit to be addressed again by a SEARCH command after the rewind is complete without manual intervention.
- b. NOT WRITE: When set to ON, prevents writing on the tape from any computer instruction.

Loading the DataReader

Place the empty take-up reel on the upper tape reel hub and the feed tape on the lower hub. The tape feeds counterclockwise off the top of the reel with the shiny side of the tape up.

Open the vacuum column doors and unroll the tape as necessary to:

- a. Feed over the lower tape guide.
- b. Feed under the tape guide roller in the left vacuum column leaving a hanging loop.
- c. Feed the tape between the pinch rollers and over the carrier frame as indicated in Figure VI.
- d. Leave a loop of tape hanging in the right vacuum column.
- e. Feed the end of the tape up and over the upper tape guide and into the slot in the center of the take-up reel to attach; then turn the take-up reel two revolutions to secure the tape.

Adjust the tape to the amount of slack shown in the diagram and close the vacuum column doors and the main door.

MANUAL OPERATING FEATURES OF THE TAPE CONTROL UNIT

Manual Control of the Tape Control Unit:

Ordinarily the Tape Control Unit is manually controlled only for independent operations such as CALIBRATION. The main control panel is made up of five smaller panels. (See Figure VII). The panel at the left is for maintenance engineering and is not set by the operator.

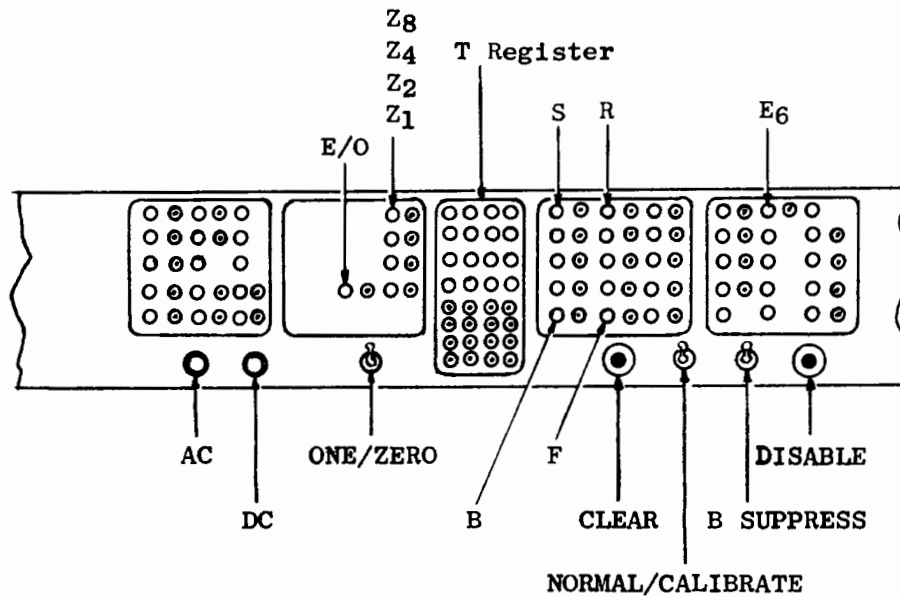

Figure VII. Control panel of Tape Control Unit.

The second panel from the left contains the switches and indicators to select a DataReader and its odd or even head. If the odd head is selected, the E/O indicator digit is on. The unit is indicated by adding the indicators lighted in the four vertical indicators prefixed by Z. Any indicator may be turned off by positioning the ONE/ZERO switch to ZERO and then depressing the same button.

The third panel displays the content of the T Register in binary-coded decimal arrangement. The amount in the T Register may be modified by the use of the buttons located below the indicators. These switches are depressed vertically in the 8-4-2-1 manner. Depressing the lowest button under G will set 1000 into the T Register, if none of the indicators are on. By depressing the next higher button in G after depressing the lowest, the T Register will contain 3000.

The fourth panel from the left contains indicators chiefly used for maintenance. However, some are used by the operator for the CALIBRATION function and these are explained. The top lefthand indicator labeled S refers to a tape search instruction if lighted. The lowest indicator in the same column, B, starts the backward movement of the tape unit if lighted. In the middle column, the R at the top indicates a recording operation. F at the bottom of the middle column moves the tape forward if the indicator is lighted. The last column is not indexed by the operator.

In the last panel, the only indicator generally indexed by the operator is the E6 which is turned on if the E/O toggle in the second panel is lighted.

Tape Control Unit Switches and Controls

The signals AC and DC refer to the power input. In use, both signals are on.

The ZERO/ONE switch is a spring loaded switch that is held in the ZERO position and an indicator button depressed at the same time to turn off a lighted indicator.

The CLEAR button turns all the indicators off.

The NORMAL/CALIBRATE switch is in NORMAL for computer functions and in DEAD or CALIBRATE during CALIBRATION, depending on the function being performed.

The NORMAL/SUPPRESS B is set according to the program requirements. If the switch is set to NORMAL, any word with a 2 or a 3 in the sign position will have the contents of the B Register added to its four least significant digits on the way to the DATATRON drum. If the switch is set to SUPPRESS, the sign position of the word is left unchanged and the word is stored without addition of the B Register.

Disable

This switch is depressed to stop all tape movement during a program run. Its main use is to stop erratic tape operation should a search command be given for a non existent block address.

CALIBRATION OPERATING PROCEDURE

Calibration is a two step operation; first, erasing one lane of six channels on the tape as it is run forward, then placing the block markers automatically during rewind to provide a tape address section. This is repeated for the second lane by selecting the alternate head.

To calibrate a tape loaded on a DataReader, set the switches on the DataReader as follows:

1. NOT WRITE switch to OFF
2. FORWARD/REVERSE to OFF
3. REMOTE/LOCAL to REMOTE
4. REWIND READY to NORMAL
5. POWER to ON

At the Tape Control Unit, set the switches as follows:

1. NORMAL/CALIBRATE to DEAD
2. Depress the CLEAR button
3. Set the DataReader unit number into Z₁Z₂Z₄Z₈
4. Set the E/O toggle to 1 if the even head is to erase and calibrate first. Set E₆ to 1 if E/O is 1.
5. Turn S (search) ON then OFF to select the head.
6. Turn B on until the end of the tape is reached, and then turn it off.
7. Turn R (record) and the F (forward) ON and allow the tape to move to the far end. This will erase and record a constant flux level throughout the tape length for one lane.
8. Turn B ON and then OFF after running backwards a few feet.
9. Set the number of blocks desired, plus five, into the T Register.
10. Move the NORMAL/CALIBRATE switch from DEAD to CALIBRATE and allow the tape to run until it stops automatically at the other end. The T Register should then be zero.
11. Repeat for the second lane by selecting the alternate head.

PREPARING AND HANDLING MAGNETIC TAPES

Before a magnetic tape is used, both ends must be perforated for a length of five feet. The new tape may be perforated by using the Flexowriter punch or by splicing a perforated

leader to each end. Splicing is done by placing the tapes end to end and binding with a strong adhesive tape.

Heat and humidity affect recording on magnetic tape. Ordinary room air conditioning may provide the necessary thermal control, but special control may be needed to maintain a recommended humidity of 40% to 60% for the plastic base tape now used in the DataReader.

Magnetic tapes produce the best results when stored under the same conditions as when the recording was done. The tape must be kept free of dust and creases. Special care should be taken to avoid handling any part of the tape on which information has been recorded. New tapes should be left to condition in the computer room several hours before they are used.

APPLICATIONS

APPLICATION TIMING

Usually the programmer is faced with a number of different methods for setting up a problem. His choice of method is based largely on which one will solve the problem in the least amount of time, thus freeing the system for other work. In many cases, a large job must be done within certain time limits. It is then essential that the programmer determine the most efficient method of operation.

One factor in decreasing overall time requirements is the independent search feature of the DATATRON magnetic tape system. As the calculation, input or output from the system is proceeding, the magnetic tape may be searching for the next desired block or blocks of data.

The DataReader tape transport moves the tape past the read-write heads at the rate of 60 inches per second. Each 20-word block of information is 2.78 inches in length (including block marker and inter-block gap); therefore, the time required to pass over a block during the search operation is 46 milliseconds. (2.78 inches/60 inches per second = 46 milliseconds.)

To calculate the time required for a complete search operation, the initial start time must be considered. This time is a maximum of 6 milliseconds. Also, after the correct block has been found, the tape will have overshoot the beginning of that block. Therefore, after every search and before a read or write can be given, the tape must "turn around" in order to position the correct block before the read-write head. The maximum time for turn around is 21 milliseconds. The search for a section of tape ten blocks away would require about 487 milliseconds ($10 \times 46 + 6 + 21$) including start and turn around.

In most problems using tape search operations, the number of blocks covered during each search is not constant. The average time for a search must then be calculated. For example, a tape containing 10,000 blocks of information on the even lane has 20% activity during one pass through the tape. The average time required for each search operation would be calculated as follows:

The activity figure of 20% means that one out of every five blocks will be read, or the average search will skip four blocks. The time required for the average search is therefore $4 \times 46 + 6 + 21 = 211$ milliseconds.

The rate of reading and writing is the same as searching; that is, 60 inches per second, or 46 milliseconds per block, plus start time. Turn around also occurs after reading and writing; however, it is not included in the reading or writing time since computation starts immediately after the last word has been read or written. Turn around time need be considered only if another tape command to that unit is to be given immediately after the reading or writing has been completed.

Examples:

Assume a problem with 10% activity over 10,000 blocks. It is required that two blocks be read for each cycle through the program. Also assume that calculation time (including input and output) is 500 milliseconds per cycle. In this case, 10% activity would be two blocks out of twenty or the search command will, on the average, skip 18 blocks each program cycle. Search time will therefore be $18 \times 46 + 6 + 21 = 855$ milliseconds. Read time will be $2 \times 46 + 6 = 98$ milliseconds. From the diagram below it can be seen that the time required for each cycle will be 953 milliseconds. With 10% activity on the tape, there will be 1000 cycles, for a total problem of time of 953 seconds or approximately 16 minutes.

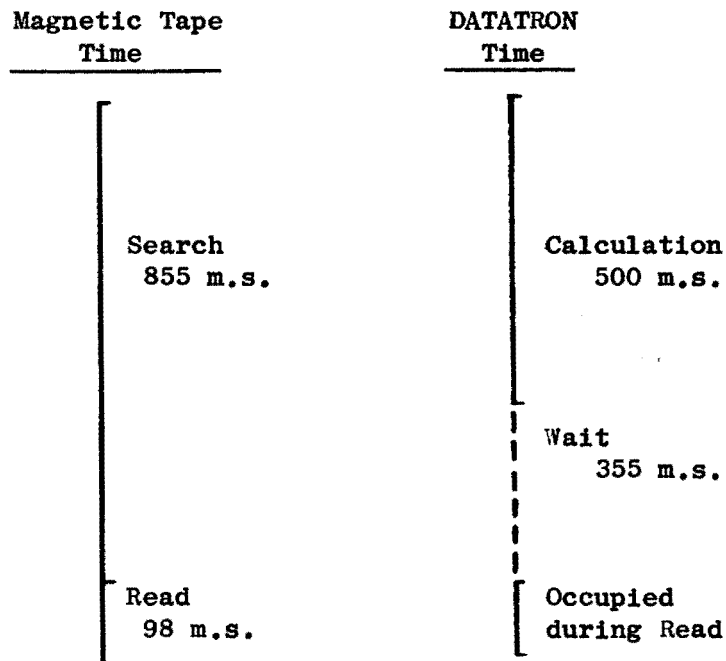

The same problem with 20% activity would use two out of every 10 blocks. Therefore, the search command would, on the average, skip eight blocks. The time required for each search would be $8 \times 46 + 27 = 395$ milliseconds. As shown in the diagram below, the tape unit must wait for calculation to finish in the computer.

<u>Magnetic Tape</u> Time	<u>DATATRON</u> Time
Search 395 m.s.	Calculation 500 m.s.
Wait 105 m.s.	
Read 98 m.s.	Occupied during Read

The total time required for each cycle is $500 + 98 = 598$ m.s. With 20% activity, 2000 cycles are processed. Therefore, the total time for the problem in this case is 1196 seconds. Though the work load has increased 100% the time has increased only 25%.

The two previous examples have used 10,000 blocks of information recorded on only one lane of the tape, under the even head. If both lanes are used, the search time is considerably less. For example, assume that the 10,000 blocks are placed alternately on one lane and then the other. Only 5000 blocks of each lane are used. Taking the first example of 10% activity, two blocks out of 20 are processed. The search command skips 18 blocks, however, the 18 blocks are spread across both lanes and, therefore, lengthwise, the tape must move a space of only nine blocks. Thus, the search time is $9 \times 46 + 27 = 441$ milliseconds, approximately half that when only one lane is used.

Magnetic Tape
Time

DATATRON
Time

Search 441 m.s.	Calculate 500 m.s.
Wait 59 m.s.	
Read 98 m.s.	Occupied during Read

The average time for each cycle using both lanes of the tape is 598 milliseconds and the total problem time is 598 seconds. By using both tape lanes the 355 milli-second wait time is eliminated.

APPLICATION EXAMPLES

Example I

The amount of a customer payment is stored in cell 7015 on the drum. Post it to the customer account contained in block 1000 on DataReader 3, in which the balance is the second word of the block.

Steps

- Search for block 1000 on DataReader 3.
- Read the block to the drum, and protect the READ command with a CC back to the READ.
- Search again for the same block. This search will be performed while the payment is being posted on the drum.
- Subtract the payment from the balance and store the new balance in the cell that held the old one.
- Write the block on magnetic tape in the same location it came from.

Program

7000	0 0030	MTS 1000	Search unit 3 for block 1000
7001	0 0130	MTR 2000	Read block 1000 to 2000 - 2019
7002	0 0000	CC 7001	Delay until search is over
7003	0 0030	MTS 1000	Position block 1000 again
7004	0 0000	CAD 2001	Bring balance to A Register
7005	0 0000	SU 7015	Subtract amount of payment
7006	0 0000	ST 2001	Store new balance in 2001
7007	0 0130	MTW 2000	Write 2000 - 2019 in block 1000
7008	0 0000	CC 7007	Delay until search (7003) is over

Example II

Use the information in a two-word transaction record to update a two-word inventory record on tape for one of 150,000 parts.

The transaction record, stored in cells 5010 and 5011, is in the form:

Part Number	Net Balance Change
5010	5011

The inventory record is in the form:

Balance on Hand	Storage Location	Section
One Word	One Word	

The part number is in the form:

x x x x h r a a a a

xxxx is information not related to the location of the record on tape.

h 0 or 1, designates the read-write head.

r 0 through 9 indicates one of ten two-word inventory records in a block.

aaaa is the address of the block of records on tape.

Part numbers 000000 through 099999 are stored on the even lane of the magnetic tape and part numbers 100000 through 149999 on the odd lane.

In the coding which follows, the r digit is multiplied by 2 to obtain the correct drum address for a record within a block. The balance information is the first word. The relation between the position of these words and the number of the record within the block is:

Record	Balance Word
0	00
1	02
2	04
3	06
4	08
5	10
6	12
7	14
8	16
9	18

Features which could be added to the subroutine illustrated are checks for re-order, negative balances, oversupply, and non-valid part numbers.

All transaction data is sorted on the last four digits of the part number before it is put into the computer. Records of parts whose numbers end in the same four digits are located near each other in different lanes. For example, the record for part 085000 is near the midpoint of the tape on lane 0, and the record for part 115000 is near the midpoint of the tape on 1. Sorting on six digits would be inefficient, since updating would proceed all along one lane, and then, after a rewind, all along the other lane. The four-digit sort allows the search to proceed across both lanes toward the far end of the tape. The processing of all transactions is completed by the time the end of the tape is reached.

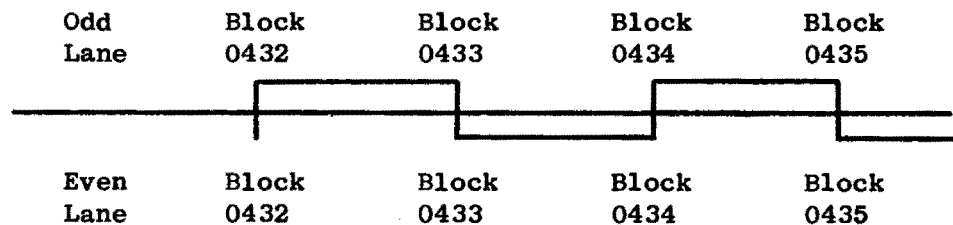

Program

Location	Command	Remarks
6980	CAD 5010	Store Part Number in A Register
6981	EX 7007	Extract surplus digits
6982	SR 0004	Shift four digits to R Register
6983	CIRA 0001	Reposition digits in A Register
6984	SL 0004	Shift digits to A Register
6985	AD 7004	Add a constant for search
6986	ST 6988	Store Search Command
6987	STC 6997	Store Search for backspace
6988	()	Search for inventory record
6989	CC 6988	Cycle if not ready to search
6990	CAD 5010	Store part number in A Register
6991	EX 7006	Extract surplus digits
6992	M 7005	Multiply by constant two
6993	STC 7008	Store result
6994	SB 7008	Set B Register
6995	0 0110 MTR 8000	Read inventory record from tape
6996	CC 6995	Cycle if not ready to read
6997	()	Search to backspace
6998	1 0000 CAD 4000	Store inventory balance in A Register
6999	AD 7009	Add change to inventory balance
7000	1 0000 STC 4000	Store new balance
7001	0 0110 MTW 8000	Store updated record on tape
7002	CC 7000	Cycle if not ready to write
7003	CU _____	Transfer to read next transaction

Constants

Location	Constant	Remarks
7004	0 0010 42 0000	Constant for Search Command
7005	0 0002 00 0000	Constant for Multiplication
7006	0 0000 01 0000	Constant for Extracting
7007	0 0000 10 1111	Constant for Extracting

Transaction Storage

Location	Remarks
5010	Part Number for Transaction
5011	Net change for Part Number Balance on Hand

Figure VIII. Program for Example II.

On one reel, the inventory records of this problem can be expanded to accommodate an additional 50,000 parts without a program change.

Example III

Set up insurance policy information on magnetic tape so that it can be found by policy number. The policy number, ten digits long, has no relationship to the address of the policy record on tape.

If each policy has a 40-word (400 character) record, it occupies two blocks on tape. To set up this record on a tape reel, it is preferable to store the records associated with consecutive policy numbers on different lanes. A part of each tape segment can be set aside for a table or dictionary relating the policy number to its tape address.

If ten blocks on each lane are set aside for the dictionary, 400 policy numbers can be stored in this space. For efficient handling in the program, this space is used to store only 390 policy numbers, and the succeeding 390 blocks on each lane are used to store the two-block records for the 390 policies. The first 400 blocks on two lanes, a total of 800 blocks, hold a 390-term dictionary (leaving a ten-word space to spare in the 20 blocks) and 390 policy records in 780 blocks.

The tape addresses of the dictionary blocks are 0000 through 0009 in the even lane and the same in the odd lane. These blocks are transferred to the drum, occupying cells 0000 through 0399. (However, only 0000 through 0389 are used.)

The input to the system, on cards, is in policy number sequence. Each input number will be searched for in the dictionary, and since the numbers are in sequence, this search will be in the forward direction only, proceeding from the last number found in the dictionary.

DICTIONARY STORAGE CELL FOR POLICY NUMBER		TAPE ADDRESS OF POLICY RECORD
	0 = Even head 1 = Odd head	
0000		0 0010 0011
	(Words 0000 - 0199 came from even lane 0000 - 0009; 1 0001 words 0200 - 0399 came from odd lane 0000 - 0009.)	1 0010 0011
0002		0 0012 0013
.		.
.		.
.		.
0388		0 0398 0399
0389		1 0398 0399

The drum address of the policy number now has a clear relationship to the tape address of the policy record. An even-odd check of the drum address establishes whether the record is in the even or odd lane, and the drum address can be converted to the tape address by adding 10 if the drum address is even; by subtracting 1 and adding 10 if the drum address is odd. In the program which follows, the 10 to be added is contained in the TAPE SEARCH command constant in cell 1050. The same constant designates tape unit 1. The drum address is checked for even or odd by shifting its last digit to the sign position with a CIRA 0009 and then comparing signs with a known word (OSGD). If the last digit is odd, the subtraction of 1 and the designation of the odd head are accomplished in one operation by adding 0 0099 99 9999. For example, if the drum address is 0 0000 00 0383, adding 0 0099 99 9999 will produce 0 0100 00 0382. The addition of the tape search constant, 0 0010 42 0010, will then produce the TAPE SEARCH command, 0 0110 42 0392.

START

Read Dictionary from
Magnetic Tape to
Memory Locations
0000 - 0399

Read Input Transaction Card
Policy number into 6000.
Type of transaction and other
necessary data into 6001-6019.

Search Dictionary for Policy Number.

Location	Command	
1000	6100 CAD (0000)	Compare dictionary number with policy number.
1001	SU 6000	
1002	NOR 1010	Change control if equal.
1003	CAD 1000	Modify command to pick up next number in dictionary if not equal.
1004	AD 1008	
1005	CC	
1006	STC 1000	
1007	CU 1000	
1008	0010 00 0001	

Manufacture and store SEARCH command

1010	CAD 1000	
1011	EX 1052	Bring dictionary address to A and test for even or odd head.
1012	CIRA 0009	
1013	OSGD 1021	
1014	CC 1017	
1015	CIRA 0000	Even head
1016	CU 1019	
1017	CIRA 0000	Odd head
1018	AD 1051	
1019	AD 1050	Add constant in either case.
1020	ST 1022	Store SEARCH command
1021	STC 1062	
1022	(SEARCH)	

The next series of commands may be set to do any type of useful work while the SEARCH is proceeding. Eg., testing the type of transaction or printing the results of the previous policy transaction.

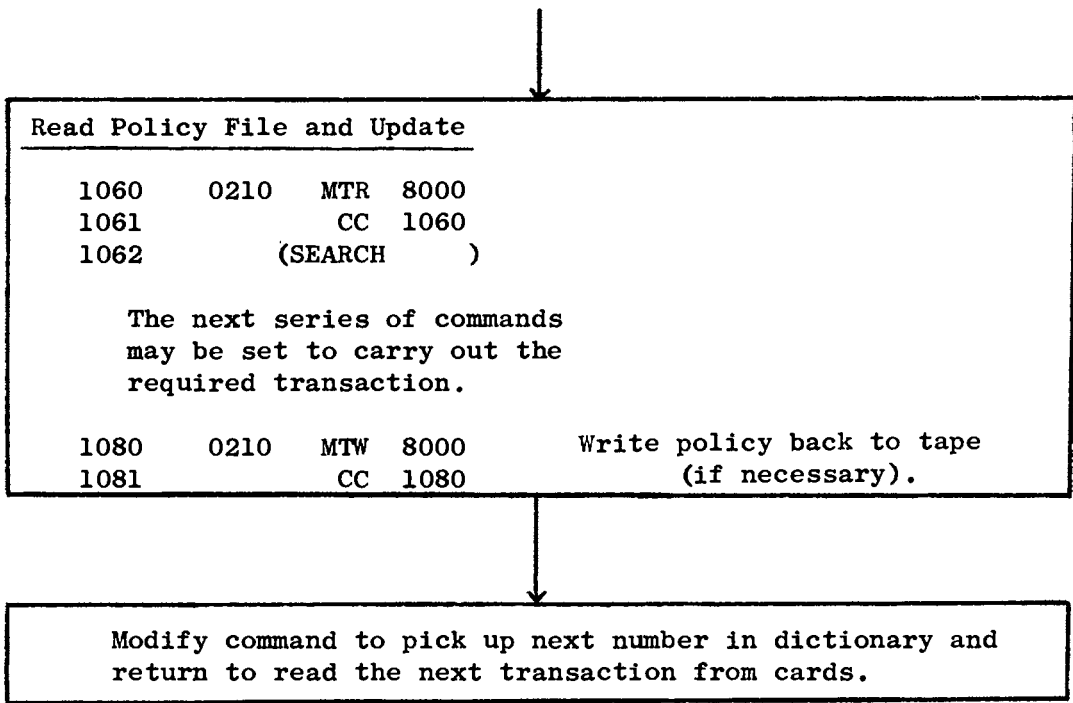

CONSTANTS

Location	Constant
1050	0010 42 0010
1051	0099 99 9999
1052	0000 00 1111

The commands following 1062 in the program do the actual processing of tape information which may be a change of beneficiary, change of address, recording of claims, recording of premium received, recording of loans, or obtaining information to answer various inquiries from the policy holder. If the dictionary were expanded to two words per policy, with the second word being the premium due date, this type of file arrangement could be used for premium billing, with current date compared each day against dictionary entries.

As the file and the program are now constituted, processing will continue until the repeated addition of cell 1008 (0 0010 00 0001) to cell 1000 (0 6100 CAD 0000) has caused overflow after 390 additions, and command 1005 changes control to read the next dictionary and the new TAPE SEARCH constant to the drum.

The next dictionary, also stores in 0000 through 0399 on the drum, comes from even lane 0400 through 0409 and odd lane 0400 through 0409.

<u>Storage Cell</u>	<u>Tape Address</u>
0000	0 0410 0411
0001	1 0410 0411
.	.
.	.
.	.
0398	0 0798 0799
0399	1 0798 0799

Instead of adding 10 to the drum address, the TAPE SEARCH command constant nōw adds 410, and reads 0 0010 42 0410.

BURROUGHS

●
● **ELECTRONIC**
● **DATA**
● **PROCESSING**
● **SYSTEMS**

Burroughs Corporation



ELECTRODATA DIVISION

460 SIERRA MADRE VILLA, PASADENA, CALIFORNIA