

**IBM Southern Pacific
system design report**

**Total
Operations
Processing
System**

march-1962

This document contains information of a proprietary nature. ALL INFORMATION CONTAINED HEREIN SHALL BE KEPT IN CONFIDENCE in accordance with the terms of the joint study agreement between International Business Machines Corporation and Southern Pacific Company Incorporated dated June 6, 1961. The illustrations in this report are artist's conceptions of the system equipment.

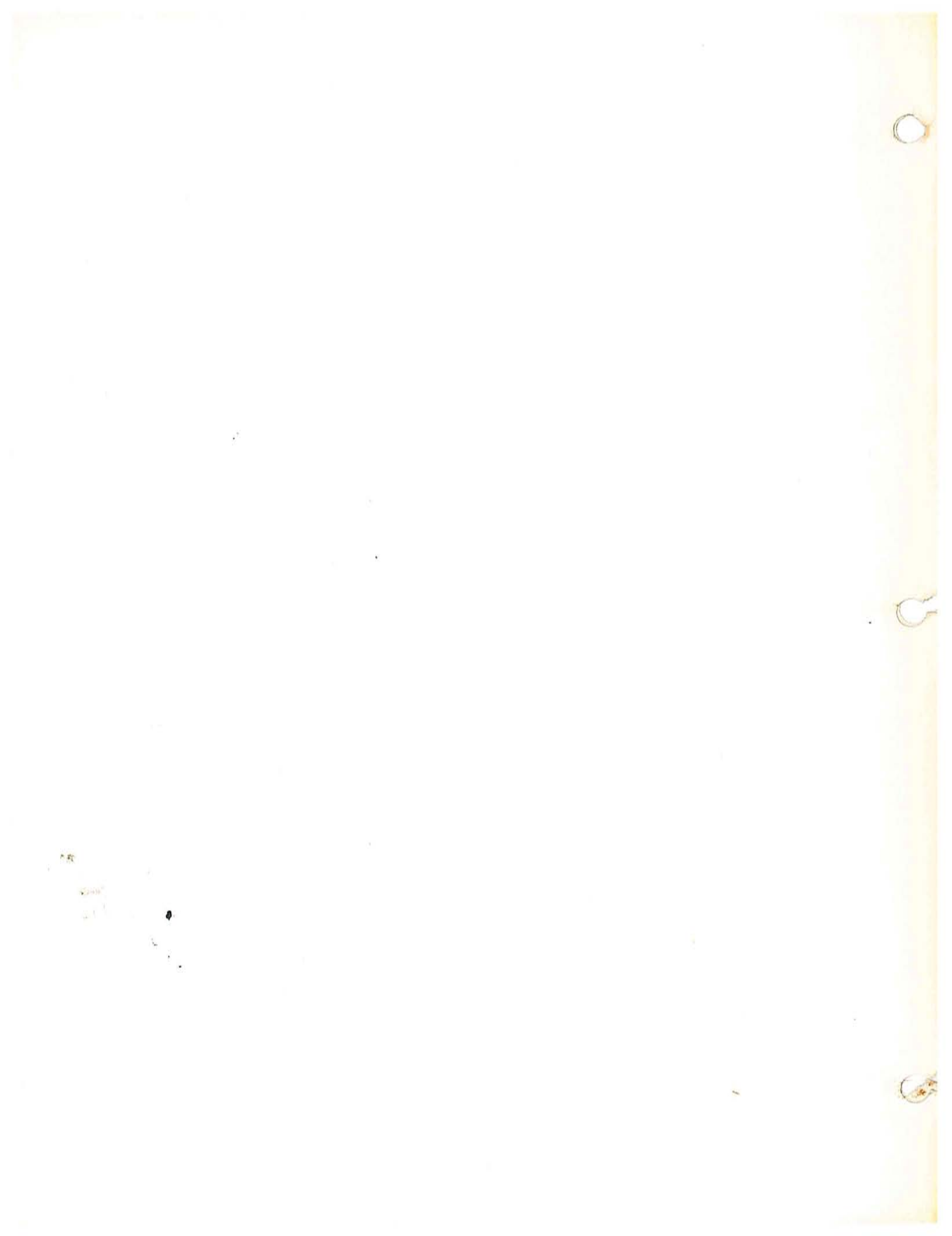

This report is submitted as the design of the Total Operations Processing System (TOPS). The system was designed by the Southern Pacific Company - International Business Machines Corporation Joint Study Team to meet the requirements developed by the Procedures and Evaluation Group.

PROCEDURES AND EVALUATION

| IBM | Southern Pacific |
|------------------|------------------|
| A. D. Dingle | G. S. Sines |
| J. B. Bazley | R. H. Bradley |
| T. C. Bieg | C. C. Cather |
| J. M. Lemon | M. P. Gregovich |
| M. J. O'Callahan | L. C. Scherling |

The Procedures and Evaluation Group was supported in their efforts by three groups at the IBM Data Systems Division Product Development Laboratory at Poughkeepsie. The System Specification Group was responsible for the program analysis, equipment specifications and system reliability. The System Analysis Group was responsible for data reduction and evaluation, simulation and system performance. The Communications Support Group was responsible for line testing, line layouts and communication equipment specifications.

In addition to these groups, many individuals in both Southern Pacific and IBM contributed their experience and time in support of the project.

D. J. McCoy
Project Manager

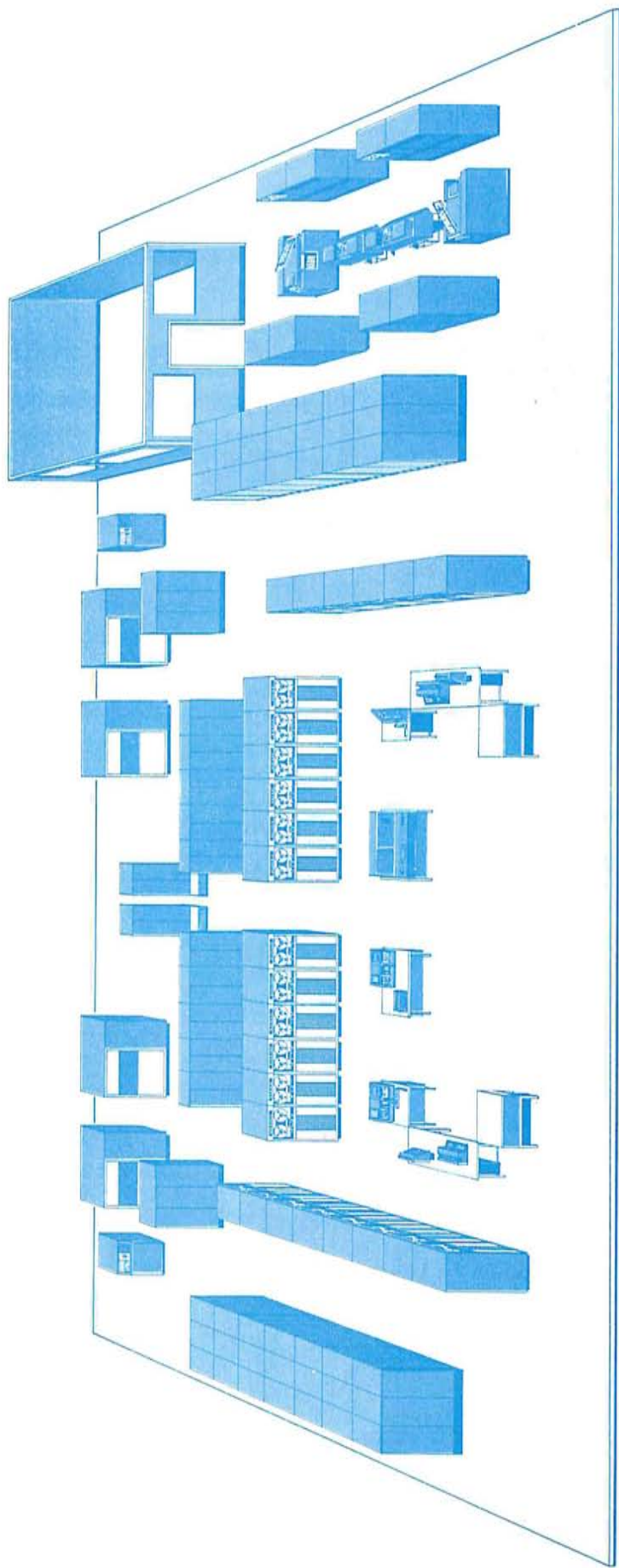

CENTRAL SYSTEM (Artist's Conception)

INTRODUCTION

In June, 1960, IBM Corporation and the Southern Pacific Company agreed to determine the data requirements of the railroad industry in order to explore the feasibility of designing a TELE-PROCESSING System (communications based data processing) to meet the needs of a railroad. A joint study group was formed at that time to undertake the development of a Total Operations Processing System (TOPS).

A preliminary report was submitted by the study team in October, 1960 affirming the feasibility and desirability of TOPS and defining its scope and objectives. As a result, the study team began the design of a data collection and reporting system for the functions associated with the movement of carload freight on the Pacific Lines. Later, an extension was made to include carload freight on the Texas and Louisiana Lines, Pacific Electric, Northwestern Pacific and San Diego and Arizona Eastern Lines.

The prime considerations in designing the TOPS System were to:

1. Reduce the clerical burden in yard offices, agencies and traffic offices by transferring it to the central processor in the TOPS System.
2. Furnish management at all levels with more accurate and timely information to enable them to improve the control and operation of their area of responsibility. This will enable faster movement of freight to sidings and at the same time improve the utilization of freight cars, locomotives and crews.

The TOPS study team concentrated on the specification of procedures that would meet these objectives. This work was carried on with a knowledge of the latest developments in data processing equipment and techniques. As a result, the need for the types of equipment described functionally in the preliminary report was confirmed. That is, the TOPS System would require:

1. Remote Input and Output (I/O) Units.
2. Data Transmission Facilities (S. P. Communications Lines).
3. A central processor which would include a data exchange, a processing unit and large capacity high speed random access files.

The I/O units have the ability to automatically transmit the data that is prepared locally over communication lines, and the ability to receive data originated elsewhere. In developing the procedures, the field team specified the functional requirements of the I/O units required in each application area. This influenced the design of, and resulted in modifications to, I/O equipment being designed. The field team also prepared the schematic maps contained in the appendix which show representative movements of trains and switch engines in each division. These maps, together with a knowledge of the Southern Pacific System, were used by the field team to determine the locations of the I/O units; the units are located in 132 yards or junctions, 62 agencies, 53 traffic offices, 12 dispatchers' offices, 5 car distributors' offices and 99 small stations. The agency I/O unit is called a Waybilling and Transmission Set and the unit for small stations is referred to as a Card Reader and Transmission Set.

Southern Pacific Company

Southern Pacific's communications network will link the remote I/O units to the data exchange (IBM 7750 Programmed Transmission Control). This unit of equipment has the ability to receive information from communications lines, check the accuracy of transmission, and relay it to the processor or re-route it to one or more I/O units. The data exchange will also accept data from the processing unit for transmission to I/O units.

The processing unit will control the flow of data between the data exchange and the random access files (IBM 1301 Disk Storage Units). It will also perform the necessary computations, logical decisions and rearrangement of the data. Where data is required for conventional data processing, the processing unit will write the information on magnetic tape which will be available to the data processing center.

The random access files provide the processing unit with the ability to go directly to any record in the file. This facility is essential for the TOPS System. The responses required to eliminate record keeping in yard and traffic offices could not be met if records were stored on magnetic tape. If magnetic tape were used, a particular record could be obtained only by a time consuming record-by-record search of the tape. Random access files will also provide the ability to quickly and accurately associate waybill data for a particular car that is generated at various locations and at different times.

Procedures also call for regional processing centers at San Francisco, Portland, Los Angeles and Houston for printing freight bills, handling the cash application and preparing reports for car distributors.

The following examples illustrate the operation of the TOPS System. Figure I-1 shows a simplified equipment configuration as it will be used in the TOPS System.

On train departure, the consist will be transmitted by the I/O unit at a yard to the data exchange which will relay it to the processing unit. The records in the random access files for the cars and trains involved will be updated and used to prepare the advance consist. The processing unit will then send the advance consist to the data exchange which will select the appropriate communication circuits(s) and transmit the advance consist to the I/O unit at the next yard.

A car tracing inquiry from an I/O unit in the traffic office will be sent to the processing unit via the data exchange. The processing unit will obtain the proper record from the random access files, select the information required and send it to the data exchange. Again, the data exchange will select the appropriate circuit and transmit the response to the traffic office which initiated the inquiry.

At specified times, the processing unit will compile status reports for yardmasters. The processing unit will obtain the pertinent records for a yard from the random access files, extract the required information and send the report to the data exchange for forwarding to the I/O unit serving that yard.

This System Design Report describes the field procedures and the analyses that were performed at the IBM Development Laboratory to determine the specifications of the I/O units, the communication requirements for the I/O units and data exchange, and the specifications of the central processor. An implementation schedule and consideration of reliability and maintenance aspects are also included. A brief description of the contents of each section is given on the following page:

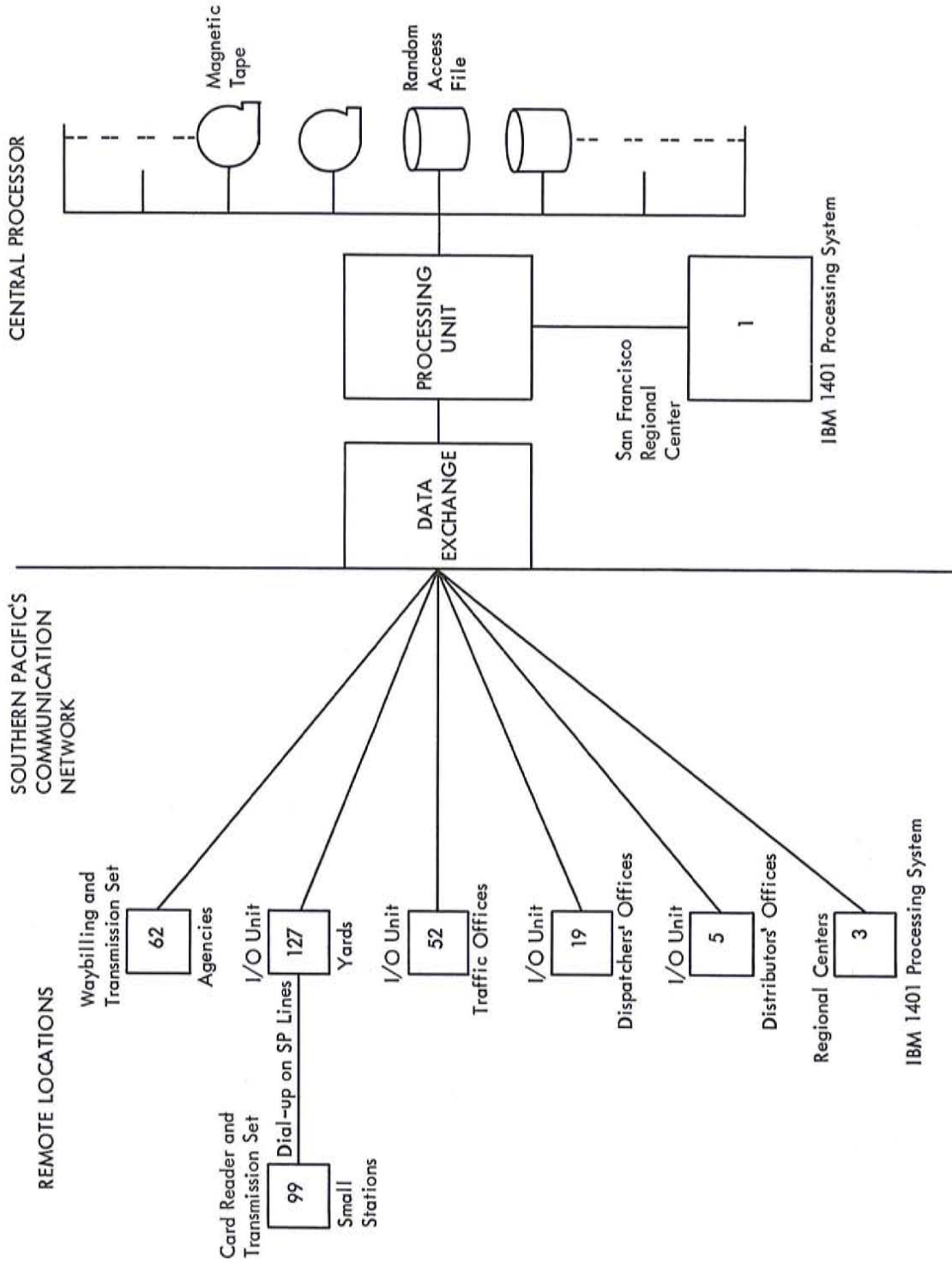

FIGURE I-1 SIMPLIFIED EQUIPMENT CONFIGURATION FOR THE TOPS SYSTEM

Procedures are written for the three application areas: Accounting, Operating and Freight Traffic. They describe the information that is entered into the TOPS System, the manner in which it is entered, the information that is produced and how it will be used.

The section on programming analysis gives an estimate of the total size of the application programs and the manpower required to write them. A description of the operation of the data exchange is presented, and is followed by an analysis of its programming requirements. The supervisory program required to monitor the operation of the processing unit and the features of diagnostic and standby programs are discussed. Lastly, the file organization is stated, followed by a detailed description of a representative program from each of the three application areas.

The communications analysis presents the specifications for the interface between the I/O units and the communication lines and between the communication lines and the data exchange. It also contains the results of line tests and a layout of the lines and I/O units on them for the TOPS System.

The section on system analysis presents the approach used to evaluate the TOPS System. It is presented in four parts: Data Reduction and Analysis, Central Processing Unit and Files, Data Exchange and Communication Lines. This analysis was performed to establish equipment requirements and was based upon data furnished by the field team, estimates from the program analysis and the equipment characteristics. The basic data used for the analysis is presented in the appendix.

The equipment specifications contain a list of the numbers and types of all the IBM equipment required for the TOPS System in the remote locations and for the central processor. Where these products are not familiar to Southern Pacific Company personnel, a description is provided. The operation of the equipment is described, including the transfer of the operation to standby units.

The implementation schedule was developed to take advantage of the operations and geography of the Southern Pacific System, as well as to provide maximum benefits as soon as practical. The field implementation has been coordinated with manufacturing schedules for the equipment.

The reliability of the TOPS System is discussed, including alternate equipment and standby procedures. The maintenance aspect of the TOPS System is considered and includes a list of Customer Engineering locations serving the various installation points.

In reaching the conclusions and recommendations contained in this report, every effort was made to become familiar with the operations and problems through visits to locations on the railroad. In fact, many of the thoughts underlying the procedures were obtained from individuals in the field.

TABLE OF CONTENTS
ACCOUNTING PROCEDURES

| | Page |
|--|------|
| DATA ORIGINATION AND FLOW | 1-2 |
| Local and Interline Forwarded Traffic | 1-2 |
| Waybill Preparation | 1-3 |
| Interline Received Traffic | 1-7 |
| Intermediate Traffic | 1-7 |
| Changes and Additions to Waybill Data | 1-7 |
| Terminating Traffic | 1-9 |
| CENTRAL FUNCTIONS | 1-10 |
| Output Data | 1-10 |
| Review and Corrections | 1-11 |
| Rating and Revising | 1-11 |
| Coding | 1-11 |
| Preparation of Re-entry | 1-12 |
| Weight and Charge to Follow Shipments | 1-12 |
| Diversions | 1-12 |
| Control of Revenue | 1-13 |
| Demurrage Records | 1-13 |
| BILLING AND CASH APPLICATION | 1-13 |
| Freight Bill Assembly | 1-14 |
| Preparation of Transmission | 1-14 |
| Regional Processing of Billing Data | 1-15 |
| Regional Records and Distribution of Documents | 1-16 |
| Cash Application | 1-16 |
| Regional Processing of Master Records | 1-17 |
| Contentions | 1-18 |
| Demurrage Billing | 1-18 |
| Central Control Accounts | 1-18 |
| ALTERNATE PROCEDURES | 1-18 |
| Output to Central Data Processing | 1-18 |
| ROUTE CODING | 1-20 |
| EXTENSION OF APPLICATIONS | 1-20 |

LIST OF ILLUSTRATIONS

| Figure | | Page |
|--------|---------------------------------|------|
| 1-1 | Waybilling and Transmission Set | 1-1 |

ACCOUNTING PROCEDURES

The accounting procedures for the TOPS System utilize the following concepts:

1. Capturing complete carload waybill data at consolidated points (LCL is not included).
2. Using timely accounting and operating data for audit control of revenue.
3. Coding, rating and revising, centrally, prior to preparation of freight bills.
4. Central processor preparation and distribution of freight and demurrage bills.
5. Centralized control of outstanding carload freight bills and demurrage bills.
6. Simplified application of cash to outstanding carload freight bills and demurrage bills.
7. Automatic preparation of input to data processing applications utilizing waybill data.

The basic inputs to the central processor are waybill data and car movement information. Waybill data entry will be made at approximately sixty points on the system. Procedures associated with the flow and entry of bills of lading and waybill data are flexible, and have the ability to handle the exceptions encountered in all operating conditions.

Entry of waybill data will be accomplished automatically as the waybill is prepared on a Waybilling and Transmission Set (Figure 1-1) which is functionally the same as an office typewriter.

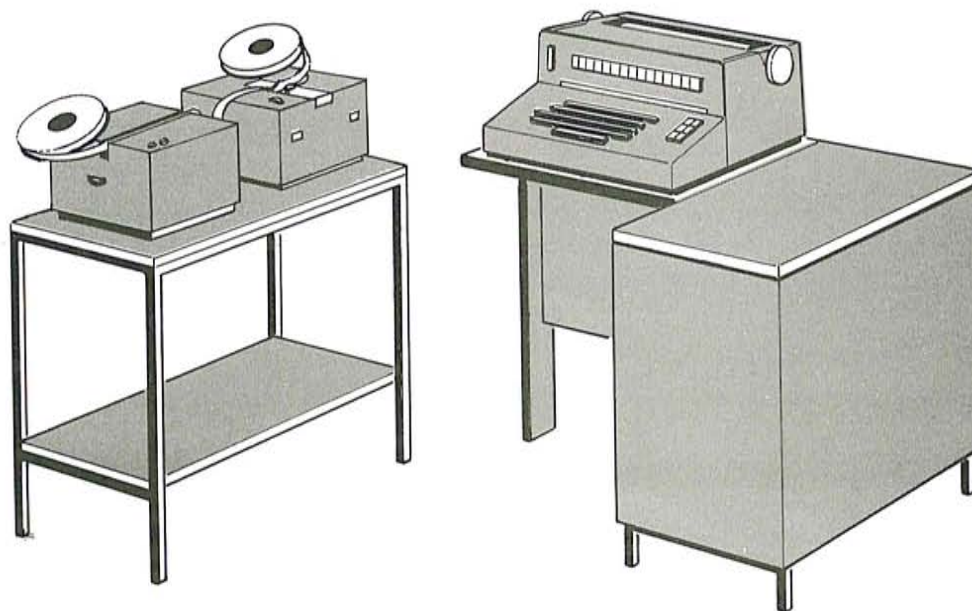

FIGURE 1-1 WAYBILLING AND TRANSMISSION SET

These sets will require little additional operator training and few control decisions. They can be easily moved to other locations as volumes or operating patterns change.

Car movement data entry is described in the Operating Procedures of this report.

The following procedures will handle the accounting aspects of the TOPS System.

DATA ORIGINATION AND FLOW

Local and Interline Forwarded Traffic

Bill of Lading Movements

Shipper order copies of bills of lading originated by shippers will reach agencies in accordance with present procedures. When convenient or possible, two copies of the shipping order portion of bills of lading will be obtained from shippers. When two copies are not furnished and a second copy is needed, a photocopy will be made at specified waybilling points.

Assignment of Audit Control Numbers

A block of consecutive waybill control numbers will be assigned to each agency station. These numbers will be applied sequentially to all shipping order copies of bills of lading for which each station is responsible. The size of the block to be assigned to each station will be determined by the volume of traffic originated by that station. Different series within each block will be used to identify traffic categories. These series will be designated by the Auditor of Revenue Accounts.

Small agencies not equipped with Waybilling and Transmission Sets will keep a log of all bills of lading; the bills of lading are assigned control numbers at such stations. This record will identify control number, date, car initial and number and shipper.

Bill of Lading Check and Coding

The origin agency will ascertain that the bill of lading information is complete and be responsible for determination of the following data which will be added to the bill of lading where it is desirable to code locally:

Station From Code

Station To Code (if local shipment)

Shipper Code (if applicable)

Routing (interline shipments)

Type of weight to be used in accessing charges:

Actual - railroad or shippers's tested scales;

Estimated - agreed tariff classification, or minimum.

Freight Billing Non-Credit Customers

All shipments moving prepaid from a non-credit patron will have to be freight-billed locally to effect collection of charges prior to release of the shipment. The charges will subsequently be entered to the central processor at the time of waybill preparation.

Waybill Preparation

Waybill entry to the central processor will be concentrated at selected points on the railroad, as determined by volume and train movements. In those instances where origin agencies have a Waybilling and Transmission Set, the data will be captured at that point. Shipments originating at points not equipped with such a set will have entry made as follows:

1. Shipments moving to or through a waybilling point will move with the bill of lading to the first of such points, and waybill data will be captured there.
2. Local shipments moving short of a point equipped with a Waybilling and Transmission Set will move with the bill of lading to the destination, and entry to the system will subsequently be made at an assigned location. In some cases, local operations will permit the bill of lading data to be forwarded to the data entry point from the origin agency.
3. Interline shipments going off-line short of a TOPS waybilling point will be waybilled at the origin agency and move with the waybill to the interchange. A copy of the waybill will then be sent to an assigned point for entry to the central processor.

In some instances, it will be necessary to furnish the bill of lading at the data entry point prior to arrival of cars from an outlying agency. This condition occurs when interline forwarded shipments move out of the waybilling point soon after the inbound train arrives. In such instances, the data necessary for preparing the waybill to move with the shipment can be furnished in advance by telephone, teletype, messenger or other means, depending upon time requirements and local communication facilities.

In other cases involving close connections on shipments at a data entry point where communication facilities do not permit advance waybilling, it will be desirable to prepare waybills at the origin agency. These waybills will move with the car, and copies will be sent to the TOPS waybilling point for entry to the central processor.

The Waybilling and Transmission Set is designed to place the maximum burden of identifying data on the central processor, to provide ease of operation, and to permit efficient preparation of any of the variety of waybill formats currently used.

The waybill typist will:

1. Indicate waybill format by entering the form number.
2. Type information in prescribed fields on the waybill in the accustomed manner. (The sequence of entries can be in any order and in any

Southern Pacific Company

place in the space provided on the waybill form).

3. Correct errors detected during the typing of the waybill by correctly typing over the erroneous entry, or by crossing out the entry with an "X" indication and typing the correct entry elsewhere in the field provided.
4. Enter data that overflows the space provided on the waybill by typing a single special character to indicate where the overflow starts and another special character to indicate the end of the overflow.
5. Be able to enter information other than that normally used in a specific area on the waybill by preceding the data with a special character to identify it as special information that does not normally appear in the space used.
6. Enter single characters in spaces provided at the bottom of the waybill to indicate the following:
 - a. Cancellation of erroneous billing, i.e. when a typist makes errors and wishes to retype the waybill in its entirety.
 - b. Class of Traffic - Interline Forwarded, Interline Received, or Local. (Intermediate traffic is discussed later in this section).
 - c. Type of Billing - Prepaid or Collect.
 - d. Manifest Indication - Enter indication for shipments not to be included on manifest lists.
 - e. End of Waybill - A special character to indicate to the central processor that the waybill is complete and available for transmission.

Transmission will be monitored to detect any transmission errors and, when required, data will be retransmitted automatically. This check will be accomplished through signals generated automatically by the equipment - not by the operator. The waybill typing can proceed independently of transmission since the input to the central processor is temporarily stored and the data is called for when the communication system is ready to accept it.

The Waybilling and Transmission Set can be used as a regular electric typewriter when not required for waybilling. The type style can be easily changed for various typing tasks.

To reduce equipment costs it is desirable to prepare waybills as close to the Operating input-output units as possible. Furthermore, the movement of cars on bills of lading to assigned TOPS waybilling points makes waybill preparation at yard offices desirable. This will reduce delays and eliminate messenger handling of documents between yard offices and agencies.

Interline Forwarded Waybill Preparation

All interline forwarded shipments will have to move forward from a TOPS waybilling point with a waybill. All interline waybills, other than skeleton weight

Southern Pacific Company

and charge to follow bills, will show weight, rate and extension. It is important that the rate shown on prepaid waybills is highly accurate to minimize the need for subsequent corrections. Rates for interline shipments will be determined at the origin agency or the waybilling point.

Interline shipments will have first priority for waybill preparation. As previously described, exceptional shipments making close time connections will have waybills prepared in advance, and copies will be forwarded to an assigned TOPS waybilling point for entry to the central processor subsequent to the car movement. All interline shipments will move to junctions with waybills and train movement will not be delayed for paper preparation.

The formats used in conjunction with interline shipments will include the following:

1. Standard AAR, Form 98 Waybill
2. Perishable Waybill
3. Transit 11 inch Waybill
4. Transit 20 inch Waybill
5. Cotton Waybill
6. Livestock Waybill
7. Advances Only Waybill
8. Other Required Waybill Formats

Local Waybill Entry

Data entry for local traffic, including audit control number, will be made from information contained on shipper order copies of bills of lading. Cars can move through to destination on a copy of this document. In those situations where a car is moving through the TOPS waybilling point, and the shipper has not furnished two copies of the bill of lading, a photocopy will be made. When the original document is copied, it will be stamped to indicate that a copy has been made. This will allow entry of data for local shipments to take place subsequent to car movement.

When cars terminate short of a TOPS waybilling point, input will be made from the document forwarded to the assigned point by the destination agent, or in some cases, by the origin agent.

On multiple car shipments of such commodities as ore, logs, wood chips, sugar beets, and similar large-volume repetitive movements, a manibill entry format will capture all data necessary for processing.

On single car shipments, data will be captured from the following waybill formats:

1. Local Carload Waybill
2. Standard AAR from 98 Waybill

3. Local Manibill
4. Perishable Waybill
5. Local Cotton Waybill
6. 11 inch Transit Waybill
7. 20 inch Transit Waybill
8. Livestock Waybill
9. Other Required Formats

It should be noted that local shipments need not be rated at agencies unless the shipment requires the collection of charges prior to movement, or involve outbound transit.

Advances Only Charges

Charges advanced at agencies or other points where service is performed will be included on regular waybills or, if the charge is incurred after completion of the waybill, on an advance only format. This data will be supplied to the central processor as the appropriate document is typed at a TOPS waybilling point.

Prepaid Non-Credit Shipments

Waybill data for shipments involving prepaid billing for non-credit customers will include the amounts collected and identify the billing agency.

Empty Car Waybills

Audit control numbers assigned to empty car waybills will be entered at the data entry points for those waybills requiring accounting control. Each entry will consist of the control number and car initial and number.

Weight and Charge to Follow Shipments

Skeleton waybill data will be followed by complete revenue waybill data entry to complete the processing of weight and charge information. Local shipments will often move on weight and charge skeleton waybills rather than bills of lading since some cars are released and forwarded before the agency receives the shipper order copy of the bill of lading.

Transit Shipments

All transit records will be maintained locally and complete waybill data for each outbound transit shipment will be made available for entry to the TOPS System.

Interline Received Traffic

Movement of Waybill Data From Interchange

Waybills received from connecting carriers will move with their respective cars to destination agencies. Cars interchanged at TOPS waybilling points will have waybills copied for entry to the System and each document that is copied will be stamped to indicate that it has been copied. Shipments received at outlying junctions and moving through a TOPS waybilling point will have copies made. Waybills received in interchange and terminating short of a TOPS waybilling point will be forwarded to an assigned station by the destination agency. A sequential audit control number can be assigned and included with the input to effect additional document control.

Data Entry

Entry of interline received waybills will be performed on a Waybilling and Transmission Set by indicating format and transcribing the data from a copy of the received waybill. Special notation will be made to indicate the skeleton weight and charge to follow waybills received.

Intermediate Traffic

Movement of Waybill Data From Interchange

Waybills for intermediate traffic will move with cars to the next connecting carrier. When these shipments are received in interchange, a copy of the waybill will be made for data entry into the TOPS System. Bridged shipments received at a non-waybilling point, and moving through a waybilling point, will have copies made at the waybilling point for subsequent entry into the System. Traffic received at a point not equipped with a Waybilling Set and not moving through such a point prior to delivery to the next carrier, will have an abstract of the waybill prepared at an appropriate agency for subsequent entry into the System.

Data Entry

Intermediate movements will be abstracted on the 922-B format currently used for reporting waybills passing junctions, and entered into the TOPS System through a Waybilling and Transmission Set.

Changes and Additions to Waybill Data

Diversions

Agencies and freight traffic offices will make diversion requests by entering an appropriate code, Car Initial and Number and descriptive information such as new destination, new consignee and new routing. Subsequent changes to the waybill or bill of lading will occur at yard offices accomplishing these diversions, and notification of completion of the diversion will be sent to the central processor. For shipments that are diverted from local to interline forwarded, the yard office will arrange for the preparation of an interline waybill to move with the car to the off-going junction.

Southern Pacific Company

Since acknowledgement of the diversion is all that is required by the central processor, it will not be necessary to enter any additional waybill data.

Scale Weights

Weights for cars weighed enroute, and not included on the initial waybill entry, will be entered to the central processor by the yard office that weighs the cars. Weight information will be added to the document in the form of a scale ticket or a manual entry, and will move with the car.

Other Charges Incurred Enroute

All other charges, such as icing and feeding livestock, that are incurred after initial waybill entry will be typed in Advances Only waybill formats for transmission to the central processor.

Corrections

The input of a correction to a waybill will include the car initial and number and waybill format number, followed by the correct data in the appropriate field. It is not necessary to retype a waybill; only the changes must be recorded on it.

Transfers

If the contents of a car are transferred to another car for any reason, the car initial and number of the new car will be recorded on the document moving with the car. Then the initials and numbers of both cars will be sent to a TOPS waybilling point for entry into the System.

Transloads

The received waybill for a transloaded shipment will move with the car containing that part of the original shipment that is going to final destination. In the event the car moving to final destination is not the inbound car, the new car initial and number will be added to the document moving with the car and will be entered into the TOPS System to update the waybill data. A new waybill will be prepared for each outbound car; this will contain a cross-reference to the received waybill and will be transmitted to the central processor.

Consolidations

Accomplishment of consolidations will be entered to the central processor at consolidation points by cross-referencing waybill numbers and car initials and numbers of cars consolidated to the waybill covering the outbound car. It should be noted that consolidations and transloads occur only at points equipped with Waybilling and Transmission Sets.

Piggyback Shipments

It is necessary to separate the data entry for cars on which trailers move from the data entry for the trailers. A skeleton waybill entry containing reference to each

Southern Pacific Company

of the trailers will be made for each railroad car moving with piggyback lading. Trailers will move on detailed waybills containing reference to the car on which they are transported.

It will be necessary to prepare waybills for movement of local as well as inter-line piggyback shipments. Bills of lading often contain data for more than one trailer, and contents of some trailers often move to different consignees.

Government Shipments

Shipments for the U.S. Government will move to destination with the Government bill of lading for signature by the receiving governmental facility. The destination agent will then forward the Government bill of lading to the General Accounting Office in San Francisco for billing.

Data entry to the TOPS System for these shipments will include the Government bill of lading number, car initial and number, and an audit control number.

No Bills

In the event a yard office discovers that a loaded car has become separated from its waybill or bill of lading, inquiry to the central processor can be made for waybill information. In the event there is not a waybill available in the central processor, the inquiry will be answered with previous movement data to enable the yard office to contact the origin agency and obtain the necessary waybill data. The yard office will then make arrangements for the preparation of any necessary waybills to move with the car.

Terminating Traffic

Reporting Documents

Each destination agent will periodically mail, to the Auditor of Revenue Accounts, the movement documents for each car terminating at his agency and the non-agency points for which he is responsible.

Freight Billing Collect Shipments to Non-Credit Patrons

When payment of freight charges is required prior to delivery of a car to a non-credit patron, the agent concerned will prepare a freight bill from the waybill or a copy of the bill of lading moving with the car. He will present the freight bill to the patron for payment, and retain a copy of the bill. A revised freight bill will be subsequently prepared by the TOPS System and sent to the agent, the agent will compare the revised freight bill with a copy of the freight bill he made; if there is any difference, he will advise the Central Rating and Revising Bureau and prepare an additional billing or make a refund, as appropriate.

Weight and Charge Revenue Waybills Received From Other Carriers

All weight and charge revenue bills received from other carriers will be entered into the central processor from the most convenient TOPS waybilling point,

Southern Pacific Company

and will be forwarded to the Auditor of Revenue Accounts.

Rule 10 Cars

The destination agent will forward all manifests received for battery shipments or Rule 10 Cars to the Central Rating and Revising Bureau for rating and preparation of the freight bill.

Shipper Order Notify Shipments

The Operating Department will hold for delivery all cars moving on shipper order notify bills of lading until the agent concerned obtains the properly endorsed original bill of lading, effects any necessary collection, and/or releases the car for delivery.

Constructive Placement

Upon advice from the Operating Department that a car has been constructively placed, the agent will prepare, and mail to the patron a notice of this placement as required by demurrage tariffs and rules. Placement data will be entered into the TOPS System through an operating input unit.

Team Track Delivery

The agent concerned will notify patrons of all team track deliveries. This information will be given to the agent by the Industry Service Center (as defined in the Operating Procedures). At smaller stations the information will be obtained by the agent's examination of a waybill or a bill of lading. Time of postal notification will be entered into the central processor together with a car initial and number reference.

CENTRAL FUNCTIONS

Output of Data

Complete waybill data entered into the TOPS System will be produced centrally for review, coding, rating or revising, and correction. Several times a day, the central processor will output those waybills that have all the data required for freight billing and/or coding. Each waybill will be followed by an area which will be used to enter codes and to check critical fields. A list of waybills will be prepared in a sequence that will facilitate the rating and coding operations. Additions or changes to the waybills will be re-entered to correctly assess charges, establish accounts receivable, and provide coding for subsequent central processing.

Re-entry Code

Each waybill produced centrally will contain a document number assigned by the central processor. This number will assure that the data re-entered will be associated with the proper record.

Southern Pacific Company

Review and Corrections

All waybill data will be reviewed for completeness and proper field definition. When information is garbled, missing, or obviously incorrect, the necessary corrections or additions will be made.

If information vital to freight billing and further processing is missing and cannot be readily determined centrally, it will be necessary to contact the origin agent or the data entry point to get the necessary data.

All corrections or additions to the waybill data will be written on the document that is produced centrally.

Rating and Revising

The waybill output will be distributed to revising clerks who will determine rates applicable to Local and Interline Received shipments. If desirable, Interline Forwarded Prepaid shipments can be revised at this time.

Revising Freight Charges for Non-Credit Patrons

Shipments to or from non-credit customers will be billed at the agency concerned. The amount of the bill will be included in the waybill data entry. If subsequent review of this data by the Central Revising Bureau indicates that an additional charge or a refund is required, the re-entry will be coded to signal the central processor to apply the correct rate and to prepare either a freight bill for additional charges due, or a notice of a refund to offset any overcharges.

Coding

The listing of waybills will be forwarded to coding clerks who will assign a 6-digit commodity code to each waybill if it was not included at the time of waybilling. The clerks will also assign a 5-digit numeric patron code to all waybills involving on-line shippers and consignees having credit. Shipments involving charges to a non-credit patron will be assigned a code for the agency responsible for collection. No coding of accounting districts will be required for on-line originations and/or terminations. Furthermore, off-line originations or terminations in states having only one accounting district will not require coding. For those shipments originating or terminating at off-line stations in states which have more than one such district, it will be necessary to manually code accounting district "from or to". Interline forwarded collect and intermediate shipments will not involve any central rating or revising. The interline forwarded waybills will be reviewed for completeness and missing codes will be assigned. Intermediate traffic data will be reviewed for completeness of station from, station to, on-coming junction and road, off-going junction and road, charges and weight, waybilling road and destination road and shipper and consignee.

Preparation of Re-Entry

Re-entry information will fall into two categories. First, applicable rates, revisions and codes will be punched on cards and re-entered. Secondly, for any major changes to or rearrangement of the document, the re-entry will be prepared on a set similar to that used for preparing waybills. In this way, all data necessary to affect field corrections or rearrangement of the document will be re-entered.

Manifests from destination agents for Rule 10 Cars will be received by mail and rated; entry to the central processor will be accomplished with a Waybilling and Transmission Set using a freight bill format.

Weight and Charge to Follow Shipments

Entry of skeleton weight and charge data will be held in suspense by the central processor and subsequently associated with detail revenue waybill data. Interline forwarded collect shipments that move on a weight and charge-to-follow basis will be coded after entry of the revenue data.

On shipments involving collection of charges by Southern Pacific, entry of the revenue waybill will release the waybill data to the Central Rating and Revising Bureau. Subsequent re-entry of codes and rates will automatically release the freight bill. The central processor will make periodic checks for outstanding weight and charge waybills, and initiate tracing if data is not received in a specified time.

Diversions

Diversions of Shipments Not Involving S. P. Collection of Charges

At the time a diversions request is received, the diversion data will be added to the waybill record in the central processor. When the central processor is notified of the accomplishment of a diversion, the Central Rating and Revising Bureau will be advised of the changes made to the waybilling so that any coding changes can be made.

Diversions of Shipments Involving S. P. Collection of Charges

If a diversion request is received prior to the transmission of a freight bill, the central processor will not release the freight bill. When notification of the diversion accomplishment is received, central output of the updated waybill information will be prepared for any necessary rating, coding and re-entry. A new freight bill will be assembled in the routine manner to replace the unreleased freight bill. When a diversion is accomplished subsequent to the release of a freight bill, the central processor will cancel any charges previously assessed. In addition, new output will be prepared by the central processor for coding and freight billing the diverted shipment.

Control of Revenue

The central processor will periodically examine the series of control numbers assigned by each agency to movement documents. In the event of an incomplete series or duplication of numbers, tracing will be initiated automatically. Waybill input for all cars moving as loads will be automatically checked against the operating record. In the event that waybill data is not entered into the central processor, an output message will be sent to the appropriate TOPS waybilling point.

Records of all tracings will be maintained. These can be used for periodic review of each agency to insure better control and performance.

Demurrage Records

The accounting procedures for processing and billing demurrage charges are basically dependent upon input and subsequent association of the operating data with patron records in the central processor. These records will include such information as patron name, address, type of account and average agreement numbers.

For credit patrons, the demurrage record for each car will be determined by using the inputs of: Car Initial and Number, time ordered for spotting, time spotted, time released, time of constructive placement, and, for team track deliveries, time of postal notification. Reference to the patron code will be accomplished by the shipper or consignee codes for credit patrons on the inbound or outbound waybills. For switch moves, the patron code will be obtained from the spot and spur reference for patrons on industry spurs. Patrons not having credit will have a demurrage accounts receivable entry posted to the account of the collection agent. These entries will be maintained on a straight demurrage basis.

The exception to the above procedures will arise when an empty car is placed for loading at an industry spur or a team track, and is subsequently released without lading, and also when a switch move is made to or from a team track. The agent concerned will prepare an entry to the central processor identifying the patron to be billed.

Bills for all straight demurrage charges will be assembled by the central processor for distribution to regional billing points.

Average agreement entries will be accumulated on a monthly basis to compute any amounts due and prepare the necessary billing. The details for average agreement bills will be processed and distributed over the TOPS System from the central processor; these details will be in the format of PCDB Form 210 and Texas and Louisiana lines form 8248. The bills will show amounts due and will include substantiating details.

BILLING AND CASH APPLICATION

The following procedures utilize the concepts of centralized rating and revising, central processor assembly of freight bill and demurrage bill details, and communications to regional processors located at Portland, Houston and Los Angeles. An

additional center located in San Francisco will not require transmission. Each center will be equipped with an IBM 1401 tape system for handling the application of cash to outstanding bills.

The central processing complex will compile billing details, separate freight bills and demurrage bills by region, and maintain control accounts of the amounts outstanding. Regional and local records will be filed in sequence of transmission and will eliminate the need for separate files of paid and outstanding bills.

Freight Bill Assembly

After the waybill data is checked and rated, or revised, re-entry will be made centrally to complete the data needed for freight billing. The central processor will then assemble freight bills for distribution on the TOPS System. In the case of a local prepaid shipment, it will be necessary to prepare freight bills for both the shipper and the consignee. Twice daily, freight bills will be transmitted and printed at the regional centers at Los Angeles, Portland and Houston. Freight bills will be printed for the San Francisco region, but will not require transmission. System-prepared demurrage bills will be distributed in the same manner. The distribution of bills from the central processor to the regional centers will be determined by the location of the patron receiving the bill:

| | |
|---------------|--|
| Houston | Texas and Louisiana Lines |
| Los Angeles | PE, SD & AE, HI, and Los Angeles, Rio Grande, and Tucson Divisions |
| Portland | Portland and Shasta Divisions |
| San Francisco | NWP, P & SR, VE, and Coast, Western, Sacramento, San Joaquin and Salt Lake Divisions |

Preparation of Transmission

Freight bills will be transmitted in the following sequence: Region, Responsible Agency, Patron, Invoice Number, Freight Bill Number. A sequential invoice number within a region will be assigned for each patron involved in a transmission. Freight bill numbers will be assigned sequentially by region.

The sequence of transmission for demurrage bills will be: Region, Responsible Agency, Patron, Demurrage Bill Number. Demurrage bill numbers will be assigned sequentially by region.

In each case, control totals will be developed centrally and transmitted to the regions with each transmission.

Responsible Agency

The agency in contact with the patron with regard to claims, questions of charges and related matters requiring reference to freight bill details will be considered the responsible agency. Each patron record will include a responsible agency code.

Southern Pacific Company

Self Check Numbers

All freight bill numbers, demurrage bill numbers, invoice numbers and patron codes will include self-check digits supplied by the central system to facilitate subsequent processing.

Regional Processing of Billing Data

Freight Bills

The billing details will be received at the regional centers on magnetic tape. The received tape will be used to print the freight bills and update master tapes containing complete freight bill detail and an abstract record of freight bills outstanding. The master tape will be maintained in the same sequence as the transmission; i. e. , Responsible Agency, Patron Code, Invoice Number, Freight Bill Number. An additional reference tape identifying freight bills within invoice and within patron will be maintained. For those patrons receiving more than one freight bill for a transmission, the regional processor will assemble and print a covering invoice which will identify the patron and each freight bill number and amount. Although the invoice will be printed on a freight bill form, it will be identified as an invoice and will contain a request that it be returned with payments. The processed bills will be balanced to the control totals established centrally.

Demurrage Bills

The received tape for demurrage bills will be used in a manner similar to the freight bill detail tape. Demurrage bills will be printed and a master tape abstract outstanding bills will be updated. However, invoices will not be prepared for demurrage bills. Straight demurrage bills will be processed and distributed daily. Average agreement bills will be processed monthly, with substantiating detail to indicate each car involved. The average agreement processing could be distributed by sending magnetic tapes via air mail to the regional centers.

Extra Copies

A standard number of copies will be produced for all bills. The central patron record will include the number of bill copies required by the patron. When this number exceeds the standard number, the regional processor will continue printing until the desired number of copies is produced. The repeat printings will be identified as extra copies of bills.

Reports of Bills Outstanding

The abstract tape of bills outstanding will be listed daily at each region (after cash application) in the sequence in which it is maintained; i. e. , Type of bill, Responsible Agency, Patron, Invoice Number (freight bills only) and Bill Number.

Regional Records and Distribution of Documents

Regional File

A regional file of detail bill copies will be maintained in the sequence in which they are produced; i. e., Type of bill, Date, Transmission, Responsible Agency, Patron Number, Invoice Number (freight bills only) and Bill Number. A copy of the daily abstract record listing of outstanding bills will be maintained at each regional center.

Responsible Agency Document

Daily, or twice daily, as desired, each responsible agent will receive by mail, copies of new bills and applicable invoices for those patrons for whom he is responsible, together with a copy of the abstract listing of the bills outstanding. The agent will maintain these records in the sequence in which they are prepared; i. e., Type of Bill, Date, Transmission, Patron Number, Invoice Number (freight bills only) and Bill Number.

Patron Bills

Detail bills and applicable covering invoices from the regional center will be mailed to credit patrons. Window envelopes will be used since the correct mailing address will be provided from the central records for all documents prepared. Bills prepared centrally for non-credit patrons will be mailed to the agent effecting local billing. The billing address for such bills will be that of the agent involved.

Cash Application

In most instances, payments on freight or demurrage bills will be made to regional billing centers. If the patron prefers, he can make his payments to the responsible agency, to a local bank or to other collection points. Any payment received at points other than the regional billing point will be deposited locally and advice of the deposit will be forwarded to the regional center. The regional center will process the payments in two basic batches: (1) Payments with identified bill numbers and any applicable invoice numbers, or (2) payments without identification as to bill. Conventional batch cash balancing controls will be established over all monies and documents received.

Full Payment of Identified Invoices

Those payments received covering complete payment of an invoice, with the invoice number identified, will be processed at the regional center as follows:

An adding machine tape total of the amounts paid for each batch of such payments will accompany the source documents (the returned invoice, or agent's advice) to a card punch operator who will punch a card containing amount, Patron Number and Invoice Number for each payment. The punched cards will be batch-balanced to the adding machine tape to control the dollar amounts punched. Any errors will be corrected prior to further processing. When a batch is balanced, the cards will be held for subsequent processing and compared with the outstanding accounts tape. Since self-checking digits will be utilized for patron number and invoice number, and cash amounts

will be balanced as mentioned above, there will not be any need to further verify this card-punching. Furthermore, it should be noted that one card can be used to apply cash to all the outstanding freight bills when an invoice is paid in full.

Partial Payments of Identified Invoices

When the regional center receives payment advice covering identified invoices and applicable freight bills, and the total invoice amount is not paid in full, the processing will be as follows:

Batch controls of amounts paid will be handled in the same manner as full payments to effect dollar control. When freight bills are partially paid, the source documents and control tape will be forwarded to a card punch operator who will card punch a separate card for each freight bill included in the payment, and a special code indicating partial payment and reason. The batch of cards will be balanced to the control tape and held for subsequent processing.

Payments of Identified Freight Bills

When payment advice on a particular freight bill is received at the regional center, the procedures will follow the same pattern as listed above; that is, batch balancing, punching of patron number, freight bill number, amount and the partial payment codes, as necessary.

Unidentified Payments

When the regional center receives payments in which the invoice number or freight bill numbers are not identified, two approaches can be used: First, if it is possible to contact the patron and determine the applicable bills, without having reference to a freight bill detail file, the invoice or freight bill number information will be obtained. Card-punching and processing will be handled as in the appropriate category listed previously.

The second approach utilizes reference to the listing of outstanding freight bills and amounts. If the identity of the payment is in doubt, the patron will be given this information, or further reference to the filed freight bill copies will be made.

In either event, the patron contact will identify the invoice or freight bill and partial payment data necessary for processing in one of the categories defined previously.

Regional Processing of Master Records

The cards punched and balanced from the above procedures will be put on a daily transaction tape, sorted to the sequence in which the master tapes are maintained, and used to update the regional master tape records of freight bills outstanding. If a partial payment of a freight bill is received, the regional processor will prepare a freight bill for the balance due when the transaction tape is processed against the regional master records. Daily analysis of accounts overdue will be prepared at the

region and transmitted to the central processor to advise the Treasurer's office and the Auditor of Revenue Accounts. The previously mentioned listing of bills outstanding will be prepared daily for local use after cash is applied and exceptions are processed.

Contentions

When the regional center processes cash reflecting the contention of a rate, this information will be coded and the Central Rating and Revising Bureau will be advised of this fact for necessary adjustments.

Demurrage Billing

The regional centers will prepare and distribute bills and maintain detail and abstract records for demurrage billing from the received tapes in the same manner as for freight billing. The essential difference in processing is that invoices are not used.

Central Control Accounts

The TOPS System will maintain updated tape records of control accounts of amounts outstanding. These tapes will be processed to ensure that amounts and cash are in balance. Out of balance reports will be distributed to the Treasurer's office, the Accounting Department and the regional centers to effect correction.

ALTERNATE PROCEDURES

The TOPS System provides for the movement of either a waybill or a copy of the bill of lading with all carload shipments. In the event of equipment failure when back-up equipment is not available, the procedure will be to prepare interline forwarded waybills on regular typewriters and move the documents with the cars. When the Waybilling and Transmission Sets are available, the information will be retyped and entered into the System. For local or interline received shipments, entry to the central processor would not be made until the equipment is available, or the documents are forwarded to another location for input to the central processor.

Output to Central Data Processing

The information gathered in the TOPS files will be made available to central data processing functions as needed.

After a waybill has been entered into the system and the central coding function has been completed, the following output, listed according to present format, will be available for processing on the presently installed IBM 7074.

FORMAT A (Obtained directly from the waybill file):

1. Waybilling road.
2. Waybill number.
3. Waybill date.

Southern Pacific Company

4. Station to- use code for on-line, name for off-line.
5. Station from - use code for on-line, name for off-line.
6. Commodity code.
7. Weight (net).
8. Freight.
9. Advances.
10. Prepaid.
11. Freight bill number.
12. Freight bill amount.
13. Traffic type - (Local, Interline Forward, Interline Received, Intermediate).
14. Format code.

FORMAT B:

1. Waybilling road - obtain from waybill file.
2. Waybill number - obtain from waybill file.
3. Consignee accounting district to - obtain from "state to" in waybill file if unique state code relationship. For credit patrons in multiple district states, obtain from patron file. Codes for remaining patrons will be applied during the central coding operation.
4. Shipper accounting district from - same as "district to".
5. Consignee major industry code - obtain from patron file for credit patrons.
6. Shipper major industry code - obtain from patron file for credit patrons.
7. Lead Car I & N - obtain from waybill file.
8. Number of carloads - obtain from manibill or waybill file if more than one car.
9. Consignee's name - obtain from patron file for credit patrons. Derive from compression program for others.
10. Shipper's name - obtain from patron file for credit patrons. Derive from compression program for others.
11. Consignee state code - obtain from waybill file.
12. Consignee plant location code - obtain from Sales and Cost Reporting Program using consignee's name.
13. Shipper state code - obtain from waybill file.

14. Shipper plant location code- obtain from Sales and Cost Reporting Program using shipper's name.
15. Format code.

FORMAT C:

1. Waybilling road - obtain from waybill file.
2. Waybill number - obtain from waybill file.
3. Car I & N for cars in shipment - obtain from manibill or waybill file record.
4. Format code.

ROUTE CODING

It is not contemplated that the TOPS System will affect the present procedures involved in determining the route code for interline received traffic. The data required from the waybill for division processing will be retained on magnetic tape. When the received waybills are reported in from destination agents, a card will be punched for each waybill indicating Car Initial and Number, Waybill Number and Route Code. These cards will be combined with the waybill tape to provide the data required for processing interline settlement.

EXTENSION OF APPLICATIONS

It has been previously established that interline forwarded shipments will move from waybilling points with a completed waybill. This is the general procedure. However, it is well known that there is great time pressure on waybilling perishable traffic in time to make schedules. Accordingly, it is planned to modify this general procedure to allow entry of data to the central processor at the origin station and provide printed interline waybill output at another location.

An example of this will be preparation of input for perishable traffic at Watsonville Junction with waybill output at Roseville. This procedure will allow trains to move to Roseville without delay for waybilling. The work load at Watsonville will be spread over a greater time period and will reduce the need for additional staff personnel to meet peak hour demands.

The same type of procedure could be used at other high volume perishable origination points such as Bakersfield, Fresno and El Centro.

Another area of future development is that of repetitive traffic. It is evident that many carload movements are repetitive in nature. It will be a function of the TOPS System to analyze all waybill data and identify like movements. Each movement of this type will be given a repetitive code number, and the origin agencies will be periodically advised of these codes. The input for local shipments would then be reduced to entering this code and a limited amount of variable data, including car initial

Southern Pacific Company

and number, date, and waybill control number, rather than full waybill information. The central processor would associate this input with its record of repetitive movements and automatically complete the waybill record, including central coding, rating and assembly of freight bill data.

To achieve greater efficiency, the repetitive traffic concept could also be utilized in conjunction with waybill transmission. For shipments that are repetitive in nature, the repetitive code and the variable information would be entered at the waybilling point, e.g. Watsonville Junction. The central processor would fill in the repetitive information and provide a printed waybill at a selected output point, e.g. as Roseville.

Central Filing

Important Features of the TOPS System will include:

1. The ability to check unreported waybills automatically.
2. Elimination of manual sorting of waybills.
3. Simplified reference to filed waybill data.

As local and interline received documents are received in the General Office, a progressive filing number will be assigned to each. No manual sorting will be required. Furthermore, there will not be any handling of interline forwarded waybills or abstracts similar to form 922B on intermediate shipment as complete data will be in exact sort on magnetic tape.

For each received document a card will be punched to indicate waybill number, car initial and number, and the progressive filing number. For interline received shipments, route code will also be punched into this card. These cards will be processed to update magnetic tapes containing detailed waybill information.

A mechanized check of unreported waybills will be made from this data and a listing will be prepared to initiate tracing when required. Monthly, a condensed listing of every waybill will be prepared in waybill sequence within class of traffic and will show the progressive filing number assigned in the General Office. The reported waybills will be filed in the order received, which is in progressive filing number sequence. All reference to waybills will be made to the condensed record which will be compact and in exact sequence. If reference to movement documents on interline received or local shipments should be required, the progressive filing number, which will be shown on the condensed record, will be used to locate the movement waybill in its filing location.

TABLE OF CONTENTS
OPERATING PROCEDURES

| | Page |
|--|------|
| CAR RECORDS | 2-1 |
| RESPONSIBILITY/LOCATION (R/L) AREAS | 2-2 |
| EXAMPLE 1: TRAIN PROCEDURES | 2-3 |
| Dispatcher Places Call | 2-5 |
| Initial Yard Office | 2-6 |
| Departure Report | 2-6 |
| Conductor Enroute | 2-6 |
| Call to Intermediate Yard | 2-8 |
| Intermediate Yard Office | 2-8 |
| Report from Intermediate Yard | 2-9 |
| Train Enroute to Final Terminal | 2-9 |
| Advance Consist to Termination Yard | 2-9 |
| Final Train Performance Report | 2-10 |
| EXAMPLE 2: INDUSTRIAL ZONE PROCEDURES | 2-10 |
| EXAMPLE 3: LARGE TERMINALS | 2-11 |
| EXAMPLE 4: PROCEDURES FOR HOLD CARS | 2-12 |
| Situation and Turnover Report | 2-13 |
| Inquiry Ability | 2-14 |
| MAJOR YARD OFFICE OPERATIONS | 2-14 |
| Work Area | 2-14 |
| Local Records in the Work Area | 2-17 |
| Bad Orders in Yards | 2-21 |
| Service Tracks | 2-22 |
| Assigning a "Hold" Status to a Car | 2-22 |
| Cars on Spot (ISC) | 2-22 |
| Releases | 2-23 |
| Recording Car Orders | 2-23 |
| Spot and Pull Lists | 2-25 |
| Confirmation of Spots and Pulls | 2-26 |
| Diversions | 2-28 |
| Data Items Needed by the Central Processor | 2-28 |
| Situation and Turnover Report | 2-33 |
| Inquiry Ability at a Major I/O Unit | 2-33 |
| Correction Procedures | 2-35 |
| INDUSTRIAL ZONES DIRECTLY ASSOCIATED WITH A MAJOR YARD OFFICE | 2-36 |
| Agents in Zone Areas | 2-36 |
| Interchange in Zones | 2-36 |
| Conductor or Engine Foreman Operating in Zone Areas | 2-36 |
| Pickups and Setouts by Mainline Crews for Zone Spurs | 2-37 |
| LOCAL AREAS NOT ASSOCIATED WITH A SPECIFIC MAJOR YARD OFFICE | 2-38 |
| Conductors Performing Work in Local Areas | 2-38 |
| Agents in Local Areas | 2-40 |
| Car Orders Placed at Local Points with a Card Reader and Transmission Set | 2-41 |

TABLE OF CONTENTS
(CONTINUED)

| | Page |
|---|------|
| Train Originating at Local Points | 2-43 |
| Train Terminating at Local Points | 2-43 |
| Crew Change at Local Points | 2-44 |
| Track Checks from Selected Local Points | 2-44 |
| DISPATCHER PROCEDURES | 2-45 |
| Equipment | 2-45 |
| Report and 24-Hour Line-up | 2-45 |
| Placing a Call | 2-46 |
| Departure Reports and Schedule Revision | 2-46 |
| Train Terminates | 2-47 |
| Train Performance Report | 2-47 |
| Undesignated Car Moves | 2-47 |
| Inconsistent or Missing Data | 2-48 |
| Bad Orders Set Out on Line | 2-49 |
| CAR DISTRIBUTION PROCEDURES | 2-49 |
| Introduction | 2-49 |
| Equipment | 2-50 |
| Organization | 2-50 |
| System and Regional Car Distributors | 2-50 |
| Car Distributors' Reports | 2-51 |
| Control Orders | 2-56 |
| Filling Car Orders | 2-59 |
| Car Orders from Local Points | 2-62 |

LIST OF ILLUSTRATIONS

| Figure | | Page |
|--------|---|------|
| 2-1 | Example of R/L Areas for a Division | 2-4 |
| 2-2 | Pickup/Setout Card Set | 2-7 |
| 2-3 | Operating I/O Unit | 2-15 |
| 2-4 | Format for Cards Produced by the Central Processor for Local Use | 2-18 |
| 2-5 | Track Check List | 2-19 |
| 2-6 | Car Order Form | 2-24 |
| 2-7 | Spot and Pull Lists | 2-27 |
| 2-8 | Advance Consist | 2-31 |
| 2-9 | Situation and Turnover Report | 2-34 |
| 2-10 | Proposed Master Report | 2-52 |
| 2-11 | Empty Car Location Detail List | 2-54 |
| 2-12 | Car Order List | 2-55 |
| 2-13 | Disposition Monitoring List | 2-57 |

OPERATING PROCEDURES

The following operating procedures describe the methods by which information vital to the efficient operation of the railroad will be collected from all key locations, and quickly transmitted to the central processor of the TOPS System. The central processor will check and assemble the information into the proper formats and distribute it rapidly to the specific locations and individuals responsible for necessary actions. The TOPS System is designed to provide improved control over movement and utilization of all freight equipment and freight trains.

CAR RECORDS

Many times, equipment which is not normally included in TOPS records will be hauled in freight trains, and therefore, must temporarily be included in the system. Thus, when passenger cars or special work equipment is to be handled in freight trains, the local yard initiating such movement will treat these cars as having been received at interchange. When passenger cars are put back into passenger service, or work equipment is delivered to its assigned rip track, they will be interchanged out of the TOPS System. As currently planned, the specifications for the TOPS System described in this proposal will provide a detailed record of these cars' movements only while they are handled by those areas of the railroad normally associated with the movement of freight cars.

The central processor will maintain a separate record for every freight car on the Southern Pacific System. These records will contain:

1. Identity Information - Car initial and number, type, selected information from the equipment register.
2. Clean Status - Current grade or commodity cleaned for, when and where last cleaned, last commodity held.
3. Current Load - Commodity, SP destination, gross weight, special instructions to operating personnel about the movement of this load.
4. Current Status - Current location, status (loading, unloading, etc.), length of time in this status.
5. Future Dispositions of Car - Assigned service for this car, home route or next disposition of car after release from current load as indicated by car distributor.
6. Movement History - Junction at which car is received, record of first wheel move after a change in status, the most recent wheel move, the current status of car, and reference to the waybill of load carried.

This car record will be compiled in the core storage of the central processor when the car is received by the SP at an interchange track; it is held in disk storage and continually updated until the car is delivered to another carrier.

RESPONSIBILITY/LOCATION (R/L) AREAS

In the TOPS System, the railroad has been divided into areas corresponding to the main functions performed and their geographical location. Within each area a specific position will be held responsible for keeping track of functions it performs, and entering the information into an I/O unit conveniently located for that purpose. In general, the types of responsibility/location areas, and the persons held responsible therein, are as follows:

1. Yard - (Responsibility: Yardmaster) - The central processor will maintain a separate record for each major yard area; in this record it will associate, to each major yard, the car records for every car currently in that yard. When a car is to move from a yard, or is to be detained therein, the yardmaster must indicate to the clerk at the I/O unit in his yard office the nature of the circumstance, so that this can be entered into the I/O unit immediately.
2. Industrial Zones - (Responsibility: Local Yard Office or Industry Service Center) - Industrial areas will be organized into zones, which will correspond, basically, to the engine assignments handling cars to the various spurs. A specific yard office, Industry Service Center, or local agent will be held responsible to indicate to the central processor the various changes of status that occur to cars on spurs in the zone to which they are assigned. They are also responsible for certain types of contacts with the patrons served by these spurs.
3. Interchange Tracks - (Responsibility: Local Agent or Yard Office) - Whenever cars are received from or delivered to a foreign carrier, or equipment for which the TOPS System has no record is transferred to or from a freight train, a specific local person will be held responsible for compiling the initial record for each such car received as well as assuring the completion of proper interchange documents covering the moves.
4. Remote Sidings and Industry Tracks - (Responsibility: Dispatcher) - Most information about car movements and change of status along the local lines will be read into the TOPS System from yard offices in the field; however, the dispatcher will be able to monitor these entries and will be held responsible for either knowing, or being able to find out, the exact situation along the line, and then be able to aid in detecting and correcting errors in information received by the central processor about local movements.
5. Trains, Transfer Cuts, Industrial Switchers - (Responsibility: Conductor or Engine Foreman) - Any crew moving cars between the responsibility/location areas above will be held responsible for submitting at the termination point information about the cars they have handled and what they have done with them. In most instances, the initial yard office will aid the conductor or engine foreman by providing him with many of the basic documents already prepared which need only to be completed. The engine foreman or conductor will be held responsible for accurate reporting of his moves, and

for aid in correcting errors or omissions in his reports. The central processor will compile centrally all wheel reports, blind siding reports, and pickup-setout reports from the single set of documents the crew submits at the end of its tour of duty.

6. Cleaning and Rip Tracks - (Responsibility: Track Foreman) - Whenever cars are spotted or pulled on a cleaning or rip track, a list of the cut will be read into the central processor. For each car pulled, the foreman will indicate to the yard office his release and classifications.
7. Hold Cars - (Responsibility: Responsibility/Location Area Requesting Change in Status) - Whenever a car is placed in hold status it will be listed in the car's record, together with an indication of the reason for holding, length of time held, and responsibility/location area where release and disposition is expected. This area will be held responsible for indicating this release promptly to the clerk at the I/O unit in the local yard office who can then initiate movement as well as indicate the release information to the central processor. The central processor will be able to prepare lists of cars being held by any responsibility/location area and indicate the reason for holding and the elapsed time, to date, in hold status.
8. Service Requests - (Responsibility: Foreman or Clerk in Work Area Involved) - Whenever a car is to be weighed or iced, vents changed, diversions recorded, etc., the identity of the responsibility/location area making the request will be entered in a service request record, together with a reference to indicate to the clerk at the I/O unit in the local yard office the information required by the central processor about the service performed. When the central processor receives the requested information, the reference will be eliminated from the service request record. The central processor will be able to list, for any particular yard location, the types of servicing that have been requested for cars in the locality, and the period of time that the information requested has been outstanding.

A typical list of the responsibility/location areas for a division is shown in Figure 2-1. For each of these, the central processor maintains a separate record associating data for all cars currently in the area; a summary of these indicates the general "situation", and a list of the outstanding information for which the area concerned is currently being held responsible. Once the requested data has been read in, or a car is transferred to another responsibility/location record, references to these will be eliminated from the records associated with old responsibility/location areas so that the data reflects the current status at any one time.

EXAMPLE 1: TRAIN PROCEDURES

From the standpoint of the central processor, the train procedures can be considered similar to the organization of a record for each train, and the subsequent collection of the various types of data from the appropriate sources in the field. The central processor obtains the various items of data for a train record by initiating a request to the I/O unit normally assigned the task of collecting the type of data

LOWER SAN JOAQUIN VALLEY LINES

Saugus
MOJAVE Plamdale Turn
Lone Pine Turn
Searles
Monolith Turn
Creal
YARD
Tehachapi
BAKERSFIELD Yard
Clean Track
Arvin Turn
Edison Turn
Upper Yard Indus.
Oil City Turn
Buttonwillow Indus.
Buttonwillow Turn
Line: Bakersfield/Famoso
Famoso Yard
Line: Famoso/Delano
Delano Yard
Line: Delano/Tipton
Line: Tulare/Fresno
Goshen Junction Yard
Fowler
Hanford Branch
Poterville Yard
Richgrove Turn
Line: Exeter/Strathmore
Exeter Yard
Visalia
Line: Fresno/Ivanhoe
Fresno Yard
Zone 18
Merced Yard
Zone 1
Zone 3
Zone 8
Zone 9
Zone 15
Zone 16
Zone 16
Clean Track
Biola Turn

FIGURE 2-1 EXAMPLE OF R/L AREAS FOR A DIVISION

needed. It does this by issuing "data request" cards which indicate to the clerk at the I/O unit the exact nature of the information wanted. The clerk at the I/O console holds the various "data request" cards until the information indicated on one of them is available. He then uses the appropriate "data request" card, and punches the desired information, as indicated by instructions, to enter the information into the TOPS System. The entry of the "data request" card directs the information into the correct section of the correct train record and also relieves the clerk at the I/O unit of the task of punching identity information in addition to data. All of the data is collected as soon as it is available in the field, and placed into a record held in the central processor for the specific train involved. As this data is entered into the record, the central processor applies various checks against it to detect errors. Selected information then becomes available to other persons and departments for performing their own tasks associated with the train's operation. The central processor is thus helping to expedite the movement of traffic by co-ordinating the flow of much of the information needed for train operation and by absorbing many of the chores of record keeping.

Dispatcher Places Call

When the placement of a call is confirmed, the dispatcher or his clerk will enter an identifying code into his I/O unit together with the train designation and other selected information. Upon receipt of this, the central processor sets up a skeleton record for this train, places the information from the dispatcher in the appropriate place in the record, and initiates a series of procedures which, over the next 8 to 24 hours, will collect all the data about the train movement. These procedures will error-check the data and insert it in the proper location in the train record. The data in the train record is of four types:

1. Train Identity Information - Which consists, initially, of an estimated schedule and is subsequently revised as the operation proceeds until, at its termination, it has been completely replaced with the actual performance. In addition, this section of the train record will be used to complete reports about the train's operation that will be referenced whenever inquiries are received about the train's status. It will be used in the preparation of "ink" reports for management.
2. Engine Information - A record of the locomotives used, the stations between which they operated, and whether they were dead-in-tow or in helper status.
3. Crew Information - Which includes the names and man numbers of employees associated with the train operation, their on and off duty times, and a code for the claims for special payment allowances they have submitted by virtue of the operation of this train.
4. Car Information - In which a current consist is maintained while the train is enroute; this information ends with a complete record of all car movements performed by the train. In addition, this section keeps a record of any services performed on the freight cars by the crew (weighing, changing vents, etc.), and also a reference to any car movements requested by the car distributor or dispatcher; the reference describes special car movements which they perform.

Initial Yard Office

The first data collection routine initiated by the central processor will check, as a result of the dispatchers call, the train record for the types of information required from the initial yard office, and the types of information to be disbursed to other yard offices. First, the central processor will compile a message to certain yard offices that will identify the train, and give the call time and estimated schedule. It will then issue to the initial yard office four "data request" cards to collect the following information:

1. Initial train consist, with set-off points.
2. Engine units used and which of these is the lead unit, and which are dead-in-tow or helpers.
3. Departure time.
4. Crew man numbers and on-duty time.

The receipt of these cards will not only confirm the placement of a call to the yard office personnel, but will also signal the clerk at the I/O console to start collecting this information. Using these "data request" cards, together with cards that he either punches or pulls from his local records, the clerk will input each of these items of data as soon as it becomes available to him.

Departure Report

When the central processor has received the information it has requested from the initial yard office, it will summarize this information and compile a departure report. This report will be issued immediately to the dispatcher through his I/O unit. The dispatcher can use this report to note items of information he would otherwise call to the field to collect, and check the remaining items for accuracy or for the possibility of a schedule revision. Using his I/O unit, the dispatcher will be able to correct both his estimated schedule and the data reported by the initial yard office. If he does revise the schedule, the central processor will compile a message that identifies the train and indicates the new estimated schedule; this message will be sent to the yard offices listed in the estimated schedule.

Conductor Enroute

Upon leaving his initial terminal, the conductor will be supplied with a conductor's train list and the movement documents for the cars in his train (waybills and bills of lading). As he sets out or picks up cars enroute, in lieu of preparing a wheel report, blind siding report, or pickup-setout report, the conductor will be asked to prepare a document for each car so handled. This form will be printed on an IBM punched card; a supply of these will have been provided the conductor as a regular part of his supplies. These pickup-setout cards have been designed such that when a conductor sets out a car and fills out his setout card, he simultaneously prepares a pickup card for the subsequent conductor. Figure 2-2 illustrates the pickup-setout card. The pickup card

is left locally with the car, and is later picked up by another conductor at the same time that the car is picked up. When the setting out of any car is known in advance at the initial yard office, the clerks at that point will have already prepared the cards for the conductor's use and have placed them in the fold of the appropriate waybill.

| CAR INITIALS & NO. | TYPE | L/E | S. P. DESTINATION/TAG NO. | OWT | CONDUCTOR | LAST 4 DIG. CAR NO. | SET OUT TIME | REASON | LOCATION |
|---|--------------|------------------|---------------------------|---------|-----------|---------------------|--------------|-------------------------|-------------------------------|
| COMMODITY/COMMODITY CLEARED FOR | | | | | | 0000 | 0000 | 000000 | 000000 |
| SET OUT REASON | 0 FOR LOAD | 3 CONST. PLACE | 6 INTERCHANGE DEL. | 9 OTHER | | 03 04 07 08 | 09 10 11 12 | 13 14 15 16 17 18 19 20 | 21 22 23 24 25 26 27 28 29 30 |
| | 1 FOR UNLOAD | 4 STORAGE - HOLD | 7 INTERCHANGE REC. | | | 1111 | 1111 | 111111 | 111111 |
| | 2 RELOAD | 5 FOR CONNECTION | 8 BAD ORDER | | | 2222 | 2222 | 222222 | 222222 |
| SPECIAL INSTRUCTIONS | | | | | | 3333 | 3333 | 333333 | 333333 |
| <p align="center">— GENERAL INSTRUCTIONS —</p> <p>1. COMPLETE ABOVE SECTION ON THIS "SET OUT" REPORTING CARD AND ATTACHED "PICK UP" REPORTING CARD - USE CARBON.</p> <p>2. DETACH "PICK UP" REPORTING CARD AND LEAVE WITH CAR.</p> <p>3. TURN IN THIS "SET OUT" REPORTING CARD AT TERMINAL.</p> | | | | | | 4444 | 4444 | 444444 | 444444 |
| | | | | | | 5555 | 5555 | 555555 | 555555 |
| | | | | | | 6666 | 6666 | 666666 | 666666 |
| | | | | | | 7777 | 7777 | 777777 | 777777 |
| | | | | | | 8888 | 8888 | 888888 | 888888 |
| | | | | | | 9999 | 9999 | 999999 | 999999 |
| | | | | | | 03 04 07 08 | 09 10 11 12 | 13 14 15 16 17 18 19 20 | 21 22 23 24 25 26 27 28 29 30 |

| CAR INITIALS & NO. | TYPE | L/E | S. P. DESTINATION/TAG NO. | OWT | CONDUCTOR | REL-EASE TIME | PICK UP TIME | REASON | S. P. DEST. OR TAG NO. |
|---|--------------|------------------|---------------------------|---------|-----------|---------------|--------------|-------------------------|-------------------------------|
| COMMODITY/COMMODITY CLEARED FOR | | | | | | 0000 | 0000 | 000000 | 000000 |
| SET OUT REASON | 0 FOR LOAD | 3 CONST. PLACE | 6 INTERCHANGE DEL. | 9 OTHER | | 03 04 07 08 | 09 10 11 12 | 13 14 15 16 17 18 19 20 | 21 22 23 24 25 26 27 28 29 30 |
| | 1 FOR UNLOAD | 4 STORAGE - HOLD | 7 INTERCHANGE REC. | | | 1111 | 1111 | 111111 | 111111 |
| | 2 RELOAD | 5 FOR CONNECTION | 8 BAD ORDER | | | 2222 | 2222 | 222222 | 222222 |
| SPECIAL INSTRUCTIONS | | | | | | 3333 | 3333 | 333333 | 333333 |
| <p>RELEASE INFO.</p> <p>RELEASED BY: _____ REL. TIME: _____ REL. DATE: _____ FINAL DEST. & JUNCT. _____</p> <p>LEAVE CARD WITH CAR: 0 EXPLOSIVES, 1 RESTR. SPEED, 2 DANGEROUS, 3 SEE WAY BILL, 4 CLEAN, 1 WEIGH, 2 NO WEIGH</p> | | | | | | 4444 | 4444 | 444444 | 444444 |
| | | | | | | 5555 | 5555 | 555555 | 555555 |
| | | | | | | 6666 | 6666 | 666666 | 666666 |
| | | | | | | 7777 | 7777 | 777777 | 777777 |
| | | | | | | 8888 | 8888 | 888888 | 888888 |
| | | | | | | 9999 | 9999 | 999999 | 999999 |
| | | | | | | 03 04 07 08 | 09 10 11 12 | 13 14 15 16 17 18 19 20 | 21 22 23 24 25 26 27 28 29 30 |

FIGURE 2-2 PICKUP/SETOUT CARD SET

Thus, when the conductor arrives at his final terminal, he will turn in the following:

1. His movement documents.
2. A pickup card for every car picked up.
3. A setout card for every car set out.

These documents will be used by the clerk at the I/O unit in the conductor's terminating area to read into the TOPS System information the central processor will use for compiling any of the reports currently prepared by the conductor himself, and for maintaining the other car movement records.

Call to Intermediate Yard

When appropriate, the dispatcher will read into his I/O unit a code indicating a call to an intermediate yard, the train identification and the call information. The central processor will not only add this information to the existing train record, but will also compile a message to each other intermediate yard office, and the terminating yard office, that will identify the train and give the call information for reference. It will then start the series of routines to collect information about the new crew, and any changes of consist or locomotives.

Intermediate Yard Office

Prior to the arrival of the train at the intermediate yard, the I/O unit will issue an advance consist. The advance consist will normally be in block form except for those cars to be set out locally at the intermediate yard; these will be listed in detail. Corresponding to the items in the advance consist, the yard office will simultaneously receive a punched card for its local records and for re-entering the train's consist. If the intermediate yard desires a detailed list of any of the blocks on the consist which were not printed in detail, this can be obtained, together with punched cards, by re-entering the appropriate block card into the I/O unit.

Together with the advance consist and cards, the clerk at the I/O console will receive "data request" cards indicating the information the central processor desires about operation in his area. These are as follows:

1. Actual arrival and departure time of train.
2. New crew man numbers, and on-duty time.
3. New consist out of terminal, if changed.
4. Changes to locomotive consist.
5. Off-duty time of retiring crew, with a code for claims submitted by the crew for special allowances.
6. Pickups and setouts performed by the crew going off-duty.

As the intermediate yard office collects the above information, it will use the data request cards to enter it into the TOPS System.

Report from Intermediate Yard

When the intermediate yard has entered the various types of data requested, the central processor will compile this information into two reports that are issued to the dispatcher, or dispatchers, involved:

1. A summary of the departure information, crew, locomotives and blocks consist of the train out of the intermediate yard.
2. A summary of all the information the central processor has received pertaining to the first part of the train movement into the intermediate yard office, including arrival time, crew off-duty time, a code for claims submitted, and changes in the consist and locomotive usage.

As before, the dispatcher can use those reports to note items of information he has not yet collected directly from the field, and can check the information entered into the train record about the train movement. He will then have the ability to correct any of the items in the train record, revise the schedule, validate claims arising from exceptional circumstances of train operation and/or add an explanatory note to the report describing peculiarities of the operation.

Train Enroute to Final Terminal

The conductor out of an intermediate yard will be provided with the previous conductor's train list and a supplement indicating new cars added to the train at the intermediate yard. As with the previous conductor, he will prepare documents for each pickup and setout he performs enroute and submit these with his movement documents at his terminating point.

Advance Consist to Termination Yard

Prior to the arrival of the train at the terminating yard, the central processor will issue a detailed consist listing every car handled out of the preceding yard in the train. This listing will be accompanied with punched cards for each car and "data request" cards for the following types of information:

1. Crew off-duty time, and a code for claims submitted by the terminating crews.
2. Arrival time.
3. Modifications to the locomotive consist made while the train was enroute.
4. Pickups and setouts performed by the crew.

As the items of information indicated by the data request cards are obtained by the clerk at the I/O unit in the terminating yard office, they will be immediately entered into the local I/O unit. At this time, it will be evident if any conductor has not properly reported pickups or setouts enroute; if not, the terminating yard office will initiate the appropriate correction procedure and secure any missing information.

Southern Pacific Company

Final Train Performance Report

As with previous dispatchers, the final dispatcher will receive a summary of the data input by the final yard office. This summary will enable the final dispatcher to make corrections or additions to the train record regarding the final part of the train's operation. With the entry of the final dispatcher's corrections or indication of approval, the central processor will check through the train record to ascertain that all data requests have been received and all logical checks have been passed. Also, a final train performance report will be compiled for management purposes, and a copy of the entire train record will be read onto magnetic tape for subsequent accounting procedures. Utilizing IBM 7074 equipment in the SP data processing center, it is contemplated that the following uses can be made of the complete train records:

1. Preparation of interchange records.
2. Preparation of wheel reports and other documents describing car movements.
3. Preparation of monthly car records for railroad and private line cars.
4. Reproduction of train sheet data for the checking of payroll data.
5. Preparation of reports showing the location of locomotives and their usage in freight service.
6. Preparation of freight train car mileage and tonnage reports.
7. Preparation of train performance records.
8. Preparation of cost analyses.

EXAMPLE 2: INDUSTRIAL ZONE PROCEDURES

For almost every industrial zone there will be an associated specific yard office where a clerk will have access to an I/O unit, and will be in close communication with the yardmaster and train master who supervise crews in the zone. This office will be called the Industry Service Center (ISC) for the zone. It will collect information from the patrons and crews in the zone, pass what is appropriate to other operating personnel at the yard office, and collect the information required to maintain the desired records in the central processor. Patrons will be asked to communicate all releases, car orders, and placement instructions directly to their Industry Service Center. Upon receipt of this information, the clerk at the ISC will immediately punch the data into his card records and transmit the information to the central processor. In this way the central processor will maintain an up-to-date picture of the industrial zone which can be used by the car distributors, dispatchers and other supervisory personnel to effect close control as cars change status.

Where desirable, the central processor will be able to compile and issue a message to the destination yard to provide advance notice of a car to be delivered to a local patron in a local industrial zone. Such notices can be received soon after the car is released or received at an interchange. These messages can be used for a variety of tasks:

1. To ascertain a placement instruction, in advance, for every car which the zone will receive.
2. To re-enter into the car record a reference as to the zone and spur number to which the car is to be directed, so that this information can be made available to remote yard offices on their advance consists and switch lists. This procedure enables remote yards to pre-switch a train directly without having to maintain their own records of placement instructions covering the terminating point.
3. Patrons in the zone can be notified of the receipt of the car on Southern Pacific Lines; thus, the patron can more quickly locate the car as well as make advance preparation for the car's unloading.

When an engine crew is about to depart the yard area with cars to be spotted in the industrial zone, the ISC will prepare a list for the engine foreman with the following sections:

1. A spot list, indicating where cars he is taking from the local yard are to be placed.
2. A zone track check, listing all cars currently on spot in the industrial zone and their location and correct disposition.
3. Car orders to be filled by the conductor from the pool of cars made available to him by the car distributor.
4. A pull list, indicating the new spot location or "tag numbers" of the cars, so that he might switch the cars accordingly if this is local operating practice.
5. Any work order messages directed to him by the car distributor describing more fully the details of car movements to be performed in his zone.

Every car which the engine crew handles is represented on one of these lists. As the crew performs the various movements, the engine foreman will note his spots, pulls, re-spots and constructive placements on the lists. When he returns to the local yard, this list will be given to the ISC clerk, who will use the cards at the I/O console to enter this information into the TOPS System.

EXAMPLE 3: LARGE TERMINALS

Large terminals will be broken down into individual components and each component will be treated separately by the central processor as a separate responsibility/location area. Thus, within a given locality in the terminal, the clerk at an I/O unit will maintain records to cover only the operations in the immediate vicinity. Whenever cars are transferred to another operating area within the terminal, the central processor will treat the transfer movement as if it were a train between any other two yards on the system. For example:

1. The desk yardmaster, as a tramp engine dispatcher, would direct a crew to transfer a cut of cars from an initial yard location in the terminal to a final yard location. He would enter this information by the same procedure used by a train dispatcher indicating a "call".

2. The initial yard location would receive a request for a consist of the cars to be included in the transfer cut and the departure time of this crew from the local point.
3. After entry of the above, the desk yardmaster would receive a message indicating the departure information.
4. The terminating point in the terminal would receive an "advance consist" which would list the cars in a transfer cut and provide a punched card for each to be entered in its own local records. It would also receive a request for the arrival time which it would re-enter as soon as the information was available.
5. The desk yardmaster would receive a summary of the transfer which would indicate the arrival information.

If there is no desk yardmaster in another terminal, and a local yardmaster uses his own crew to transfer a cut of cars to another yard area, the clerk at the I/O unit in the local yardmaster's office can accomplish the above procedure more simply by directly entering the consist of the transfer cut behind a special pre-punched header card provided for that purpose. Since the procedures followed by a clerk in any portion of a large terminal assume the same proportions as at the less elaborate yards along the line, all of the standard procedures for entering train information, maintaining local records, industry service center operations, etc., will apply.

EXAMPLE 4: PROCEDURES FOR HOLD CARS

The central processor will assume that every car not on spot, or that has not previously been placed in "hold" status, is in active movement on the railroad, and that lack of entries within a certain length of time indicate either potential delays or incorrect reporting. To prevent a car from being included on a "delay list" a yard must place this car in a "hold" status, and indicate the reason for the hold and the responsibility/location area from whom release and next disposition is to be expected. This entry is made by utilizing the punched card maintained at the local I/O unit. Upon receipt of this information, the central processor lists the car in its "hold record", so that from time to time all cars being held on the railroad can be monitored. At the same time, if the reason for holding is such that a traffic office, car distributor, or other operating office is to be notified of the car's delay, the central processor will compile a message identifying the car and indicating the nature of the delay; this message would be issued to the I/O unit located most conveniently to the person who is to receive it.

It will be possible to place a hold on any car on SP lines by entering a code indicating hold into a convenient I/O unit and including the car identification, the yard to hold the car, and an indication of the reason for the hold. Upon receipt of such an entry, the central processor will check the authority for the hold request as follows:

1. For empty cars - If the request was received from the car distributor that has placed disposition on the empty car, or the responsibility/location area from which disposition is expected, the hold request will be automatically accepted. Otherwise, it will be directed to the car distributor for his approval.

2. For loaded cars - Upon request, the yardmaster who is to effect the hold will indicate whether the car can be captured and held; both the origin and destination traffic office will be notified of this.

Upon arrival at the point of holding, consists and switch lists on which the car is included will indicate hold status in lieu of the S. P. destination.

When release and new disposition is indicated to the central processor by the designated I/O unit, the car will be deleted from the hold record and a message will be compiled for the yard office that is holding the car. A message indicating the new disposition of the car will be received by the yard office with a new punched card to replace the "hold card" for the car in the yard office's records. For certain types of release from hold status, other personnel would be notified by a copy of the message, as follows:

1. For empty cars - the car distributor.
2. For loaded cars - the origin and terminating traffic offices.

When a car has been placed in hold status, any attempt by a yard office to enter a change in the car's location will cause the central processor to send a message indicating this condition to the responsibility/location area authorized to make release.

Situation and Turnover Report

Once per eight-hour shift, the central processor will check through all records as a regular part of maintaining its files. At the same time, it will compile a survey of the information and situation in its records. The portion of this survey pertaining to a particular major operating area will be printed out on the I/O unit located in the area. A summary of this survey for the division will be issued to the I/O unit in the dispatcher's office. A system-wide summary will be prepared for the car distributors and Superintendent of Transportation. The situation report will contain the following sections:

1. Count of cars moved, released, interchanged, etc., at the various yards on the system.
2. Count of cars currently in the major yards on the system, and along important sections of the line, summarized by "tag number".
3. Number of cars delayed at the various yards, with a detailed listing of the important delays.
4. Summary of cars currently placed in hold status.
5. Summary of trains, both for those that have terminated during the past shift, and for those currently in movement.
6. Identification of "data requests" or corrections requested by the central processor which have been outstanding from a particular I/O unit for an excessive length of time.

This information will not only serve as an aid in planning and checking out the operating procedures on a system - wide basis, but also serves as a method of highlighting trouble areas quickly.

INQUIRY ABILITY

It is planned to make selected information in the central processor's records available through an I/O unit by placing an "inquiry" into the system identifying the type of information required. Under favorable conditions, the response to some inquiries will come in seconds. For other less priority items, the central processor will respond when it is relatively free of other demands, or alternately include the data as an additional item on the regular reports. In all cases, the central processor will determine if the I/O unit making the inquiry is entitled to receive the information. The types of inquiries that can be made available will include the following:

1. Car location.
2. Waybill or waybill abstract for intermediate shipments.
3. Condensed movement history, on-coming junction or last commodity of a car.
4. Train location and estimated schedule.
5. Locomotive units, crew or consist of a train.
6. Cars placed in hold status by a particular responsibility/location area.
7. Request for a new card for local records.
8. One or more sections of the Situation and Turnover Report.
9. Request to prepare an interchange report for a particular carrier at a particular location.
10. Current track check from certain specific locations.

MAJOR YARD OFFICE OPERATIONS

The initial collection and recording of basic data needed by the railroad is intimately associated with the yard operations. As at present, this work will be accomplished manually. The subsequent data handling is a different matter, it involves the transcription of data onto a number of reports, the cross-checking of items to detect errors and missing items, and summarization into final reports and distribution. The procedures described below have been designed to have the central processor absorb as many of these latter functions as possible. Once data has been collected, it will be put in machine readable form and reported to the central processor immediately. As data is reported, the I/O unit simultaneously prepares a copy for local reference and for use by operating personnel.

Work Area

It is proposed to organize a compact work area in the yard office in which the I/O units and the basic yard office records will be maintained. The I/O units will be conveniently arranged around a console at which a single clerk will sit, and from which this clerk can effectively co-ordinate the collection and disbursement of information within the yard and local operating area. This clerk will be supported by additional clerks, when necessary, to whom he can delegate specific tasks.

Southern Pacific Company

The Input-Output Unit

The I/O unit for the yard office is shown in Figure 2-3. This unit is described in more detail in the Equipment Specifications Section of the report. Essentially, this unit consists of keyboard and printer, a card reader and a card printing and punching component. Information can be read into the central processor from cards and a complete list of such input is provided by the printer for a local record of the data input. Information received from the central processor will also be listed on the printer; the card print-punch mechanism will simultaneously prepare punched cards for local use if these are prescribed by the central processor for the particular type of data output. A continuous roll of blank paper will normally be positioned in the typewriter to prepare an original and several copies of every message going through the I/O unit. The back copy will be folded behind the typewriter unit and preserved as the local record of all inputs and outputs performed by the clerk at the I/O unit. The first few copies can be torn off after a message is complete and distributed to local operating and office personnel.

By reversing a switch on his console, the clerk at the I/O unit can disconnect his I/O unit from the central processor and use it independently for a number of local functions. Messages to local personnel can be typed as on a regular electric typewriter; notes can be added to reports received from the central processor before they are distributed. Cards can be read by the card reader to type a list of the information, or to prepare a new deck of cards. As with all transmissions to and from the central processor, the back copy in the printer will be retained as the local record; the front copies will be distributed in the operating area as required.

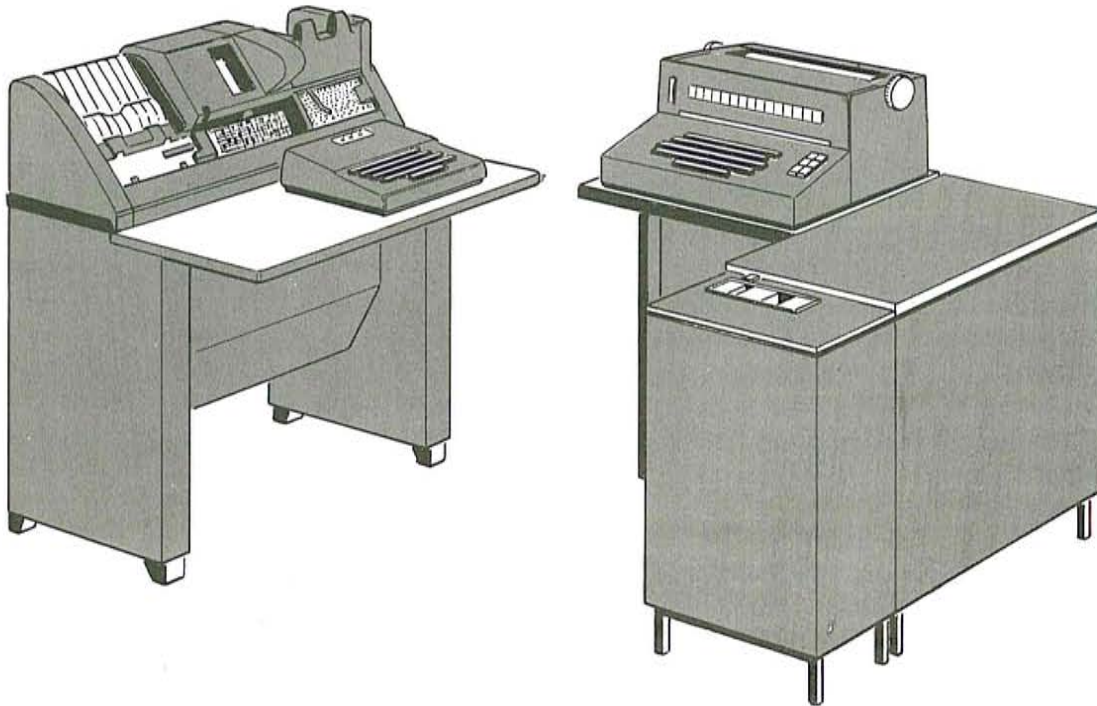

FIGURE 2-3 OPERATING I/O UNIT

IBM 10 Card Punch Unit

There will be many situations in which a clerk will wish to add a few digits of information to a card before entering it into the card reader or sorting it into other cards in his local records. The card can be inserted directly into the IBM 10 Card Punch and the digits can be keyed immediately without having to wait for the I/O unit card punch to be released by the central processor.

Telephones

Since the clerk at the console will be co-ordinating and collecting information from a number of data generating points and patrons, it will be desirable to equip the work area with several telephone lines. Moreover, the helper clerks should be able to answer calls on these lines from another yard office location when the I/O clerk is otherwise occupied.

Contact with Yardmaster

Of all local operating personnel, the yardmaster will normally make the greatest use of information in the records at the work area or from the central processor. For this reason, it will be desirable to make communication between the yardmaster's location and the work area, both verbal and printed, as convenient as possible. Most desirably, the yardmaster and work area would be located adjacent to one another to permit direct contact. When this is not feasible, a direct intercom connection, a remote writing device or pneumatic tube is considered desirable to avoid excessive distribution of lists by messenger, or delays involved in normal telephone communication.

Current and Historical Local Records

To facilitate the entry into the I/O unit, it will be desirable to replace some of the current records now handled in a yard office with a file of punched cards located in the work area. The exact nature of these records and their use will be explained more fully below. In general, however, as various cards in these files lose their current value to the yard office operation, they will be pulled from their file and used to enter information into the central processor. Once the I/O unit has successfully transmitted the data contained in the cards, most of them will be put in a dead card file since an exact record of the data will have been prepared on the printer during transmission.

When the card represents a legal document, however, it will be stacked in a separate box and stored as required. Cards retained in this historical file will normally not have to be sorted since all of the data they contain will also have been transmitted to the central processor and listed on the yard office record. When the exceptional situation arises in which one of these cards is needed for legal reasons, the appropriate boxes in the historical file can be located, transported to IBM punched card equipment and then sorted exactly as required.

Pre-punched Cards

To reduce the amount of card punching necessary to enter data into the I/O card reader, and also to avoid the problems arising from the errors inherent in such operations, maximum use will be made of pre-punched cards. Most types of data to be entered into the I/O unit will have been punched cards prepared by the central processor. Data can be punched into these cards for subsequent entry into the TOPS System. For other situations, a bin file of pre-punched cards will be maintained in the work area from which the appropriate type of card can be removed and used.

Clerical and Card Punch Support

Usually there will be one or more additional clerks who will support the clerk at the console. They will accomplish specific tasks delegated to them from time to time. Such tasks might include checks on certain inbound and outbound trains or transfer cuts, track checks in the yard or associated industrial area, and answering the telephone to accept releases and car orders from patrons. Supporting clerks will also be used to messenger lists and reports to various personnel in the yard area in order to collect data from them for input into the TOPS System.

An additional card punch will frequently be available in the yard office; with this a support clerk can punch into blank cards, or in cards provided him by the clerk at the console, data that has come from the interchange, inbound conductors or other local personnel. When such punching is completed, the cards will be given to the clerk at the I/O unit who will sort them and transmit the data to the central processor when appropriate.

Local Records In The Work Area

Records for Cars in Yard (Perpetual Inventory of Car Location File - PICL)

The central processor will print and punch a card for every car entering the yard; the yard will use this card for entry of consist information and certain other types of data. For local use, this card will contain description information about the car. A special identification code is included in the card by the central processor for its own use, and is of no interest to yard personnel. Sixteen columns of the card will be available for adding information about the car for subsequent re-entry into the central processor. Figure 2-4 shows the format which is followed for all cards produced by the central processor for local use. Whenever these cards are read into the card reader, the printer prepares a listing of car initial and number and types to the right of this any supplementary data that has been punched into the card. If the cards are read while the I/O unit is connected to the transmission line, the data will be sent to the central processor. If the card reader is not connected to the line, the printer prepares a listing of descriptive information for use locally. Once data has been punched into a card and it has been entered into the central processor (thereby changing a car's status) the card can be discarded. If the central processor requires further information about the car from the local yard, it will issue a new card for the car with updated information in the descriptive area, and with sixteen columns available for subsequent entry.

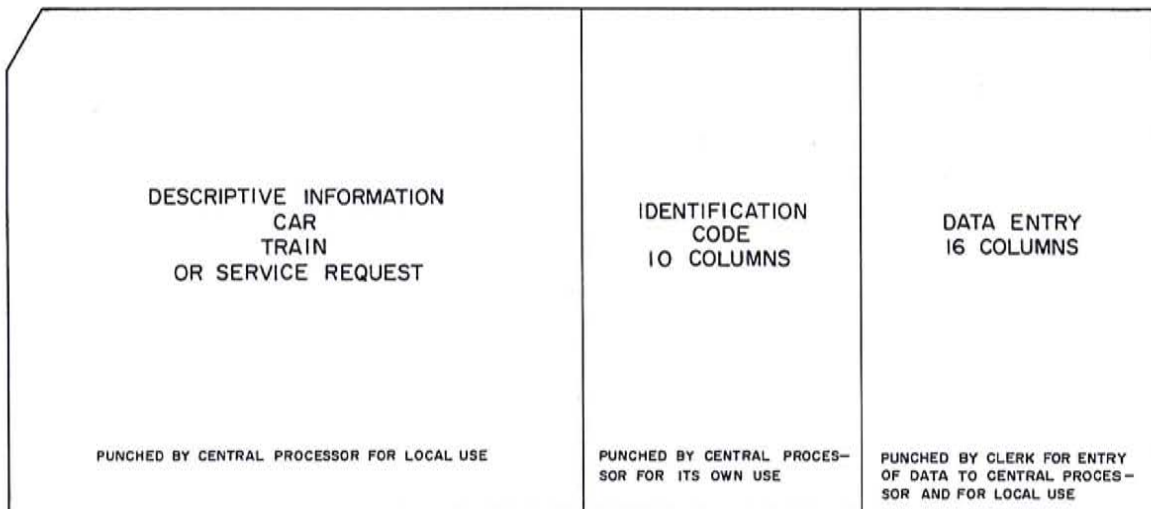

FIGURE 2-4 FORMAT FOR CARDS PRODUCED BY THE CENTRAL PROCESSOR FOR LOCAL USE

With his various files of punched card records, plus the ability to supplement these records with information from the central processor immediately upon inquiry, the clerk at the I/O console becomes the most important source of information for all local forces and patrons. In return for providing information quickly and in convenient form, the clerk will have to expect prompt reporting back to him of data which he requests for entry into the TOPS System or for relay to other operating forces.

It should be noted that there are several ways of maintaining the various types of records to be described. Each office will be analyzed, therefore, to develop the most efficient method of maintaining the records to conveniently provide the desired information in that locality. The approach will be to arrange the various files of cards in a manner that will provide maximum benefit for local personnel, and still keep the cards convenient for subsequent data entry. Desirable filing techniques will be mentioned below as the various types of local records are discussed.

The clerk will maintain, in the most convenient way, a file of the cards produced by the central processor when the cars enter the yard. This file represents a perpetual inventory of the cars on hand in the yard. The recommended manner for keeping the file is not basically different from the procedures some yards now follow with waybills. In fact, it is currently in use in several yards on the S. P. System and being extended to others. This method, called the Perpetual Inventory of Car Location (PICL), maintains the file so that it reflects the current location of any car in the train yard at any time. The technique is to sort the cards into a rack that has a separate box assigned to every track in the train yard, and maintain the cards in each box in the same order in which the cars are standing on the corresponding track in the train yard. With the cards so organized, the clerk at the console can, when requested by the yardmaster, remove the cards from a specific box, place them in the card reader and automatically prepare on the printer a current track check or switch list in a matter of several minutes. An example of a Track Check List is shown in Figure 2-5.

```

TRACK HEADER EUGENE  19 E W

UTLX 10690 T E 32 GRADE      0376 275
SP 561858 F5 E 19 GRADE      EUGENE YD   HOLD FOR YM
TNO 55427 BH L 65 PLYWOOD    SPRINGFLD  GEORGIAPACIFCO
GTW 516438 BL L 43 CANS      COOS BAY   EXPEDITE
SP 680650 AR L 35 AUTOMOBLS  FAIRVWJCT
CBQ 46596 B5 E 30 GRADE      MYRTLE PT  HOT CAR DBR
CNW 9417 FB L 56 PLASTBRD    ALBANY     DIVERSION
    
```

EXPLANATION OF ABBREVIATIONS

1st. LINE - Track 19 Listed From East to West.
 2nd. LINE - 32 (Gross Weight) 0376 275 (Destination Spur and Spot No.)

FIGURE 2-5 TRACK CHECK LIST

To maintain the file in correct track order as switching is performed, the yardmaster must ascertain the work currently being performed by his switch crews, and transmit this information to the clerk maintaining the inventory records. In this way the clerk can switch his cards in the inventory boxes exactly as the cars are switched in the yard. To accomplish this, the yardmaster can use any of a variety of methods. The most common of these are:

1. Mark a switch list with track numbers and cuts to be made by the engine foreman. Give one copy to the engine foreman and one to the clerk maintaining the inventory. If the foreman performs the work at all differently, he must indicate the exceptions to the yardmaster who, in turn, notes these to the inventory clerk.
2. Make a number of switch lists available to the engine foreman. He should note the tracks on which he is switching cars and where he has made his cuts, then refer this information back to the clerk. When he cannot report back conveniently, the clerk can send a support clerk out to recheck the tracks switched, and relay the information back to re-establish the inventory file.

The engine foremen must be made to depend upon the yardmaster for closer co-ordination of their moves so that they will report to the yardmaster as expected. Thus, with such a system, tags physically placed on cars will no longer be necessary or desirable. When an engine foreman must know data about a track he is to switch, the yardmaster can get this information from the clerk at the console and relay it to the field as quickly as a pull-by check could normally be made by the foreman's crew. At the same time, the yardmaster can keep close contact with the engine foreman's moves as he passes out the data. Since engine foremen have only that data necessary to do specific tasks as assigned, they must depend on yardmaster to plan and indicate the exact nature of their work, rather than switch entirely on their own initiative.

This method of filing cards for cars in the train yard, therefore, provides not only a convenient way for the yardmaster to find out the current picture in any part or in his whole yard at any time, but also places him in a position to more

carefully plan the direct activity of his crews. At the same time, the PICL file provides convenient way for the clerk at the console to locate cars in the yard when necessary, and to enter data into the card reader with a minimum of card handling.

Interchange Received

When a cut of cars has been received on an interchange track it is the clerk's responsibility to transmit the interchange data to the central processor. This data consists of:

1. Delivering carrier - on header card.
2. Interchange point - on header card.
3. Station number - on header card.
4. Time of interchange - on header card.
5. Operating data about each car - punched onto blank card.

The clerk will select from a bin a pre-punched Interchange Header Card which contains the first three types of data. He will punch the time and date of interchange into the Interchange Header Card.

The operating data that must be entered for each car is:

1. Car Initial and Number.
2. Type of car.
3. Load or empty.
4. Contents.
5. Gross Weight.
6. Consignee (if switch move).
7. S. P. destination (if road haul) and connecting carrier code.
8. Ultimate destination (if empty moving on W/B).
9. Special operating instructions.

The clerk will punch this data into blank cards and place these cards behind the Interchange Header Card. The cards will then be put into the card reader and the data will be transmitted to the central processor; at the same time, a local listing will be made. The central processor will respond to this transmission by issuing cards to the yard for the cars in the interchange.

The documents used by the clerk to obtain the required information will be the waybills and switch bills, if available. If these are not available, then the clerk will use transfer lists, verbal contact with the connecting carrier or other means, according to local operating procedures.

When the connecting carrier delivers the interchange report the clerk will verify it with his local listings, then mail it to the general office.

Interchange Delivered

When the clerk is informed that a cut of cars is to be interchanged, he will remove their yard cards from his PICL file and place them behind a pre-punched Interchange Header Card indicating the interchange. This deck is then placed in the card reader and, as it is transmitted to the central processor, a list is produced with which the waybills can be pulled. The central processor will respond by typing out a transfer list containing the final destination, consignee and an indication as to whether the car originated in a S. P. switch or road move. The clerk will send two copies of the list, and the waybills, to the interchange.

After the interchange is completed, one copy of the transfer list will be returned to the clerk at the console, with the time of interchange noted, together with any additions or deletions to the list. The clerk will pull the cards for the cars to be added or deleted from his PICL file, and punch a code in each indicating which condition exists. Then, he will take the Interchange Header Card, add the time of interchange, place it in front of the additions and deletions (if any), place this in the card reader and enter it into TOPS System. All yard cards for cars delivered are then placed in the discard box. The central processor will re-issue a new yard card for any cars deleted from the interchange list in order to replace them in the PICL file.

Interchange Report - Whenever local interchange procedures will permit, all interchange reports will be prepared centrally and mailed to the connecting carrier. When an interchange report must be prepared locally, a clerk, once a day, will request the central processor to prepare an Interchange Report for the cars interchanged with each road during the last 24 hours. After he has put an interchange report form into his printer, the request will be made by inserting an Interchange Report Request Card in the card reader and transmitting it to the central processor. The central processor will issue a report for each connecting carrier at that junction. If one or more connecting carriers did not receive cars on interchange, then the interchange report will read "No cars interchanged".

Bad Orders in Yards

Whenever a Car Inspector detects a bad order in the yard, he will relay this information to the clerk at the console. The clerk will immediately pull the card for the car from the PICL file, add a code indicating "bad order", and transmit the information to the central processor. The card will then be replaced in the PICL file. On subsequently prepared switch lists, this car will be indicated as "bad order" by a code symbol printed out on the listing.

Service Tracks

The clerk's PICL file will contain bins for cleaning tracks, rip tracks and for the shop area. After cars are switched into these areas, the clerk will pull the cards from the corresponding bins with an identifying track header card, put them into the card reader and transmit the data to the central processor. The central processor will recognize that the yard cards behind the rip track header card represent cars that are on the rip track and will update each car's status with this information. The central processor will react similarly for yard cards behind the cleaning track and shop area header cards. In this manner, the central processor will be able to keep its records current as to the status of cars.

Assigning a "Hold" Status to a Car

A car may be put into a "hold" status by anyone who has authority over that car, even if that person is remote from the car. If the person is remote, the request to hold a car will be handled by the central processor which will issue, to the yard that has the car, a "hold" request message and a new yard card with the status of the car shown as "hold". The clerk will first ascertain from his PICL file and the yard-master that the car can be held. If the car can be held, he will replace the old yard card in his PICL file with the new card, enter the old card into the TOPS System, and then discard it. If he cannot hold the car, he re-enters and discards the new card. The central processor will know from the type of entry whether the car is being held or not.

When someone in the yard that has the car wishes to put the car in a "hold" status, the clerk will simply find the yard card for that car, punch into it the "hold" code indicating the reason for hold, and put it into the card reader. The data will be transmitted to the central processor which will respond by issuing to the yard a new yard card which will replace the old card and indicate the "hold" status.

The same procedures will be used to release a car from a hold status. When released locally, a "hold release" code will be punched into the "hold" card in the PICL file together with the new disposition; the central processor will respond by issuing a new PICL card incorporating the new disposition. When the release originates from a remote point, the yard will receive a new card containing the new disposition. The new card will replace the old one in the PICL file.

Cars on Spot (Industrial Service Center - ISC)

Industrial areas associated with major operating points will be divided into Zones, the boundaries of which correspond to those of the regular switch engine assignments that service the areas. These Zones will be numbered; the spurs within a Zone will also be numbered such that the first digits of a spur number will reflect the Zone in which it lies.

When cars are moved from the train yard to spot, the cards at the console for these cars will be removed from the PICL file and replaced in another file reflecting the car's location in an Industrial Zone. This Industrial Zone file will consist,

Southern Pacific Company

basically, of a deck of pre-punched header cards with one card for each spur in the Zone. The PICL cards for the cars on spot will be sorted behind the appropriate spur header cards so that, should this entire file be placed in the card reader, the listing produced would be a current track check of the Industrial Zone. The availability of this track check should eliminate, or at least reduce, the amount of time now spent in ground checking industrial areas since the clerk at the console should be able to keep the file up-to-date, as well as perform the work described in the following procedures.

The cards in the ISC file will be used to read into the TOPS System types of information which are distinctly different from those in the PICL file; thus, the ISC file, although still reflecting car location in the area, will be kept entirely separate in the work area. The cards will be stored in a card tray rather than a card rack; a separate tray will be maintained for each Industrial Zone. Occasionally, these trays may be transported to a support clerk's desk so that information, such as releases, can be received from patrons and noted directly on the cards without placing too heavy a work burden on the console clerk.

Releases

The patron will contact the ISC clerk to release a car. The clerk will write down the release data which should include Car Initial and Number, destination district, special instructions and commodity for loads, and only special instructions, if any, for empties. The clerk will also note the release time. The clerk will punch into the yard card that represents the released car, the release code (empty load, etc.), release time, S. P. district and coded special instructions if the car is loaded. If the car is empty, only release time, release code and special instructions will be punched. The data will be transmitted to the central processor and the yard card will be replaced in the ISC file.

If a loaded car is released for transfer to a local interchange track for switch-to-switch movement, a blank card will be punched with the consignee's name; this blank card will be placed behind the yard card for entry into the card reader. This entry is necessary in order to provide the name of the consignee on interchange delivered reports for switch-to-switch movements.

Recording Car Orders

Car orders will be received by the ISC clerk either from patrons or agents along the line. An agent's order may be a specific order (placed by a shipper) or a "blanket order" (naming himself as shipper) which represents the cars he feels he needs to fill local orders. The following procedures are based upon a two part, printed, pre-carbonized card order form set which consists of an IBM card and an identically sized paper form attached at one end and separated by a piece of carbon paper. This form will contain the information recorded on the present car order form. An example of the card is shown in Figure 2-6. The card contains a car order number which will be both punched and printed during manufacture. The ISC clerk will write the car order information on this form set while conversing with the patron or agent on the phone. For each different type of car and commodity, the clerk will make out a separate order form and thus create separate car orders. After he has

Southern Pacific Company

received an order, the clerk will enter the card in the card punch and, reading from the paper copy, he will punch selected information as indicated by the number boxes on the form. Each box will be punched in sequence with a special character inserted after each one. After the cards are punched, they will be entered into the central processor and filed by spur and spot number in the ISC's "orders outstanding" file.

| | | | | | | | | | | | | | |
|------------------------------------|--|-------------|--|---------------------|--|--|--|--|--|--------------|--|---------------------|--|
| STATION OR AGENCY | | | | TIME AND DATE FILED | | | | PREPCHD NO. | | SP ORDER NO. | | SHIPPER'S ORDER NO. | |
| 1. SPUR NO. | | 2. SPOT NO. | | 5. NUMBER WANTED | | R 1 | | REPETITIVE CAR ORDER NO. | | | | R 2 | |
| 3. DATE WANTED | | | | R 3 | | 6. KIND | | 7. CAPAC (CU) | | 8. COMMODITY | | | |
| 4. SHIPPER | | | | | | DESTINATION | | | | 9. AREA CODE | | R 4 | |
| SHIPPER'S ADDRESS AND/OR PHONE NO. | | | | | | CONSIGNEE | | | | 10. ROUTE | | R 5 | |
| CARS PLACED TO FILL ABOVE ORDER | | | | | | 11. REMARKS - SPECIAL INSTRUCT, LENGTH, ALTERNATE KIND, CAP (LBS.) | | | | | | | |
| INITIAL | | NUMBER | | DATE | | TIME | | COPY OF ORDER MAILED TO | | | | DATE | |
| | | | | | | | | SIGNATURE OR INITIAL OF PARTY ORDERING | | | | | |
| | | | | | | | | | | | | | |
| | | | | | | | | | | | | | |

FIGURE 2-6 CAR ORDER FORM

Repetitive Car Orders

A "repetitive car order" in the TOPS System is defined as an order placed repeatedly by a shipper. These orders are similar in all respects except for certain variable data: date and time wanted, number of cars wanted, destination and route. Each "repetitive car order" will be assigned a "repetitive car order number" and an ISC clerk will be supplied with a list of repetitive car orders for his territory. The patrons will be given this information for their repetitive orders. When the patron phones in a repetitive order, he may simply give the "repetitive car order number" and the variable data. The ISC clerk will write the "repetitive number", obtained from the patron on the list, on a car order form. Only this number and the variable data, e.g., the boxes marked "R" on the form, will be punched. When the card is read into the TOPS System, the central processor will complete the car order automatically.

Cancelling Orders

When a patron cancels a car order, the ISC clerk will pull the order card out of his "order outstanding" file, place it behind a "cancel order" header card, and read both into the central processor.

If a car had been prescribed for the cancelled order but not yet moved, the yard card will be read in behind the "cancel order" card and the order card. The central processor will output a new card, which will replace the old one in the ISC file. If the car has already been moved, a new card will be sent to the appropriate yard to re-direct the car.

Southern Pacific Company

Prescribing a Car

When the car distributor has prescribed a car to fill an order, the destination will be included on a new yard card issued by the central processor, to replace the old yard in the ISC or PICL file. When the car is prescribed locally according to instructions from the car distributor, the ISC clerk will punch the spur and spot number in the car's yard card. He will then place the yard card behind the car order card and enter them into the TOPS System. Finally, the car initials and numbers of the cars prescribed are noted on the order cards and all the cards are returned to their respective files.

Setting Up and Deleting Repetitive Car Orders

A new repetitive car order can be established by entering the car order card behind a "repetitive car order" header card. The central processor will assign a repetitive car order number and transmit this to the ISC clerk who will add it to his list of current repetitive car orders.

The central processor will check the usage of each repetitive order, periodically, and if an order is not utilized sufficiently, a message will be sent to the ISC clerk. If the ISC clerk wants to delete this car order from the repetitive classification, he will simply punch the repetitive car order number into a car order card. Then he will read this card into the central processor behind a "delete repetitive car order" header card.

Spot and Pull Lists

When the yardmaster indicates that a switcher is going into a zone with a cut of cars from a particular track in the local yard, the clerk will pull the yard cards for that track from his PICL file. He will make a listing of these cards which will be a Spot list. These cards will then be filed in the ISC file. The clerk will then take the cards from the ISC file for cars currently on spot in the zone and place them in the card reader in order to add a current Track Check of the zone to the Spot list.

The clerk will also take from the zone file all the order cards for car orders for which no car has been prescribed, and which this crew is to fill in the field. He will read these order cards into the central processor behind a pre-punched List Orders - and - Release header card. The central processor will respond by typing out the detailed car order information for the orders indicated by the cards, and add a Pull list for cars released. This Pull list will include destinations specified by the patron or dispositions indicated by the car distributor. Many of the empty cars will be made available for local placement; others will be restricted for use elsewhere.

In the listings, those empty cars that have been prescribed for particular placement will have the spur and spot numbers indicated as destination. All other empties will have no destination indicated; the conductor will match the kinds and classifications of these empties with the requirements on his list of outstanding car orders, and spot them accordingly.

These listings will then be given to the conductor or engine foreman. An example of how the information would appear on the Spot and Pull Lists is shown in Figure 2-7.

Confirmation of Spots and Pulls

When the crew returns to the yard after working an industrial zone, they will return to the ISC clerk all the lists with the work that they have performed noted on them.

For any cars spotted, pulled or re-spotted and for car orders filled, the ISC clerk will pull the corresponding card from the ISC file and punch the information concerning work performed into the card. For cars spotted or constructively placed, he will punch a code indicating this condition, the spur and spot number and time. For cars pulled, he will punch information relating whether the car has been pulled loaded or empty. For cars re-spotted, he will punch the new spot location and time of spotting, and a code indicating why the car was re-spotted. Cards for cars spotted by the conductor or foreman to fill an order on his list will be sorted behind the corresponding car order card. The cards for the cars pulled will be placed behind a Pull header card which will contain the time the foreman arrived back at the ISC. The remaining cards will be placed behind these cards and the entire deck will be entered into the TOPS System.

The processor will respond by punching a new yard card for every car pulled or re-spotted, and incorporating any new information in the new cards. These new cards will be sorted into the PICL or ISC files according to their new locations.

The initial and number of the car used to fill the order will be noted on each Car Order Card. Those orders completely filled will be filed for future reference. Those not yet complete filled will be placed back in the ISC file as outstanding orders. If any orders are not confirmed as filled by the "time wanted", a message will be transmitted to the ISC clerk reminding him of the order.

Advance Arrival Notices

Whenever a load is received at interchange or originates on-line and is destined for a point on the S. P. System, an Advance Arrival Notice can be sent to the destination yard. An Advance Arrival Notice is simply a message stating the Car Initial and Number, commodity, consignee, time and origin station or interchange station. The message will be received on the printer at the destination yard, together with a card with the same descriptive information.

The anticipated advantage of this notice is that the spotting information can be determined far in advance of the car's arrival. This would aid the local personnel in two ways. First, the punching of spur and spot numbers can be distributed over a longer time. Secondly, loads which would normally be put into a "hold" status until spotting information is available would be reduced to a minimum.

| SPOT PULL LIST | | EXPLANATION OF ABBREVIATIONS | |
|---|--|------------------------------|--|
| EUGENE 0145P 01/14 | | Yard, Time, Date | |
| *****TRACK CHECK EUGENE TRACK J3 EAST TO WES | | | |
| ATSF 16346 BL L 94 CANND GDS 0849 013 | | | |
| REXX 1825 R E 31 GRADE ICE DECK | | | |
| TSF 9570 S L 54 CATTLE 0812 041 | | | |
| TNO 53772 BH E 22 GRADE 0803 027 | | | |
| SP 30562 BL E 22 GRADE | | | |
| SP 111135 B4 E 26 GRADE | | | |
| SP 30858 BL E 29 GRADE | | | |
| SP 329001 GC E 30 GRADE | | | |
| *****ZONE CHECK EUGENE ZONE 08 | | | |
| **SPUR 825 WESTERN PLYWOOD | | | |
| NKP 16139 BH L 61 VENEER 0825 077 | | | |
| SP 680697 AR E 28 GRADE 0825 012 | | | |
| **SPUR 832 SPOTS 30 TO 35 ACME LEATHER | | | |
| ITC 6303 BH L 36 HIDES 0832 033 | | | |
| **SPUR 843 SPOTS 60 TO 75 GEORGIA PACIFIC LUMBER CO | | | |
| MOPX 2291 DF L 42 PLYWOOD 0843 067 | | | |
| MILW 26451 BH E 25 GRADE 0843 072 | | | |
| **SPUR 850 ACTOFER BROS | | | |
| LN 99067 B5 E 29 GRADE 0850 028 | | | |
| EJE 61240 S L 49 CATTLE 0850 041 | | | |
| **SPUR 857 WEST ST TEAM TRACK | | | |
| SP 102632 BH E 28 GRADE 0857 007 | | | |
| **SPUR 858 WEST STREET TEAM TRACK | | | |
| ERIE 98564 B4 L 64 GLUE 0858 003 | | | |
| SP 680177 AR E 27 GRADE 0858 010 | | | |
| *****CONDUCTORS CAR ORDERS | | | |
| 0843 073 01 14 GEORGIAPACIFC 1 B4 PLYWOOD 16 | | | |
| 0813 043 01 14 US TANNERY CO 1 BL HIDES SP | | | |
| 0845 013 01 14 SAFEMAY 1 BL GROCERIES SP | | | |
| 0828 043 01 14 U S GYPSUM CO 1 GC 130 GYPSUM 16 | | | |
| *****PULL LIST EUGENE ZONE 08 - 01 45P 01/14 | | | |
| SP 680697 AR E 28 GRADE 0842 029 | | | |
| LN 99067 B5 E 29 GRADE 0810 028 | | | |
| ERIE 98564 B4 L 64 GLUE 0843 003 | | | |

FIGURE 2-7 SPOT AND PULL LIST

In many yards these factors would not be significant and the Advance Arrival Notices may actually cause an additional burden upon the local personnel. For this reason, Advance Arrival Notices would be sent only to selected yards.

When an Advance Arrival Notice is received in the yard, the clerk will determine the spur and spot number for that car and punch it into the card issued with the Advance Arrival Notice. The card will be put into the card reader and the data will be transmitted to the central processor. When the car arrives in the yard, its yard card, which is issued with the advance consist, will then have the spur and spot number already punched in it.

Diversions

After the central processor receives a diversion request message, a new yard card will be sent to the yard selected as the diversion point. The diversion message and card will be included on the advance consist if this is possible. Otherwise, it will be sent separately.

Upon receipt of the diversion message, the clerk will inform the yardmaster of the car initial and number, where it is in the yard, or what train it is on. When the yardmaster indicates that the diversion has been accomplished, the clerk will first write the new data on the movement document for that car and then put the new yard card in the card reader and transmit the data to the central processor. This signifies that the diversion has been accomplished. The new card will be inserted in his PICL file in place of the old one, and the old card will be discarded. If the yardmaster indicates that he cannot accomplish the diversion, the clerk will put the old yard card in the card reader and transmit the data to the central processor signifying that the diversion cannot be accomplished. The new yard card will then be discarded and the old one will be placed back in the PICL.

Data Items Needed by the Central Processor

When the central processor needs items of information to fill out its records, it will issue "data request" cards which clearly indicate the required data. Such cards also contain some special identification codes used by the central processor for its own purposes, and sixteen columns into which certain requested data can be punched. When "data requests" are received, the console clerk should initiate the procedure described below to get the data into the TOPS System. Meanwhile, until the data has been read into the card reader, the "data request" cards will be sorted into a small file with other similar requests. This file will probably occupy several of the bottom boxes in the PICL file card rack so that the clerk at the console can continually monitor the number and types of data to be collected. When the requested data has been obtained and punched by the console clerk, or his support clerk, the appropriate "data request" card will be pulled from the file and used to identify the information entered into the TOPS System. Once transmitted, these cards can be discarded along with most of the detail data cards that were used to enter the information itself.

Crew Data Request Card

The clerk will contact the crew dispatcher, from time to time, for the on or off duty times of various crews, the man numbers of the members of the crews and any claim that might be filed. For each man, the clerk will punch into crew cards, the on or off duty time and a code for claims. These cards will be placed behind the appropriate Crew Data Request Card; they will then be entered into the card reader and the data will be transmitted to the central processor. Finally, the cards are placed into the dead card file.

Locomotive Data Request Card

To complete the locomotive data the clerk must contact the mechanical department and ascertain what locomotives are going out on what train, the order in which the locomotives will be on the trains, the status of each locomotive (helper, dead, etc.) and the set out point if a locomotive is not going through to the terminating yard.

The engine data will be punched into locomotive cards. These cards will be placed behind the Locomotive Data Request Card and put into the card reader for transmission to the central processor.

At the terminating yard, the data entry that will be required for locomotives arriving will be the confirmation of a predicted run, the numbers of the locomotives that might have been set out, and the set out points. The data will be entered in the same manner as described above.

Arrival or Departure Time Request Cards

For arrival or departure time, the clerk will determine the arrival or departure times of trains and will punch this data into the arrival data or departure data request card for the appropriate train and transmit the data to the central processor.

Consist Data Request Card

When the clerk is informed that a train is made up, he will take the yard cards from his PICL file, put these cards into the card reader, and produce an off-line listing of the cards. The listing will be the conductor's train list. On it, the clerk will manually total the number of cars and tonnage. The list will also be used to pull the movement documents for cars in the train. One copy of this list will be used to make a check of the train. When the check has been completed, the clerk can manually correct any errors in the train list. Then, the train list, movement documents and blank pickup/setout card sets, where necessary, will be given to the conductor.

The clerk will then prepare to transmit the advance consist to the central processor. If there were any changes to the train list, the clerk will make the same changes to the cards that were used to make the train list. The clerk will also define

the blocks within the train by means of pre-punched block cards. For adjacent cars that have a common setout point, the clerk will insert the pre-punched block card for that setout point immediately in front of the consist cards representing cars in this block. The clerk will do this for every block in the train. The deck of cards will then be put behind the Consist Data Request Card and placed in the card reader. The central processor will recognize this as the advance consist.

Inbound Trains and Work Enroute Data Request Card

Before a train arrives in a yard, the central processor will issue the Data Request Cards already mentioned, an advance consist and yard cards, and the work enroute data request cards. If this yard is not the terminating yard, the advance consist will be in block form; that is, there will be one line for every block in the train, with the exception of the block which is to be set out at this yard. A block card will be issued corresponding to each block along with the yard cards for the cars to be set out.

For a car that is to be set out at this yard, the record on the advance consist will contain either the spur and spot number or the consignee's name, in addition to the car initial and number and the normal consist data. For single cars destined beyond this yard there will be only one line per car on the advance consist, which will have the normal consist information. Figure 2-8 illustrates how this information may appear on an advance consist.

Block Breakup - If cars in a block are not scheduled to be set out at a particular yard, but must for any reason be set out at that yard, yard cards must be issued to the clerk. To obtain these yard cards, the clerk will use the block card representing the block that contains the car. The clerk will put this card into the card reader and transmit the data to the central processor. The central processor will respond by issuing yard cards for the block to the yard. To reform the block, the clerk will put the yard cards behind the block header card and enter the data into the system with the consist for that train. If only one car in the block is setout, the clerk will punch the initial and number of the car into the block card and enter it into the TOPS System. The central processor will respond with the yard card for the car and a new block card.

Work Enroute Data Request Card - When the train arrives in the yard, the conductor will deliver to the clerk his train list, movement documents and Pickup/Setout cards. The clerk will sort the Pickup/Setout cards according to the following rules:

1. Set aside all the setout cards that were prepared by a PICL clerk on his I/O unit, as indicated by the color of the card.
2. Behind these, place all other setout cards; either the corresponding yard card (if it was an unplanned setout) or the pickup card (if the car was picked up enroute) will have been sorted in front of the other setout cards. The yard cards will have been issued with the advance consist.
3. At the rear of the pack, place all other pickup cards.

EXPLANATION OF ABBREVIATIONS

Train Departure Yard Time Date - Arrival Information
Locomotive Unit Numbers

Loads/Empties/Tonnage Setout at

Hold for Yard Master (Special Instructions)

Data Requests

NOTE: This illustration is a 25% reduction
of the actual report size.

CONSIST 5644-LV 2319 0643-01/14 - EST AR 2256 1500-01/14
LOCO 5664 6168 6160
CREW PAULSEY W A, NICKS A B, SMITH D J,
ADAMS O K, CYERT B S

BLOCK - SP 34376 TO CNW 123476 - 46/13/2512 SO 2205

BLOCK - TNO 1289 TO NYC 77341 - 05/04/0491 SO 2096

BLOCK - ATSF231905 TO SP 221570 - 02/07/0317 SO 2005

BLOCK - UTLX 10690 TO TNO 55427 01/02/0117 SO 2256

UTLX 10690 T E 32 GRADE 0376 275

SP 561858 F5 E 19 GRADE EUGENE YD HOLD FOR YM

TNO 55427 BH L 65 PLYWOOD SPRINGFLD GEORGIAPACIFCO

BLOCK - GTW 516438 TO CNW 9417 03/01/0164 SI 2256

GTW 516438 BL L 43 CANS COOS BAY EXPEDITE

SP 680650 AR L 35 AUTOMOBLS FAIRVWJCT

CBQ 46596 B5 E 30 GRADE MYRTLE PT HOT CAR DBR

CNW 9417 FB L 56 PLASTRBRD ALBANY DIVERSTON

SP 876 L CREW EUGENE YD

MESSAGES

CNW 9417 FB L DIVERSTON CHANGE WAYBILL
CONSIGN JF DUPREE TO BJ MUTH
ROUTE SP TO SP UP
DESTIN ALBANY TO OMAHA

DATA REQ - CREW X5664 - LV 2096 01/14
DATA REQ - LOCO X5664 - LV 2096 01/14
DATA REQ - CNST X5664 - LV 2096 01/14
DATA REQ - DEPR X5664 - LV 2096 01/14

FIGURE 2-8 ADVANCE CONSIST

The clerk will then punch into these cards the data written on them. He will place them behind the Work Enroute Data Request Card and transmit the data to the central processor.

Generating Pickup-Setout Cards

When a train arrives at its terminating yard, the clerk will check the conductor's train list and movement documents for cars that will be leaving on other trains which will be set out at a local point not equipped with an I/O unit. For each of these cars, the clerk will prepare a Pickup/Setout card set using the yard cards. The clerk will put the yard card for those cars into the card reader. For each yard card there will be two cards reproduced on the printing card punch. The card stock used will have pre-punched codes and alternating colors. The code and the color will identify the card as being a Pickup or a Setout card. The two-card set will then be put in the fold of its associated waybill.

Terminating Loads and Prescribed Empties

When loads and empties are terminated at a yard, it is the responsibility of the PICL clerk to punch the spur and spot numbers in the yard cards, if this information is not already in the card. He will determine the spur and spot number by using the name of the consignee shown on the consist. After this is done, the clerk will file the yard cards in his PICL file.

Service Data Request Card

In addition to the advance consist, the yard will also be issued Service Data Request Cards for cars that are to be serviced in that yard or that have been serviced while on the train. These cards will be used to enter the data concerning the service. Exactly how the data is obtained depends upon which procedure is most convenient at each yard. In some yards, the Service Data Request Cards will be sent to the area or personnel who will perform the service. The cards will then be sent back to the clerk with a description of the service noted on the card. The clerk will then punch the data into the card and transmit it to the central processor. In other yards, the cards may be kept with the clerk, who would be responsible for gathering the data by telephone or by receiving marked lists.

The conductor will have noted on his train list the service he performed on cars in his train. The clerk will use this document to punch and enter the servicing data into the central processor.

If services were performed on a car for which no Service Data Request Cards have been issued, the clerk will punch into the consist card the location which performed the service, a code indicating the type of data (namely servicing) and the nature of the service.

Situation and Turnover Report

The central processor will compile, as part of its regular processing, reports to local personnel. This may be an advance consist, a message describing what appears to be an error in some data received from the I/O unit, or a Situation and Turnover Report. The Situation and Turnover Report (See Figure 2-9) will be provided once per shift and will indicate the following:

1. Count of cars moved during last shift - Into or out of yards, to and from interchanges or spot, off cleaning tracks, etc. This is a type of performance report that can be used to review the operations in the yard area.
2. Count of cars currently in yard - Summarized by "tag number", number of cars on spot, number of cars released but not pulled, etc., (this can be amplified with a yard check by the clerk handling the PICL file). This provides a picture of the current situation.
3. Cars delayed - By applying different time standards to different "tag numbers", the central processor will list or summarize the cars for which it has not received information within a particular period of time. This will indicate to local personnel either a potential delay or a car reported out on a train incorrectly. Once the car is located, the clerk at the console can notify either the yardmaster or the central processor, as appropriate.
4. Cars in hold status - In the responsibility/location area, either for filling empty car orders or for credit clearance. This will serve as a memorandum to local personnel about cars for which they are responsible to report disposition.
5. Summary of dispatcher's calls and estimated schedules - This is, essentially, a line-up of trains to, from or through the local yard area.
6. "Data Requests" outstanding - This is a list, or summary, of the types of data for which the central processor is currently holding the local clerk at the console responsible. For each item, the clerk will have a Data Request Card in his local records and can check these to make sure none are missing. This section will also spotlight those data requests which have been outstanding beyond some standard length of time.

Copies of this Situation and Turnover Report will be removed from the I/O printer and distributed to the yardmaster, train master and other local personnel; they will also be retained by the clerk at the console for his reference. Basically, the report summarizes the data contained in the central processor that is of interest to local personnel.

Inquiry Ability at a Major Yard Office I/O Unit

When local records are insufficient to provide current data that is required, the clerk at the console will be able to enter an inquiry into his I/O unit by punching a card with a code indicating the type of information wanted, and the car or train

SITUATION & TURNOVER REPORT
EUGENE 0825 07/10

CARS MOVED LAST SHIFT
NO IN 46779/4302 - 3 TRNS OUT 149/177497-2 TRNS
SO IN 00/147/3300-2 TRNS OUT 149/177497-1 TRN
EA IN 12/02/651-1 TRN

Z04 FROM 5/11 TO 16/7 ORD FILLD-7 OPN-13B5
Z08 FROM 2/4 TO 03/30 ORD FILLD-30 OPN-0
CLN FROM 1485 6DF TO 3384 1DF 4F
WEIGHED-139/42

CARS ON HAND 284/201
TAG 03-0/-7 04-14/7 07 6/12 08-18/2
TAG 19-46/27 43-35/1 47-12/82 49-136/14
T TAG 62-3/45 71-14/4
HOLD-DBR 14684 7285 358L 16DF 1F5 13G5
AGT 1 LD
AVAILABLE FOR LOCAL ORDERS 1385 6B4 4G5
REL-ON SPOT Z03-2/1 Z07-3/0 Z08-0/1
WEIGH 42/12

DELAYS OVER SID
TAG 03- 16HR-0/7 07- 16HR-0/1
TAG 19- 08HR-30/12.16HR-0/12.39HR-0/08
TAG 47- 08HR-5/0
TAG 71- 16HR-3/1 ATSF SP 1005.SP 325478
REL-ON SPOT- Z08-48HR-0/1 SP 905641

LINE UP-IN
NORTH X2345 46/170-PAB04.CC806 EAR 1245
X4632 33/12 -PB806 EAR 1415 REV
SOUTH X1043 10/135-MTY DRAG EAR 1400
LINE UP - OUT
NORTH CD4 - 6500 TONS - 4 UNITS EDPR 1045
MTY DRG.LOCAL \$13.146 - 3 UNITS EDPR 1600
SOUTH PAB04.CC806 - 8 UNITS - 3200 TONS EDPR 1500
PB806 - 6 UNITS EDPR 1430
LDS SOUTH - 8 UNITS - 3200 TONS EDPR 1800

DATA REQ OUTSTANDING
WEIGH - 286 -OVER 24 HRS- 1485.6G5.1FP
CREW ON DTY - 3
CREW OFF DTY - 2
ARRIVAL TIME - 1
DEPARTURE TIME - 1
CONSIST - 2
WORK PERE - 6 - OVER 16 HRS - X2543
CORRN TO CONSIST - X4039-08HRS-2 CARS NOT REPORTED
X4685 - 32 HRS - PU OF CAR NOT REPTD
DIVERSIONS - 1

SP 136542 - AR X4692 - CHECK SEALS, HI VALUE
SP 206542 - IN YD - WIDE LOAD

EXPLANATION OF ABBREVIATIONS
Yard, Time, Date
Loads/Empties/Tons-Trains
Zone, Loads/Empties, Car Orders Filled, Open
Cleaning Track, Number and Type
Loads/Empties
DBR (Car Distributor), Number and Type
Released But Still On Spot
Cars to be Weighed
Standard Period
Initial Card Number Of Delayed Loaded Cars
Delayed Empty Car
Train Description, Estimated Arrival Time
Estimated Arrival Time Revised
Estimated Departure Time
Data Requests Cards Outstanding
Correctious to Consist-Train-Delay
Messages

NOTE: This illustration is a 45% reduction of the actual report size.

FIGURE 2-9 SITUATION AND TURNOVER REPORT

identification, etc. Upon receipt of the inquiry, the central processor will compile the requested information and send it to the clerk.

Correction Procedures

Errors that could occur during the course of a car movement cycle can be classified into three general types:

1. Logical Errors - These are errors which the central processor can detect because the data received was logically inconsistent. For example, a certain car was reported to have been pulled from a spot before it was sent to that spot. In cases like this, the central processor will issue an "Error Message" to the reporting yard. In the above example, the central processor will issue a message giving the car initial and number, last recorded data, and error condition (i. e. , no spot data). The local clerk will be responsible for correcting the data.
2. Lost Card - If the local clerk realizes he has lost a card, he may report this fact to the central processor which will re-issue the card to him. In the case of Data Request Cards, the central processor will wait a certain amount of time for the request card to be entered. If it is not entered, the central processor will send a message to the yard stating that the data has not been reported. If the clerk reports that the Data Request Card was lost, the central processor will issue a new one. Thus, the central processor continuously monitors certain types of data to ensure that the data is reported.

The exception to this procedure occurs when the lost card contains completely new data not yet reported to the central processor. This can happen in the case of Pickup/Setout cards. When a conductor picks up a car along the line but cannot locate its pickup card, he will make out a new Pickup/Setout card set, indicating on it that the pickup card has been lost. When the car is set out short of an I/O unit, the conductor will follow the procedures prescribed previously, except that the new pickup card will replace the lost one. The conductor will turn in the new setout card without a pickup card at his terminating point. There, the clerk will punch the car initial and number, location and status and transmit this data to the central processor. The central processor will re-establish the movement record for the car, and check the data entered on the new setout card against the data it already has in its records. If the data is not consistent, the central processor will output an error message to the dispatcher who will be responsible for tracing the car's movement and correcting the central processor's record.

The clerk will check the documents turned in by the conductor to determine that there are no missing data or lost cards. If there are, the clerk will be responsible for locating the missing data or cards and entering this information into the TOPS System.

3. Bad Data - There may be errors in punching or in interpretations of the data even though the entry itself is logically correct. These are errors such as wrong weight, destination, etc. There are many ways in which erroneous data may be detected, but this type of data will normally be spotted by clerks who handle the consist cards and waybills. When an error is detected, the clerk will try to determine the correct data and transmit it to the central processor. The central processor will retain both pieces of information in its files and issue to the dispatcher, once every eight hours, a listing of all errors corrected with the correct and erroneous data shown. If the local clerk cannot correct the data, he will transmit a message to the central processor to indicate that a certain piece of data in the central processor is in error. The central processor will note this condition on its records, and will also issue a message to the dispatcher describing the car and the data suspected to be in error. The dispatcher will be responsible for subsequent correction.

INDUSTRIAL ZONES DIRECTLY ASSOCIATED WITH A MAJOR YARD OFFICE

Whenever a group of stations or spurs is regularly switched entirely by a specific set of engine assignments operating out of a yard office location, these stations and spurs will be grouped into a zone and numbered accordingly. The yard office concerned will be designated as Industry Service Center (ISC) for the zone and will co-ordinate all operations and data gathering from the zone. Almost all industrial areas associated with major operating points fit into this category, as well as certain branch lines or sections of mainline that are regularly serviced by turn-around locals. For a description of procedures in the Industry Service Center, refer to that section in the Major Yard Office procedures.

Agents in Zone Areas

The local agent will normally relay any releases and car orders directly to the Industry Service Center for his area. In addition, the agents will function as "support clerks" to the ISC for any ground checking required by the ISC in his area.

Interchange in Zones

When cars are received at an interchange in an industrial zone, which includes a branch line or section of mainline spurs, a switch list of the cars will be manually prepared; this list will indicate the disposition of each car. One copy will be used by the conductor and the other will be transported to the ISC with the waybills.

Conductor or Engine Foreman Operating in Zone Areas

When leaving his home yard, an engine foreman or conductor will be provided with listings showing the following:

1. A spot list, which lists every car in his outbound cut or train from the local yard, and indicates the car initial and number, spot location and any special instructions pertaining to the car.
2. A zone check, which lists every spur in his work area on which cars are currently spotted or placed and indicates after each, the car initial and number, proper spot and any special instructions for the cars on the spur. On certain specific spurs these cars will be listed in track order; however, in general, the listing will simply indicate the car is somewhere on the spur.
3. A pull list, which lists cars in the zone area to be pulled, and indicates car initial and number, any special instructions, and the destination for the car if this is other than the home yard.
4. Any car orders he is to fill with cars available to him indicated on his lists.

As switching is performed and cars are placed on spot or pulled, the time of these movements will be noted by the engine foreman on his lists opposite the appropriate car initial and number. For cars set out, the actual location at which the car was left will also be shown. Cars constructively placed will be so indicated. If the engine foreman picks up or re-spots a car not included on his pull list, he will note, opposite the car initial and number on the zone list, the time of the pickup and setout, new location of the car, and reason for movement. As a conductor spots cars to fill a car order on his list, he will note the car's initial and number after the car order.

If a conductor picks up cars not included on his lists, he will either add the car initial and number on the back of his own list, or pick up a switch list that has already been made. On these manually prepared lists, he will note his re-spot moves exactly as any other re-spot and indicate time picked up and set out and new location of the car.

Upon return to the yard area, the conductor or engine foreman will turn in all lists to the ISC as his record of the work performed.

Pickups and Setouts by Mainline Crews for Zone Spurs

When a train from outside the zone sets out cars at a local siding to be picked up by the regular zone crew for spotting, the train crew conductor will leave behind a pickup card for each car and a switch list. These will be picked up by the zone crew conductor. The zone crew conductor will indicate the spot information on the switch list in the same manner as spots are noted on his other lists. The pickup cards, way-bills, and all lists will be taken to the ISC at the end of the zone crew conductor's tour of duty.

When cars are set out by the regular zone crew on a local siding to be picked up by a mainline train, the zone crew conductor will prepare a Pickup/Setout card set for each car, indicate the setout, and leave the pickup cards with the movement documents for the cars in a convenient bill box, so that train conductor can pick them up along with the cars. The setout cards will be turned into the ISC with the lists and movement documents.

Southern Pacific Company

LOCAL AREAS NOT ASSOCIATED WITH A SPECIFIC MAJOR YARD OFFICE

For all areas not directly associated with a particular major yard office such as a zone, the following procedures will apply. In general, most communications and procedures will be conducted as at present, and will be modified only to integrate them with the new procedures at the major yard office. The one notable exception involves the area of reporting the conductor's wheel movements. It is proposed to eliminate all documents currently prepared by a conductor to indicate car movement, location or status (i. e. , wheel reports, blind siding reports, conductor's pickup and setout reports, etc.). These would be replaced with a reporting technique which records, on a punched card form, car movements and changes of status as they occur. As with previous reports, these are made out only by the personnel directly involved.

Whenever a car is set out in a remote area, there will be a punched card left with the car on which data will be recorded and subsequently reported into the TOPS System. When a conductor picks up a car, he will pick up the card left with the car, together with any movement documents, in the same manner waybills are picked up at present. All such cards will be taken by the conductor to the nearest major yard office or crew off-duty point, and will be used to enter the data on the cards directly into the TOPS System. The conductor will leave a new card with a car every time that car is set out.

Conductors Performing Work in Local Areas

When leaving his initial terminal, the conductor will have the following documents:

1. Conductor's Train List, showing, in train order, the cars in his train and any special instructions.
2. Work Orders or other messages directed to him by car distributors, dispatchers, etc.
3. Waybills, Bills of Lading, or other movement documents for cars in his train.
4. Included in the fold of certain movement documents he has received will be Pickup/Setout card sets already prepared for his use whenever a car is to be set out at a point other than a major yard office location.
5. Blank Pickup/Setout card sets with carbon, to be used for indicating unpredicted setouts.
6. Train Orders, clearances, etc.

Whenever a setout occurs, the conductor will complete a Pickup/Setout card set for the cars concerned, and include on this set the time and exact place of the setout. Such a setout card set will have to be completed by the conductor for all setouts occurring at other than major yard office locations. In most cases, the form will have been prepared previously by the I/O unit at the originating station or by agents enroute; these will have been included in the fold of the movement documents

Southern Pacific Company

covering the car concerned. If no such pre-punched Pickup/Setout card set is available in a movement document, the conductor will prepare one himself, using one of the blank Pickup/Setout card sets with which he has been supplied. The format of the cards has been previously illustrated in Figure 2-2. When a setout occurs the conductor will leave the pickup portion of the card set locally with the car in a place designated by operating rules. These rules may specify such places as: an agent's bill box, a shipper's loading dock, a box in the caboose, a telephone booth, or a document container along the right-of-way. (The cards will not be attached to the car.) Meanwhile, the setout portion of the card set will be carried by the conductor to his terminating point and submitted in lieu of a wheel report.

Whenever the conductor picks up a car enroute, he will also obtain the pickup card that remained with the car locally. If no car is found locally, as indicated by local operating rules, the conductor will use one of his own blank Pickup/Setout card sets to prepare one. The conductor will take all such cards to his off-duty point and turn them in (with any setout cards mentioned above). If the car is pulled from an industrial spur or "hold" status, the conductor will ascertain that any release information had been entered on the card form in the appropriate manner.

If a car previously picked up along the line is subsequently set out at another location along the line, the above setout procedure must be followed; i. e. , a new Pickup/Setout card set is filled out manually, the pickup portion is left with the car and the setout portion is turned in at the conductor's terminating point. For such a car, the conductor would then have two cards to be turned in at his terminating point, one indicating pickup information and the other setout information.

In many situations, the car distributor will make available to the local conductor, either along the line or by including them in his outbound consist from the originating terminal, a pool of cars from which the conductor may fill car orders placed by specific local patrons. A list of such cars will be included in the work messages given to the conductor with his outbound conductor's train list. When a patron orders a car for loading and the conductor spots it from his pool, he will use the regular pickup-setout procedure as outlined above. The Pickup/Setout cards turned in at his terminating point will indicate the placement of the car for loading. When no car is available, however, he will prepare a special car order form which will be left with a specific local agent or taken to his terminating point, as specified by local instructions.

When bad orders occur enroute, a conductor will follow all current operating instructions regarding the inspection and further movement of the car. He will also contact the dispatcher, as at present. When the car is finally left at some remote location, the conductor will prepare the two-card Pickup/Setout card set as described above, take the setout card to his terminating point as part of the wheel moves, and leave the pickup card locally as prescribed by rule.

When some type of service is performed on a car and a record must be forwarded to the central processor (weighing, changing vents, etc.), the conductor will make a note of the service performed on his train list and turn it in at his terminating point with his Pickup/Setout cards. This information will be punched in cards and entered into the central processor together with the car movement records.

Upon arriving at his terminating point (if this point is not a major yard location) the conductor will complete a Pickup/Setout card set for each car he brings into the local yard. The pickup card from each set will be used in the yard office in a local PICL file; the setout card will be added to the Pickup/Setout cards the conductor turns in for subsequent entry into the central processor with the conductor's wheel moves. If a conductor terminates at a major yard location, the conductor will not prepare the two-card sets for the cars brought into the yard; instead, these will be indicated on a train list and the clerk at the I/O console will be responsible for closing out the wheel record. At his terminating point, the conductor will thus turn in the following:

1. Waybills, bills of lading, or other movement documents for cars brought into the yard by his train.
2. A pickup card for every car he has picked up locally, indicating the time of pickup.
3. A setout card he has completed for every car he has set out, indicating the time of setout, exact location of the car and reason for setout.
4. The setout portion of the Pickup/Setout card set he was required to prepare if a pickup card for a car he has picked up locally could not be found or had not been made.
5. Setout cards or train list for the cars brought into the final terminal, in train order.

Agents in Local Areas

Normally, local agents will not be equipped with an I/O unit; most of the data they generate will be sent to the nearest major yard office, either by telephone, on the face of the pickup card left with cars spotted in their area, or by the same reports they currently prepare. When it is found desirable, however, to rapidly collect data generated at some specific local station in order to avoid untimely delay or loss of accuracy, the local agent will be equipped with an IBM 10 Card Punch and an IBM 1001 Card Reader and Transmission Set. The latter unit, instead of being connected directly into the central processor through special communications circuits, is attached to the agent's telephone. When the local agent has cards to read into the TOPS System, he can dial a special extension number indicated to him and then use the card reader and transmission set, to send the information to the central processor.

Releases

When a local patron indicates the release of a car, it will be noted by the agent directly on the face of the pickup card that was left with him when the car was spotted. This card will be picked up by the conductor pulling the car and will be carried by him to his off-duty location where it will be read into the central processor.

If the local agent is equipped with an IBM 1001 Card Reader and Transmission Set, he will punch the release information into the pickup card and forward it to the central processor.

Interchange Delivered

When cars are delivered on interchange at remote locations, the conductor or local agent will complete the pickup cards for the cars, noting the interchange point, connecting carrier and time of interchange. He will also make two copies of a transfer list, one for delivery to the connecting carrier and one as a local reference.

The data noted on the face of the pickup card will be punched into the card which will then be placed behind an interchange header card and the data will be transmitted. If the interchange point is not equipped with an IBM 1001 Card Reader, the pickup cards will be sent to the nearest yard with an I/O unit where the data will be punched and transmitted.

Interchange Report

Whenever local interchange procedures will permit, all interchange reports will be prepared centrally and mailed to the connecting carrier. When an interchange report must be prepared locally, this report may be prepared manually as is now done, or may be prepared at the nearest major yard office as described in the Major Yard Office Operations.

Interchange Received

When cars are received on interchange at remote locations, a Pickup/Setout card set will be prepared by the conductor or local agent. The Pickup/Setout card set will show interchange point, car initial and number, load or empty and all the data required for an interchange entry. The setout portion will be included in the folds of the waybill and the pickup card will be handled according to standard procedures. When the car arrives at a major yard office, the setout card will be used by the clerk to make the interchange entry for the car.

All interchange points within a division at other than major yard office locations will send one copy of the Interchange Report to a selected location on that division. The central processor will issue daily listings of all cars interchanged at remote interchanges within that division. A clerk at that location will be responsible for checking these lists to discover any errors or missing data.

Car Orders Placed at Local Points with a Card Reader and Transmission Set

At these local points, only repetitive car orders will be entered into the TOPS System through the IBM 1001 Card Reader and Transmission Set. All other orders will be phoned to the ISC clerk in the nearest major yard office. This procedure will be followed for specific car orders and agent's "blanket orders". The repetitive car order procedure will be very similar to that described for the major yard office.

The clerk at the local point will record the order on a car order card. If this is a non-repetitive order, he will phone the information, including car order numbers, to the major yard office for input; normally, he will save his orders and phone

Southern Pacific Company

them in batches two or three times each day. The clerk at the major yard office will write the order on a "local-order form" that is similar to his regular order form with the exception that there is no pre-punched number in the card.

If the incoming order is repetitive, the local clerk will write on the car order form the variable information, repetitive code, and whatever repetitive information he desires. Then he will punch into the card the number of cars wanted, the time and date wanted, the destination and the repetitive car order number. He will punch the route, if one has been specified, in a blank card. Since the IBM 10 Card Punch located at the local point cannot punch alphabetic data, the destination and route must be coded. The clerk will enter both cards into his card reader and transmission set, inserting the car order first. Then he will write the order number on the following card for identification, and file the order card in order number sequence. The follower cards will be stored in a separate file for reference.

Cancelling and Changing Orders

Should a patron cancel or change a repetitive car order, the clerk at the local point will re-enter the order card behind a "cancel order" or "change order" header card, respectively. In the second case he will also enter a third card which will contain the corrected information. The central processor will then correct the car order in its record without changing the order number. If a patron cancels or changes a non-repetitive car order, the clerk will phone the ISC clerk at the appropriate major yard office.

Confirming Orders

When a conductor has taken a pool of cars to fill local orders, the local ISC clerk will re-enter the order card into the TOPS System to indicate that sufficient cars are prescribed to fill the orders. If the clerk determines, through contact with the patron, that the orders were not filled properly he will follow the procedure described in the next section. When local conditions permit, the pickup cards for the cars prescribed for particular orders will be entered into the central processor with the order cards. Then, when cars have been spotted, the order cards and the setout cards will be transmitted behind a "confirm order" header card. If these assignments do not agree with the cars prescribed or the cars wanted (as indicated in the original car order), the central processor will transmit a message to the distributor. If local operating conditions do not permit confirmation, the initial entry of pick up and car order cards will be allowed to stand unless the patron advises the clerk that he will not accept the cars prescribed. In that case, the local clerk will carry out the "Order Not Filled" procedure.

Orders Not Filled

When the local clerk learns that an order is not properly filled, he will enter the car order card in the reader behind an "Unfilled Order" header card. This indicates that the order is still outstanding. At points where orders are not confirmed, the distributor will not be advised of the cars actually used until input of the setout cards describing the car movements is performed.

Southern Pacific Company

Local Points Without a Card Reader and Transmission Set

Each local agent at local points will be responsible for phoning his car orders to a specified ISC clerk at a yard equipped with an IBM 1001 Card Reader and Transmission Set or an I/O unit; or, the local agent may contact the car distributor directly. These points will enter the order as described in their respective procedures and assign a car order number to each order which is phoned in. When the local agent has received cars to be spotted for his orders, he will again phone the same point and indicate this condition. Likewise, should he learn that for some reason one of his orders was improperly filled, or that a patron cancelled or changed a car order, the local agent will phone this information in. In both cases, the information will be entered according to the procedures for the various points.

Train Originating at Local Points

Almost every local point at which local crews go on and off duty is equipped with an IBM 1001 Card Reader and Transmission Set through which information about the train can be transmitted to the central processor for incorporation into the train record. If any point is not so equipped, the data will be communicated to the location of the nearest I/O unit or to the dispatcher, for input.

If a local point is equipped with a card reader and transmission set, the following procedure will apply. The clerk will have been supplied with a stock of "Train Origination" card packs. These consist of three or four cards, depending upon the location and type of train originating; each card identifies a different type of data required about the train, its locomotives, departure time or crew. The cards will also contain several columns of pre-punched identification and marked areas into which the agent or operator will punch the designated data. These cards may or may not be entered together, as convenient. After input, however, they will be associated and filed as the local record describing the train origination.

The clerk will then assemble or prepare Pickup/Setout cards for the cars the train will take from the local yard, if he has not already done so, and place these in the folds of the waybills for the conductor's use. If the train will pass through or terminate at a major yard, the clerk will place the pickup cards that represent the cars in the departing train behind the card in a "Train Origination" pack that is to identify a consist; he will then transmit these cards to the central processor in train sequence. If the train will not pass to or through such a yard, a consist entry will not be made. Likewise, if the agent is not on duty when the train originates, the pickup cards will not be available for this entry and the entry will not be made.

Train Terminating at Local Points

If the local point is not equipped with a card reader and transmission set, the documents and designated data about the terminating train will be sent to the most convenient location for entry. Also, certain vital information will be communicated to the dispatcher, who will enter the data through his own I/O unit. If the local point has a card reader and transmission set, the following procedure will apply.

Southern Pacific Company

The clerk will have been supplied with a stock of "Train Termination" card packs. The various cards in a typical pack describe the data required and provide room for the data to be punched. These cards need not be entered together; however, after all have been entered, they will be re-associated and filed for reference.

Upon arrival at the terminating point, the conductor will turn in the following:

1. Pickup card for every car picked up or re-spotted.
2. Setout card for every car spotted or re-spotted.
3. Movement documents.
4. Note of services performed (weights, change vents, etc.).
5. Unfilled car orders he has received from patrons and/or notes regarding his own car supply.
6. Other documents he would regularly turn in at his terminating point.

The agent or operator who prepares the data entry will first punch into the Pickup/Setout cards the data contained on them; then he will take the "Train Termination" pack and, from the documents turned in by the conductor, punch the designated items regarding arrival time, off-duty time, a code for claims, locomotive usage, etc. Every setout card will be placed behind a pickup card for the corresponding car. Weights and other servicing data will be punched into pre-punched "Service Cards" and placed behind the pickup/setout cards for the car concerned. These cards will then be placed behind the header card provided in the "Train Terminate" pack. All cards will then be transmitted to the central processor.

If the conductor has turned in any car orders, either for patrons that have communicated with him or for his own use, these will be handled by the local agent as one of his own car orders. Moreover, cars picked up at an interchange track will be handled as if they were interchanged locally.

The agent, operator, or conductor will assemble or prepare Pickup/Setout cards for cars left by the conductor and place these in the folds of the waybills for the next conductor's use.

Crew Change at Local Points

Whenever an intermediate yard is equipped with a card reader and transmission set in place of a full major yard office I/O unit, the local operator will treat a crew change as a "Train Termination" and a "Train Origination" packs will provide space for codes that indicate the fact that this is a crew change entry; also, certain other cards in the pack will not be used as indicated on the face of the cards.

Track Checks from Selected Local Points

From time to time the clerk at such a location will transmit, upon request, a track check of his responsibility area to the central processor. He will do this by pulling from his PICL file the pickup cards for all the cars and transmitting them into the TOPS System.

Southern Pacific Company

DISPATCHER PROCEDURES

Equipment

In each dispatcher's office there will be an I/O unit consisting of a keyboard and printer, a paper tape punch and a reader. This I/O unit will transmit information to the central processor and receive messages from it. The dispatcher's typed input will be held temporarily at the I/O unit and transmission will not commence until the clerk has completed the message. This arrangement allows more efficient use of the transmission lines, while involving only a brief interval between typing and transmission. The typewritten copy of the dispatcher's transmission may be checked for errors and retained for reference.

The I/O unit will be able to receive transmission from the central processor except, of course, while it is sending. If the central processor has a transmission for a unit that is being used, an indicator light will flash on the printer of the I/O unit. When ready to receive the message, the dispatcher (or clerk) sets a send-receive switch which connects the I/O unit to the line to receive the message. When a dispatcher is not using his I/O unit he will leave the switch set to receive.

The I/O unit may also be used as a regular electric typewriter for any ordinary tasks that do not involve transmission into the TOPS System. When used in this way, the indicator light will still turn on if the central processor has a message for the dispatcher.

Report and 24-Hour Line-up

The chief dispatcher will submit, once during each shift, a 24-hour line-up with estimated schedules for all through and regularly scheduled trains. Several sources of information will be available to aid him in preparing this line-up. These include:

1. A report which will abstract for him the number of cars in each yard, industrial zone and along the line, and give the total number of cars for the tag destinations indicated in the car's operating records. The number of cars will be classified as to empties and loads and, also, by tonnage totals for these destinations.
2. A report showing the location and utilization of each locomotive unit and the direction and destination of those that are moving. A separate yard engine report will be transmitted to the dispatcher's I/O unit soon after the beginning of each shift. This report will indicate the switchers currently on duty at each locality and the off-duty information about the switchers on duty during the previous trick.
3. The chief dispatcher will be in close contact with the car distributor who may be modifying his plans for the movement of empties.

After the beginning of the day shift, the chief dispatcher will prepare the line-up and estimated schedule on a form, and indicate the origin point, train designation or symbol, estimated call and departure time, and the estimated arrival and departure times at crew change points, major yards and terminating points. A clerk will enter the information into his I/O unit.

Southern Pacific Company

The 24-hour line-up and estimated schedule will be distributed by the central processor to the Superintendent of Transportation, the Mechanical Department, the car distributor and the yardmaster in each chief dispatcher's territory. Also, subsequent dispatchers will receive through train schedules.

Placing a Call

As aids in deciding when to call a train, the dispatcher has reports on locomotives, a report on cars with movement instructions for each yard and area in his territory, and the chief dispatcher's estimated line-up and schedule for the next 12 and 24-hour period. The dispatcher is in close contact with the yardmasters in his territory. When he has determined to call a train, he will implement the following procedures.

The dispatcher officially calls a train by filling out a small "Call Form" with the following information: train designation or symbols, numerical designation and date, origin station, locomotive units to be used, call time, estimated departure time (if different than his call time), and intermediate and terminating yards with estimated arrival and departure times through his territory and through major terminals in subsequent dispatcher's territories enroute to the train's termination point. He will also give a brief consist description and tonnage, if this is not obvious by the train designation. He will give this form to a clerk who will enter a code number into his I/O unit indicating a call and include the above information with each item on a separate line in the prescribed order.

This input will set up the train record in the central processor, start data collection at the initial yard office (see Yard Office Procedures), and send a message to subsequent dispatchers to indicate the calling of the train.

Intermediate Yard

When the train is approaching an intermediate yard, the dispatcher repeats the initial call procedure by placing a call at the intermediate yard. He will repeat the above procedure, except that "Origin Station" will become "Intermediate Station", and the arrival and departure times input will represent a schedule revision.

Calls at Local Points

When a train is being called at a station other than a major yard office location, the dispatcher will carry out the same procedure as for a major yard office. This includes the present procedure of phoning the local operator to confirm the call directly, and to give any train orders and messages to the crew.

Departure Reports and Schedule Revision

As the train departs and the departure time is entered into the central processor, a departure report containing the departure data, crew data, locomotive data and a

Southern Pacific Company

summary consist is prepared by the central processor and transmitted to the dispatcher in message form for his information. If there is incorrect information in the departure report, he will correct it by making out a new departure report. The clerk will enter this into his I/O unit with the proper code to indicate that it is a correction to the departure report. If a late departure radically changes the train's expected arrival time at subsequent terminals, the dispatcher may also enter a revised schedule at the same time. If the schedule revision is the result of an unexpected occurrence on line, it may be entered as part of a call to an intermediate yard. This will indicate train designation, revised estimated times of arrival and departure at intermediate and terminating yards along the line, and location and times of delays. If no corrections or revisions are necessary, the dispatcher will transmit an approval code. The dispatcher's clerk will enter this information through the I/O unit in the same manner as the original call, using the proper code. This revision will be transmitted by the TOPS System to the I/O units concerned.

Train Terminates

Normally, when a train reaches its terminating yard, the local yard office will input the arrival and off-duty data. In cases in which a crew goes off duty without an I/O unit available, the off-duty and arrival time will be phoned to the dispatcher's office. The dispatcher's clerk will enter the information into the central processor through his I/O unit. When a train has terminated at a local point, the dispatcher may notice work not performed or data not satisfactorily submitted from the field. He would then collect this data.

Train Performance Report

When the train has terminated, the central processor will make a final check for missing or inconsistent data, and go through certain procedures to correct such data. If the data cannot be satisfactorily corrected in a certain period of time, the correction responsibility will be shifted to a central authority and the central processor will compile an interim train report; otherwise, a regular train report will be compiled. A train performance report then will be compiled and issued in message form to the dispatcher and the Superintendent of Transportation, and other supervisory personnel. Where required, the dispatcher will check the data verify claims, etc. and add explanatory notes about the items or delays encountered.

Undesignated Car Moves

Departure

Upon receipt of an outbound consist from a yard office, the central processor will check the disposition of each car to make sure this move does not conflict with the current destination or assignment of the car as indicated in the central processor's car movement record. When such a conflict is discovered, a message describing the improper move would be sent to the appropriate I/O unit.

The message distribution will include:

1. Dispatcher - for all such cars.
2. Car Distributor - empties, special equipment, assigned service cars, and certain types of cars in short supply which he has specified.
3. Responsibility/Location Area for Whom Car is Held - for cars in hold status.
4. Responsibility/Location Area which Requested Service Requirement - for cars moved without servicing indicated.
5. Local Yard Office - for all such cars.

The dispatcher will take all necessary action to assure that these conflicts are corrected by the yardmaster before the train departs, if conditions permit. He may also communicate with the distributor or other personnel concerned as indicated.

Arrival

Upon arrival of a train at an intermediate or terminating point, the arrival data, work performed enroute, and the local interchange and release are entered into the TOPS System. The central processor will again check the disposition of each car to make sure the move does not conflict with the current destination or assignment of the car as indicated in the car movement record. In this case, the same people would get messages and the situations would be handled as described above.

Inconsistent or Missing Data

The central processor will make certain checks of the train record for inconsistent or missing data. When such a condition is discovered, "correction request" messages and/or cards will be sent to the proper I/O unit for correction. In some cases, other I/O units will aid in the procedure by monitoring the correction. In other cases, a separate message will be transmitted to a central correction authority, who will manually transmit correction request messages giving the original data entry and indicating the bad or missing data. This central authority will be responsible for correcting the records in the central processor.

Whenever an I/O unit receives a data correction request, it will be responsible for re-entering the correct data in its normal form.

Inquiries

The dispatcher will be able to request information, such as the location of a car or the status of a train, by keying into the I/O unit a code number followed by car initial and number or a train designation.

Bad Orders Set Out on Line

In the event of a bad order on line, the train crew, in addition to preparing a Pickup/Setout card set, will immediately contact the dispatcher and give him the car initial and number, its location and reason for bad order. The dispatcher will contact the Mechanical Department as he does presently, then key into the I/O unit a code indicating that a bad order has been set out, and transmit all data pertinent to the bad order. The central processor, in turn, will transmit messages to the appropriate I/O units as follows:

1. Mechanical Department (to the I/O unit, designated by the Dispatcher) - all bad orders (to confirm the dispatcher's telephone call).
2. Traffic Department - all loaded cars.
3. Car Distributor - empty cars, special equipment, assigned service cars, and cars under his control.
4. Nearest Yard Office - designated by the Dispatcher.

If the bad order causes a delay, the dispatcher will indicate this condition in his next schedule revision. If a setout card is entered to report a bad order setout before the dispatcher makes his entry, a message will be sent to the dispatcher.

CAR DISTRIBUTION PROCEDURES

Introduction

The car distribution procedures are designed to relieve the car distributor of the clerical burdens of collecting and organizing data, tracing cars, etc. The TOPS System will also aid the car distributor by relaying his instructions to local operating personnel and by automatically monitoring the car movements to insure that his instructions are followed. Features of the car distribution procedures are:

1. All required information will be gathered and made available by the operating and car order procedures.
2. The central processor will automatically organize the data and prepare reports in the desired formats. This will include reports that are automatically prepared on a periodic basis, as well as others that are prepared only upon request.
3. The distributor can adjust the amount of detail in the reports concerning location or type of car to suit his needs.
4. In regulating the car supply, the car distributors instructions will be recorded in the car records in the central processor. Distributors will be automatically advised if their instructions are not properly carried out.

Equipment

The basic equipment for a car distribution office will be one or more input-output (I/O) unit each consisting of a keyboard and printer, and paper tape punch and reader. Regional high speed printers located at San Francisco, Portland, Los Angeles and Houston will be used for report preparation.

The I/O unit will transmit and receive messages from the central processor. The message typed by the distributor will be held temporarily at the unit and transmission will not commence until the message has been completed.

The I/O unit will be able to receive transmission from the central processor except, of course, while it is sending. If the central processor has a transmission to make to a unit that is being used, an indicator light will flash on the printer. When ready to receive the message, the distributor (or clerk) will set a send/receive switch which permits the I/O unit to receive the message. When a distributor is not using the I/O unit, he will leave the switch set to receive.

The I/O unit may also be used as a regular electric typewriter without transmission to the TOPS System. When used in this way, the indicator light will still flash if the central processor has a message to send to the I/O unit.

Organization

The TOPS System includes the creation of four regional car distribution offices. From a procedures standpoint, the advantages of centralization of car distribution are greater central control and savings in input-output equipment. The limit of centralization is determined by the communications cost. The four regional offices will assume responsibility for car distribution over the appropriate areas now handled by the indicated division distributors:

| | |
|---------------|--|
| Portland | Portland, Shasta, Salt Lake Divisions |
| Los Angeles | Los Angeles, Tucson and Rio Grande Divisions |
| Houston | Texas and Louisiana Lines |
| San Francisco | Coast, Western, Sacramento and San Joaquin Divisions |

These offices will be co-ordinated from the System Car Distributor's office located in the General Office.

System and Regional Car Distributors

In the following procedures, anyone performing a distribution function in a regional or the system car distribution office will be referred to as the "regional car distributor" or the "system car distributor". The procedures for both regional and system offices are very similar. For this reason, the procedures for each function will be described together and the differences will be explained.

The TOPS System looks at each division of the railroad as divided into many local operating areas which are referred to as Responsibility/Location areas

(R/L areas). The records and reports of car location, car orders, etc., will be grouped according to these Responsibility/Location areas which will be of three general types:

1. Yards (including cleaning and rip tracks).
2. Industrial Zones.
3. Other Local Areas (not serviced by major yard offices).

Car Distributors' Reports

The car distributors' procedures are based upon three basic reports:

1. The "master report".
2. Detail lists.
3. The "Situation and Turnover Reports".

Also available to the car distributors are consists and consist summaries, train performance reports, line-ups and schedule information, etc., as presently used.

The reason for providing the distributor with a summary master report and making supplementary detail reports available upon inquiry, is to avoid flooding the distributor with unnecessary detail, and still furnish the ability to obtain all the detail he requires, upon request.

The car distributor will receive the master report three times a day (for example, at 7:00 A. M., Noon, and about 4:30 P. M.) which will summarize for him the data he normally uses. He will examine this report, determine the areas and situations needing closer attention, and request supplementary detail reports for these. Using these reports, and keeping in close touch with dispatchers, other distributors and other management personnel as presently done, he will plan his action and issue movement instructions.

Master Reports

The Master Report presents a summary, within each location and for each kind of car, of orders on hand, cars available (classified and unclassified), and certain monitoring information. An example of the proposed Master Report is found in Figure 2-10. It is similar for both the system and regional car distributors except that the Master Report prepared for the system distributor will have regional summaries and may include all regional reports and summaries.

The Master Report can be organized in a variety of ways; in its most simple form it would present, for each location, information for every kind of freight car. A more likely arrangement for most distribution offices includes separate sections of the report for various kinds of cars. Thus, one section could represent the information on certain types of special equipment for each location; another section could

the information for all closed cars, and another for assigned service cars, etc. These sections will be separated and will allow use of the different sections of the report to those persons who are concerned with the distribution of various kinds of cars. The system and regional distributors may, therefore, choose the report arrangement that suits their requirements. Figure 2-10 illustrates one possible organization for the report.

Detail Reports

On the Master Report, each line has a reference number and each column is lettered; also, the central processor will have assigned a reference number to the report itself. When the distributor examines the report and decides the information on the Master Report is not sufficient, he will request specific detail in those locations of interest to him. He does this by keying into his I/O unit the report reference number, a line reference number, and the column letters of the specific items he desires to have expanded. For example, he may ask for a list of only the double door box cars (B4's and B5's) in certain locations, or for only the bulkhead flat cars of a particular classification, etc. In some cases, he may want all the detail for a particular location or for a certain type of car within his responsibility area. In this case, he would simply key in the line reference number and the column references that indicate the name of the location and the kind of car within that area, and he will receive in detail all the pertinent information. In either case, the central processor will transmit the detailed listings to him via the high speed printer.

For example, if the car distributor entered into his I/O unit the Master Report Number (ML), the line reference number (102) and the column letters (E, F, G, H), (taken from Figure 2-10) the Empty Car Location Detail List shown in Figure 2-11 would be produced. Or, if he entered the appropriate line reference numbers and the column letter C, from the master report, he would receive a Car Order List such as the one shown in Figure 2-12.

Note that the detail lists present all the data about the cars and car orders needed to match individual cars and car orders. Within each location the cars of each type are grouped together showing siding or spur number (or yard) to facilitate distribution of different types of cars separately.

Partial Lists

Also, the distributor may ask for certain partial transmission of detailed lists. For example, instead of asking for all the classification box cards in a particular location, he may specify only those cars with certain classifications. The central processor would then transmit information on only those cars which apply. Generally, after reading his Master Report, the distributor will request all the detailed reports he wants in one batch. He may, of course, also request further reports if necessary.

| LOCATION | STA. NO. | SPUR AND SPOT NO. OR TRACK NO. | OR | INITIAL AND NUMBER | LENGTH | DOOR WIDTH | CAPACITY | | EQUIP REG. FOOT-NOTE | REMARKS | CLEANED | | NOT CLEANED LAST COMMOD | TAG NO. OR STATUS | DAYS IN STATUS | |
|----------|----------|--------------------------------|----|------------------------|--------|------------|----------------|-------|----------------------|---------|---------|------|-------------------------|-------------------|----------------------|-------|
| | | | | | | | CUBIC 1000 LB. | 100'S | | | GRADE | DATE | | | | PLACE |
| BROOKLYN | 1579 | 1909-017 | OR | B4 SP 63792 | 41-9 | 14 | 35.27 | 100 | JJ | | GRADE | 1-23 | FRSNO | HLDYM | 2 | |
| | | | | BL SP 110190 | 51-9 | 8 | 49.09 | 100 | V | | GRADE | 1-25 | LA | | 0 | |
| | | | | 1903-021 F4 GN 117892 | 43 | | | 80 | | | | | | | | 3 |
| | | | | 1910-007 G UP 229500 | 54 | | | 22.44 | 140 | W | | | | | LOGS SCRAP OIL | |
| SEARLES | 3049 | 1707-011 | OR | T MP 6136 | 31-5 | | 105.90 | 100 | | AUTO | GRADE | 1-24 | LA | | 5 | |
| | | | | 1703-001 DF ATSF 11220 | 52 | 8 | 48.70 | 100 | | | | | | | HLDDBR | 1 |

FIGURE 2-11 EMPTY CAR LOCATION DETAIL LIST

| SP ORDER NO. | LOCATION | STA. NO. | CARS WANTED | | | CAPACITY | | COMMOD. | REMARKS | SHIPPER | SPUR. NO. | ON LOADS | DESTINATION AREA CODE | ROUTE |
|--------------|-------------|----------|-------------|------|-------|----------|-------|-----------|-------------|-------------------|-----------|----------|-----------------------|---------|
| | | | KIND | NMBR | MONTH | DAY | CUBIC | | | | | | | |
| 17376 | ASHLAND | 14785 | B5 | 3 | 1 | 26 | | PLYWOOD | | ACME LUMBER | 0317 | 21 | SOU | |
| 17125 | | | B5 | 1 | 1 | 26 | | VENEER | B4 OK | KEFALTER MILLS | 0329 | 06 | CRIP LN | |
| 16873 | | | B5 | 2 | 1 | 26 | | PLYWOOD | | GEORGIA PAC. CO. | 0331 | 17 | UP | |
| 17421 | MEDFORD | 15313 | B5 | 1 | 1 | 26 | | PLYWOOD | | OREGON LUMBER | 0342 | 39 | 6 | SP |
| 17212 | | | B5 | 1 | 1 | 26 | | VENEER | | PORTLAND CHEM. | 0351 | 25 | 9 | |
| 17407 | | | B4 | 2 | 1 | 26 | | GROCERIES | | SAFEWAX | 0603 | 41 | 2 | SP |
| 17102 | | | B4 | 3 | 1 | 26 | | FOOD | BH OK | LEMON JUICE CO. | 0613 | 12 | 12 | UP |
| 17194 | | | B4 | 2 | 1 | 26 | | PLYWOOD | | GEORGIA PAC. CO. | 0621 | 27 | 14 | ATSF |
| 16938 | | | B4 | 3 | 1 | 26 | | VENEER | | NORTHWEST LUMBER | 0635 | 09 | 2 | SP |
| 17243 | MEDFORD | 15313 | DF | 1 | 1 | 26 | | BOTTLES | 40FT LENGTH | A & B GLASS CO. | 0639 | 07 | 17 | CB PANH |
| 17271 | MEDFORD | | G4 | 1 | 1 | 26 | | PIPE | | P. FITTER & CO. | 0639 | 28 | 8 | |
| 16854 | MEDFORD | | GC | 1 | 1 | 26 | 130 | GRAIN | | CAL GRAIN CO. | 0643 | 21 | 6 | SP |
| 17011 | GRANTS PASS | 15345 | B5 | 2 | 1 | 26 | | VENEER | | XYZ CO. | 0612 | 12 | 2 | SP |
| 17333 | GRANTS PASS | | B5 | 3 | 1 | 26 | | VENEER | | NORTHWEST LUMBER | 0647 | 20 | 14 | ATSF |
| 17188 | | | B4 | 2 | 1 | 26 | | PLYWOOD | | G.P. LUMBER MILLS | 0611 | 32 | 14 | ATSF |

FIGURE 2-12 CAR ORDER LIST

Supplying Detail Report with Master Report

When the car distributor knows he will want certain detailed lists repeated after the next Master Report, he may indicate this by keying in a special code to the central processor. Then, the detailed report will be transmitted to the high speed printer with subsequent Master Reports.

Short Reports on Typewriter - Inquiry

Certain lists which the distributor will request will be for only a small number of cars. By keying in a special code before requesting the detail list, the distributor will have the option of requesting that these be transmitted directly to his I/O unit.

Inquiries for Car Location

The car distributor, for various purposes, will want to learn the location and disposition of particular cars. He may obtain a brief abstract of the operating record describing the location and status of any car on S. P. lines. This is done using the standard inquiry procedure - entering a code, followed by the car initial and number.

Situation and Turnover Report

This report will be provided once per shift. It is a presentation of operating information, and summarizes the situation turnover reports compiled for key major yards (discussed in "Major Yard Office Section", Output Reports to Local Personnel). The report will indicate the following:

1. Count of cars moved during last shift.
2. Count of cars.
3. Cars delayed.
4. Loading statistics.
5. Summary of dispatcher's calls and estimated schedules.

Control Orders

The car distributor may impose varying degrees of control over the movement of empty cars and the filling of car orders. He can adjust this control for changing local conditions. The TOPS System will aid the distributor by retaining his instructions and automatically checking them against releases of empties, car movement data, car orders, etc., as they are received; exceptions will then be reported to the distributor. These exceptions can be sent to the distributor on a Disposition Monitoring list such as the one shown in Figure 2-13.

| LOCATION | STA. NO. | Q/N | SP ORDER NO. | COMMOD. | SHIPPER | WANTED | | CAR PRESCRIBED | | | CAR USED | | | SPOTTED | | TYPE OF ERROR | |
|-----------|----------|----------------|--------------|----------|--|--------|------|----------------|-----|-------|-----------|--------|-------|---------|------|---------------|------|
| | | | | | | NMBR. | DATE | CAR I & N | Q/N | GRADE | CAR I & N | Q/N | GRADE | DATE | TIME | | |
| TUCUMCARI | 7479 | B5 B4 G4 | 17345 | SOAP | N.M. COMPOUNDS SOUTH CO. POK SCRAP | 1 | 1-24 | MP | B5 | GRADE | KCS | 20774 | BL | GRADE | 1-24 | 07A | KIND |
| | | | 17898 | BY-PROD. | | 1 | 1-24 | SP | B4 | GRADE | ATSF | 74030 | G4 | GRADE | 1-24 | 05A | OPEN |
| | | | 18017 | SCRAP | | 3 | 1-24 | ATSF | G4 | GRADE | SCUP | 773489 | G4 | GRADE | 1-24 | 05A | CAR |
| VAUGHN | 7377 | S4 | 16651 | BUFFALO | GSS RNCH | 1 | 1-24 | SP | S4 | GRADE | 70900 | S4 | GRADE | 1-24 | 11 P | CAR | LATE |

FIGURE 2-13 DISPOSITION MONITORING LIST

The regional and system distributors can impose control by specific types of equipment or by location (by regional or system-wide). A few examples of the possible uses of these types of controls are given below.

Area Control

The distributor may decide that the supply of empties on certain portions of the railroad is so short that he wants to control the movement of all empties in these areas. Accordingly, all empties in the area will be given "hold for distributor" status in yards and on cleaning tracks. The central processor will send all car orders from these areas to the distributor. He may wish to fill some orders himself and assign specific pools of cars to a yardmaster or agent to fill the balance of the orders. Whenever the central processor receives a car movement or disposition contrary to the distributor's instructions, a message will be transmitted to the appropriate major yard office and to the regional distributor, identifying the movement and indicating that it is contrary to standing control orders. If the car has not actually moved, local personnel will correct the move or obtain permission to leave the disposition as it is. If the car has already been moved, the distributor and local personnel will take appropriate action.

Such control will be imposed by entering special control codes into the central processor indicating the degree and type of control desired and the locations involved. In practice, such control would rarely be imposed on just one location. It would more often be used for areas of division size or larger.

The regional distributors, after consulting with operating management and the system distributor, may use such control orders as are necessary for parts or for all of the region.

The system distributor may likewise impose certain control orders which will be broader in nature. Orders imposed by regional distributors will avoid conflict with system control orders.

Special and Short Supply Equipment

Usually, it will not be necessary for a distributor to control all kinds of cars in an area. Control would generally be exerted only upon certain short-supply or special equipment which would be indicated when the "control order" and area codes are entered into the central processor. The familiar order to route all excess box cars to Eugene is an example of this. The central processor will monitor movement data of all box cars and transmit messages to the appropriate yard offices and distributors if empty boxes are moved contrary to these instructions, or if delays occur. Types of special and short-supply equipment which usually would be closely controlled are DF loaders, covered hoppers, double-door box cars, etc. For such cars, a rigid control could be imposed, such as that described in the preceding example. This could be varied and adjusted according to conditions in each region and separate sections of the Master Report would be output for these kinds of cars. With this sort of information and automatic monitoring, several kinds of equipment could be controlled and reported independently of general service equipment.

Exception Control - Assigned Service Cars

Cars in assigned service would generally take care of themselves if the instructions stenciled on them were always followed. These instructions would be placed in the records in the central processor. Whenever such a car is loaded and/or moved contrary to the instructions, the central processor will transmit a message to that effect to the distributor and the appropriate yard office. This control would be exerted only on an exception basis; that is, the distributor is informed only of the deviations from his instructions. Continued monitoring of these cars would not be necessary.

Control of Specific Equipment

Situations will occur in which there will be empties on trains which are not to be switched out before arriving at their destination. These may be box cars moving from Los Angeles cleaning tracks to Eugene, cars prescribed from a yard to an agent on-line, cars being moved by the distributor to alleviate local shortages, etc. In any case, a clearly understood priority procedure must be established for empty cars to effect efficient distribution. This means that cars given specific movement instructions by the distributor are not to be cut out of trains or otherwise moved contrary to instructions. There will be several such types of movement instructions:

1. Prescribing cars for specific car orders or for "hold status" in car pools assigned to groups of orders.
2. Putting cars in "hold for distributor" status.
3. Cars moving from cleaning tracks to other yards.
4. Cars on through freights will be set out at specific points enroute to be applied to car orders on instructions from the car distributor.

The central processor will note in a car's record that the regional or system distributor has given the car's movement instructions. When the car is moved contrary to these instructions, messages to this effect will be transmitted to the distributor and the appropriate yard office. The distributor's movement instruction for empties must have priority over a local instruction.

Filling Car Orders

In many situations, the supply of cars in an area relative to the demand will not warrant any detailed controls by the car distributor. He will establish general movement instructions to be followed, use his reports, and issue occasional specific movement instructions to police these. This procedure will avoid a build-up of excess empties and still maintain a sufficient supply of cars so that agents, yardmasters and conductors can meet orders from the local supply. When a specific type of car approaches short supply, the distributor can impose certain controls, such as those described above, in order to regulate the number of cars available to any location, and so that he can fill some orders himself. He may supplement these controls, of course, by moving cars from other areas, through gateways, etc., as is necessary and possible.

Major Yard Office

When the distributor wishes to fill specific car orders in an area serviced by a major yard office, he simply keys into his I/O unit the car order number, and the initial and number of the car to be used. In many such cases, the car distributor will be filling these orders from lists of orders and cars. He may place the list of orders and the list of cars available side by side and pick a car for each order. The distributor or a clerk will enter this information into the central processor. For each car prescribed, a new yard card will be sent to the appropriate yard office, indicating the destination, spur and spot numbers. Rather than specify particular cars for orders, the distributor could also set up a pool of cars for a group of orders. To do this, he could key into the central processor a list of car initials and numbers and a list of order numbers, or simply instruct the yardmaster to fill a certain group of orders with a certain number of cars of specific types and classifications which are being held in the yard. In the first case, the yardmaster will receive a list of the orders and the cars which will be used to fill the orders. In the second case, the yardmaster will use the cards in his PICL and ISC files to select the cars.

Local Points

In some cases the car distributor will have orders from shippers, or "blanket orders" of one or more cars from agents in areas not serviced by a major yard office. A blanket order will represent the cars the agent feels he needs to fill orders, and will name the agent as shipper. The distributor can supply orders at local points in several ways. From his Master Report and detail lists, he knows what cars are available, and from his consist he knows what empties are moving in trains. As above, the car distributor may assign specific cars to the local orders, or he may wish to fill the order from a supply of cars being held in a yard. He would instruct the yardmaster to move a specific number of cars of each type and classification involved to the agent. As above, the cars he prescribes will agree, as far as possible, in type and classification with those ordered, depending upon the supply of cars available. The distributor would then phone the agent and tell him what types and grades of cars he will receive and when they are coming, so the agent is able to plan their distribution. When the distributor wishes to fill an order at a local point with cars located in a local area not serviced by a major yard office, he will issue work orders to that effect to the proper train crew. He would, again, telephone the proper agent or operator to inform him of the cars prescribed for his orders, or of the use of an agent's cars for orders elsewhere.

When the car distributor or a yardmaster has prescribed cars to fill orders, the central processor will note this in its files; the order will be removed from "order outstanding" status and the car order number will be noted in the car's operating record. However, the order will remain on file until the spotting of the car has been confirmed, as described in the car order procedures. When a pool of cars is assigned to a pool of orders, all the orders will automatically be put on "car prescribed" status, even though no particular car is associated with each order.

When a car has been spotted, the local clerk will enter the spot information into the central processor. When an order is not filled with the prescribed car, the clerk will indicate this condition, or the central processor will indicate it automatically.

In each instance, a message will be sent to the distributor and to the local yardmaster. This will also be noted on the next Master Report and will be available in list form upon inquiry. Given this information, the car distributor will know exactly what happened and can take appropriate action. In some cases, this would involve a direct order to move another car to the spot. In others, it would be understood to be a permissible move under local conditions of shortage, etc. An excessive number of "improper moves" in an area will require bringing the situation to the attention of local operating management.

Referring Car Orders to System Car Distributor

A car distributor may have special car orders in his region for which he has no suitable cars (such as depressed center flats) or insufficient cars. He may refer such orders to the system car distributor who will then assume responsibility for filling the order. The regional car distributor will key into his I/O unit the order number and a special transfer code number which will indicate to the central processor that the system car distributor is to receive all messages and reports about this car order. The system car distributor will assume responsibility for filling the order. The regional distributor will also confirm the order with the system car distributor by telephone.

Conversely, the system car distributor may refer car orders to a regional car distributor.

Cleaning Track at a Major Yard Office

Among the cars sent to a cleaning track for normal reasons will be some sent by the distributor or a yardmaster with specific instructions. These instructions may include:

1. Clean the car and move it to fill a specific order.
2. Upgrade and select for a certain pool of orders.
3. Upgrade and hold for the distributor or yardmaster.

In all cases, the cleaning track personnel will be sent a list from the yard office of all cars on the cleaning track. The cleaning track personnel will mark for each car on the list of cars, the new classification and the order, if appropriate, which has been selected for this car.

The marked lists will be returned to the yard office. A PICL clerk will punch the new classification into the yard cards and enter them into the central processor. He will also transmit cards for those cars prescribed for orders as described in the major yard office procedures. The central processor will update its files and send certain messages to the distributor and/or update the next report for the distributor.

Car Orders from Local Points

In addition to the procedures described on the preceding page, the regional car distributors will enter car order information for certain points. The remainder of this section describes the procedures for accomplishing this.

In many situations, agents on-line can telephone car orders directly to the distributor. For this reason, the car distribution office will have the capability of accepting car orders and monitoring a car order file for agents at certain local points. The car distributor or his clerk will have a supply of numbered car order card forms and will maintain an order file for the local points. The clerk will write the car order information on this form while conversing with the agent on the phone. For each different type of car and commodity the clerk will make out a separate order card, and thus create a separate order. After he has received an order, he will type selected information from the car order including the order number, and will identify each item with a number by placing each on a separate line. The order card is then filed by spur and spot number in the order outstanding file.

Prescribing a Car

When a car is prescribed for an order, the clerk or distributor will key in a code, the car initial and number and the order number. The car initial and number of the car prescribed is noted on the order card which is then filed for reference. If no individual car was prescribed for the order, but sufficient cars from the agent's pool were allocated to a conductor to fill the order, this situation will be communicated to the distributor who will enter only the order numbers into the central processor following a "cars prescribed" code.

When placing a repetitive car order, the agent simply gives the repetitive car order number and the variable data. The clerk will, in turn, write the variable information on a car order card, together with the repetitive car order number, he will then copy, from a list, as much of the repetitive data as he cares to, and enter the variable data and the repetitive order number into the central processor.

From this point, the procedure will be the same as described for regular car orders.

Setting Up and Deleting Repetitive Car Orders

A new repetitive car order can be established by typing the car order behind a repetitive car order code and entering it into the TOPS System.

The central processor will assign a repetitive car order number and transmit this to the distributor's clerk. The clerk will add it to his list of current repetitive car orders. The clerk can delete a repetitive order from his list at any time by entering the "delete repetitive car order" code followed by the repetitive car order number. The central processor will respond with a message confirming the deletion of the order.

Cancelling Orders

When the agent or the patron cancels a car order, the clerk will pull the order card from his "order outstanding" file and key a "cancel order" code and the order number into his I/O unit. If the car had been prescribed for the cancelled order but not yet moved, it will be returned to its previous status. Otherwise, operating instructions will be issued to re-direct the car.

Confirming Car Orders

Wherever local conditions make it possible, the agents will, after cars are spotted, communicate to the distributor which cars are spotted for each order. The distributor or clerk will then key in "confirm orders" code, followed by the order number and the car initials and numbers of the cars used. If these do not agree exactly with the cars prescribed (if any) or the cars wanted (as indicated in the original car order), the central processor will transmit a message to the distributor. If local conditions do not permit this sort of confirmation, the indication that cars have been prescribed will be allowed to stand; that is, it will be assumed that the order was satisfactorily filled unless the agent finds that the patron will not accept the cars prescribed. In that case, he will carry out the "Orders Not Filled" procedure.

Orders Not Filled

When a local agent finds that a patron's order is not properly filled, he will communicate this to the distributor. The distributor will transmit to the central processor an "improperly filled order" code followed by the order number, and re-enter the order indicating the number of cars that are still needed to fill that order.

TABLE OF CONTENTS
FREIGHT TRAFFIC PROCEDURES

| | Page |
|---|------|
| TRAFFIC OFFICE PROCEDURES | 3-2 |
| Inquiries | 3-2 |
| Requests | 3-3 |
| Automatic Reports | 3-4 |
| Administrative Messages | 3-4 |
| Other Data Requirements | 3-5 |
| TRAIN SERVICE BUREAU PROCEDURES | 3-5 |
| Diversions | 3-6 |
| Special Accounts | 3-6 |
| Manifest and Passing Reports to Other Roads | 3-6 |
| SALES AND COST REPORTING PROGRAM | 3-7 |
| EXTENSION OF APPLICATIONS | 3-7 |

FREIGHT TRAFFIC PROCEDURES

The procedures for the applications in the Freight Traffic Department have been designed to exploit the data gathered for the operating and accounting applications from yard offices, freight stations, and junctions throughout the system. This information will be collected while it is still timely, transmitted to the central processor and made available to freight traffic offices and train service bureaus upon request. In some situations, such as bad order set-outs or cars moving for special accounts, messages or reports will be sent automatically by the central processor to the interested traffic offices.

The data stored in the central processor will be accessible through input-output (I/O) units located in 52 traffic offices and train service bureaus; 29 of which are on-line and 23 off-line. Each unit consists of a keyboard and printer and will be connected to the central processor by means of communication lines. The number of I/O units in each office will depend on the level of activity, but will be such that a satisfactory level of service to patrons will be provided at all times. In general, one unit will be sufficient for a traffic office.

All communications between a traffic office and the central processor will be through the I/O units and a printed copy will be made of each message. These local records can be used to monitor the operation as well as provide a means for analyzing the requirements of the patrons.

Normally, an I/O unit will be set to receive information from the TOPS System. When it is used for sending messages to the central processor, it will be switched to input status. However, if a message is ready for transmission to the traffic office while the I/O unit is in the input status, an indicator light will go on to show the operator that a message is being held. The keyboard and printer can be used as a regular electric typewriter when not connected to the TOPS System.

The central processor will contain current operating data for every freight car on Southern Pacific's lines, together with complete revenue waybill information for car-load movements. The operating information will be entered into the TOPS System as soon as it becomes available to the personnel at yards, stations, and junctions. For various procedures this will be as follows:

- | | |
|----------------------------|--|
| For car movements | - after train arrivals and departures. |
| For set-outs and pick-ups | - after the conductor ties up. |
| For bad order set-outs | - after conductor reports to dispatcher or ties up. |
| For back in service report | - after release from mechanical department. |
| For spots and pulls | - after the engine foreman reports in from his zone. |
| For releases | - after notification by the patron. |

Southern Pacific Company

- | | | |
|---------------------------|---|---|
| For interchange received | - | after receipt of interchange list and supporting documents. |
| For interchange delivered | - | after receipt of the list of cars going to interchange. |

If there is a clerk on duty (always the case for larger stations) the information will be entered as soon as it is received. If the clerk is not on duty (as on some branch lines) the information will be entered as soon as he reports to work. Waybill data for local and interline forwarded shipments will be entered immediately after the waybills are typed in the field. Interline received waybills will be re-typed at the junctions for entry into the TOPS System. For intermediate movements, an abstract similar to the present 922 B will be prepared and entered at the junctions.

When a loaded car is unloaded or goes off-line, selected operating and waybill data for that shipment will be retained in the central processor for use by the Freight Traffic Department.

The procedures developed for the traffic offices, both on-line and off-line, are straightforward, because the TOPS System will send information to the traffic offices only when it is needed. Such a system can be developed by having the central processor maintain and search the large files required for car tracing and by having clerks located centrally to control diversions and identify special accounts. By centralizing these functions, the clerical burden in the traffic offices will be reduced, information will be more readily available and close controls will be provided.

TRAFFIC OFFICE PROCEDURES

The procedures for a traffic office can be divided into two categories, those dealing with inquiries for information such as the last reported location of a car and those concerned with requests for service, e.g. a diversion. The response to a car tracing inquiry will be fast, usually only seconds and rarely more than a minute. This means that an inquiry can be received from the patron and processed during a short telephone call. All service requests will be acknowledged to indicate whether the service has been performed or whether it cannot be handled.

All inquiries and requests will be identified by an appropriate code. Each entry into the TOPS System will be made by typing the code followed by the Initial and Number of the car involved and the descriptive information, if there is any.

In addition to replies to inquiries and requests, the traffic offices will automatically receive information on bad-order set-outs, back-in-service notices, and manifest and passing reports for special accounts.

Inquiries

The normal car tracing inquiry, whether the car is loaded or empty, will be for the last reported location. The response to such an inquiry will contain Car Initial and Number, last reported location, train designation, and date and time of arrival or departure from the location. If no information on the car has reached the central processor, a "no record" message will be sent to the traffic office.

Southern Pacific Company

Several other types of car tracing will be provided. If the car has not been received at interchange, an advance tracing request can be made. In this situation, a tracing response will be made automatically as soon as the interchange record is entered into the system. When a loaded car is unloaded or delivered in interchange, the first and last movements for that shipment will be retained in the central processor so that traffic offices can inquire when and where the shipment originated, terminated, or went off-line. Tracing for historical car movements that will not be kept in the TOPS System will be referred to the Auditor of Equipment Service Accounts for processing. Since those requests will be handled manually, an immediate response will not be possible.

Provision has been made to enter the passing information received from other railroads into the TOPS System. In this case, the last reported location will be on a foreign road if the passing has been provided. Otherwise, the response will be the off-going junction or a "no record". This passing information will be received on teletype tape at San Francisco and Houston, converted to cards and entered into the TOPS System.

It will be possible to make a tracing request without a car number by providing the name of the patron and as much additional information as possible. Such a request will be turned over to a Special Accounts clerk, who will scan daily lists containing manifest information sorted by origin state, origin station, on-coming junction and shipper, or lists sorted by destination state, destination station, off-going junction and consignee. Since this is a manual operation, the response will be slow compared to an inquiry using Car Initial and Number. For this reason, car tracing without the car number should not be encouraged.

Information from carload waybills or the abstracts for intermediate shipments covering cars moving under load, will be available to the traffic offices on an inquiry basis. For example, a traffic office could inquire for the manifest description, commodity, routing, shipper, or consignee of any loaded car on Southern Pacific lines.

Requests

The traffic office will be able to make requests to the operating department for services required by patrons. To request a diversion, it will be necessary only to type a code indicating a diversion request, the Initial and Number of the car and the descriptive information such as new destination, new consignee or new routing. This diversion message will be sent to a central diversion clerk for processing. As soon as the diversion has been accomplished or it is determined that it cannot be performed on line, a message will be sent to the originating office.

A request can also be made for an arrival and delivery notice. This request will be retained in the central processor until the car arrives at the destination yard and is delivered to the patron. Messages showing the date and time of arrival and delivery will be sent automatically to the office making the request.

A request to expedite a car will result in the addition of a distinguishing mark such as an "E" to the record for the car on the next and all succeeding advance consists and switch lists. If the car is in a yard when the expedite request is made, a message will be sent to the yard requesting an expedited movement.

A traffic office will also be able to request that a loaded car be held on its behalf. Such a request will generate operating instructions which will move the car to a hold track and will initiate a message to other traffic offices representing the shipper or consignee. Any subsequent movements before the release from hold status has been issued by the requesting office will cause a message to be sent to that office indicating an unauthorized move.

The request for release of the car from hold status will trigger operating instructions which will return the car to normal status and any other traffic offices representing the shipper or consignee will be advised.

Automatic Reports

Immediately after a bad-order set-out is reported, the central processor will determine the traffic offices serving the shipper and consignee and automatically send a message to each identifying the shipment and the location of the car. This message will also include the cause of the bad-order and the estimated delay, if such information has been reported to the central processor.

When the car is reported returned to service, the same traffic offices will be notified immediately.

Each traffic office will provide a central Special Accounts clerk with a list of special accounts indicating those patrons for which manifest information and all subsequent passings are desired, and those for which just manifest information is required. The clerks will use these master lists together with a daily listing of new loads originated and received from connections to identify the movements originated from or destined to special accounts. The car movements identified in this way will be re-entered into the TOPS System and a manifest report will be transmitted to the appropriate traffic offices. The records in the central processor for those cars belonging to patrons that specified continuous passings will be coded so that all the subsequent passings will be automatically transmitted to the proper traffic office.

When requested, the TOPS System will automatically provide a traffic office with manifest and passing reports on loaded special equipment destined for its territory. This information will enable the office to solicit business for the return movement which otherwise would be empty.

Administrative Messages

The off-line traffic offices will be able to use the same I/O unit for administrative messages, inquiries, requests and automatic reports. On-line locations will continue to use teletype equipment for administrative messages until the TOPS System is programmed to switch messages to and from the on-line locations. When this is completed, the teletype will no longer be required and the I/O units will be used for administrative messages. This stage, however, has a low priority in the implementation schedule and will not be reached for several years.

A coded identification of the destination location is essential for automatic switching of an administrative message which originated off-line. If a code is not included, the message will be switched manually. For this reason, each location in the TOPS System that has an I/O unit will be assigned a code number. It will be desirable to use the appropriate code as a prefix to the standard alphabetic description for the destination of the messages whether they originate off-line or on-line. When the operators become familiar with this method of identifying locations, the inclusion of on-line administrative messages in the TOPS System will become possible.

Other Data Requirements

The procedures just described cover the traffic office applications included in the TOPS study. There are additional data requirements which can be divided into two categories:

1. Periodic statistical reports to analyze the volume of business and indicate trends.
2. Current information for sales solicitation.

The first requirement will be satisfied by the Traffic Sales and Cost Reporting Program under development within the Traffic Department. Information for the second category will be supplied in much the same manner as at present. Under the TOPS System, traffic offices will continue to be supplied with copies of waybills, freight bills and selected consists wherever these are required. The switching adverse slips will be prepared locally in accordance with present procedures.

Copies of the lists containing manifest information used to identify special accounts can be air-mailed to interested traffic offices for sales solicitation purposes. In preparing these lists the central processor will inspect each new load originated or received from connections and insert a distinguishing mark beside those that are suspected short hauls.

TRAIN SERVICE BUREAU PROCEDURES

The train service bureaus in San Francisco, Los Angeles, and Houston will process inquiries and service requests and will receive the automatic reports according to the procedures just outlined. In addition, the diversion clerk at Los Angeles will control diversions that are made through his office; the clerk at Houston will handle the Texas and Louisiana lines and the San Francisco Train Service Bureau will process diversions for the remainder of the Southern Pacific system.

The San Francisco train service bureau will also identify all special accounts, handle requests on routings of high-wide-heavy shipments as well as process embargos and quarantine instructions.

Diversions

The central processor will send the diversion request received from a traffic office together with the last reported location of the car to the appropriate train service bureau. There, a clerk will determine the best point at which to effect the diversion. He will enter this information into the TOPS System through his I/O unit. Diversion instructions will then be added automatically to the advance consist containing the car if it has not been sent to the yard selected as the diversion point. If the consist has been transmitted, or if the car is already in the yard, a diversion message will be sent to the yard. When a diversion is accomplished, this fact will be entered into the TOPS System and both the train service bureau and the traffic office will be advised. If a diversion cannot be accomplished at the selected yard, notification will be sent to the diversion clerk who will specify another diversion point and the procedure will be repeated. If a diversion cannot be performed on-line, then the diversion clerk will so advise the traffic office and place a diversion request on the connecting carrier.

The diversion of perishable commodities will be controlled by PFE clerks at 10 locations throughout the system. These clerks will have access to I/O units and will follow the procedures outlined above.

Special Accounts

Once a day, or as often as required, the central processor will produce two lists, each containing manifest information for new loads originated or received from connections. These lists will contain only those shipments eligible for manifesting as designated by the Traffic Department. When each waybill is typed for entry into the system, a notation will be inserted if the movement is not to be manifested.

One of the lists will be sorted by origin state, origin station, or on-coming junction and shipper. The other will be sorted by destination state, destination station or off-going junction and consignee. A clerk will compare these lists with the master special accounts lists prepared by the traffic offices, which will be sorted in the same manner. Any car on the manifest lists that belongs to a special account will be assigned a code indicating the patron, the traffic office and whether subsequent passings should be automatically reported. These codes and an identification of the cars will be entered into the TOPS System through punched cards. Since the cars for one patron should be together in a block on the list, the only data that will be entered will be page number, first line number, last line number, and the special account code.

A copy of the manifest lists will be retained to handle the possibility of a car tracing inquiry without a car number. Other copies will be separated by state and mailed to interested traffic offices for use in sales solicitation efforts.

Manifest and Passing Reports to Other Roads

The TOPS System will continue to supply manifest and passing information to the foreign roads that receive this information at the present time. The central processor will determine the shipments involved by inspecting the off-going junction and analyzing the first part of the route description on the waybill. The manifest and passing

Southern Pacific Company

reports for the identified movements will be produced on cards at San Francisco or Houston, converted to teletype tape periodically, and transmitted to the roads involved.

SALES AND COST REPORTING PROGRAM

The TOPS System will be able to provide in machine readable form (on magnetic tape) most of the waybill information required for the Traffic Sales and Cost Reporting Program. This information can be obtained from the waybill data stored in the central processor either directly, through special programs, or through the accounting codes applied in the Central Rating and Revising Bureau. The rest of the information consists of off-line station codes, AAR identification of destination roads for interline forwarded and intermediate shipments, codes for warehouses loading or receiving shipments for the accounts of patrons, and route codes. This data can be developed through a manual coding operation on the waybills prepared by the Central Rating and Revising Bureau. The codes for each waybill, together with Car Initial and Number and waybill number to identify the shipment, can be punched on a card, converted to magnetic tape and associated with the data available from the TOPS System.

EXTENSION OF APPLICATIONS

If the manual coding required for the Sales and Cost Reporting program was performed in the Central Rating and Revising Bureau at the same time as the accounting codes were applied, there would be no restriction on the reporting period. Consideration could then be given to issuing sales reports more frequently than is presently contemplated. The availability of coded sales data shortly after the waybill is prepared also provides an opportunity for the development of an information reporting system for sales solicitation purposes.

TABLE OF CONTENTS
PROGRAMMING ANALYSIS

| | Page |
|--|------|
| INTRODUCTION | 4-1 |
| IBM 7750 PROGRAMMED TRANSMISSION CONTROL | 4-3 |
| Functional Description of the IBM 7750 | 4-3 |
| TOPS System Parameters | 4-9 |
| Polling Technique for the TOPS System | 4-13 |
| Typical Message Handling Procedure by the IBM 7750 | 4-15 |
| Programming Estimates | 4-18 |
| STRUCTURE OF THE SUPERVISORY PROGRAM | 4-18 |
| Supervisory Program Philosophy | 4-19 |
| Major Functions of the Supervisory Program | 4-20 |
| Program Description | 4-23 |
| DIAGNOSTIC PROGRAMS | 4-27 |
| PROGRAMS FOR THE STANDBY CENTRAL PROCESSOR | 4-28 |
| RANDOM ACCESS FILE ORGANIZATION | 4-29 |
| File Formats | 4-30 |
| Tape Records | 4-35 |
| File Layout | 4-35 |
| EXAMPLE OF A TRAFFIC PROGRAM - TRACING REQUEST | 4-36 |
| EXAMPLE OF AN ACCOUNTING PROGRAM - WAYBILL HANDLING | 4-41 |
| Routine #1 - Waybill Entry Processing | 4-42 |
| Routine #2 - Output Waybill to Tape for Central Rating and Revising | 4-49 |
| Routine #3 - Waybill Revision and Freight Bill Output | 4-49 |
| EXAMPLE OF OPERATING PROGRAMS FOR TRAIN MOVEMENT | 4-55 |
| INITIAL CALL | 4-56 |
| Program Description (Initial Call) | 4-56 |
| INITIAL CONSIST | 4-59 |
| Program Description (Initial Consist) | 4-60 |
| LOCOMOTIVE ASSIGNMENT | 4-63 |
| Program Description (Locomotive Assignment) | 4-63 |
| CREW ON DUTY | 4-66 |
| Program Description (Crew on Duty) | 4-66 |
| DEPARTURE TIME | 4-68 |
| Program Description (Departure Time) | 4-69 |
| DEPARTURE REPORT | 4-71 |
| Program Description (Departure Report) | 4-71 |
| SCHEDULE CONFIRMATION - ADVANCE CONSIST | 4-72 |
| Program Description (Schedule Confirmation - Advance Consist) | 4-73 |
| ARRIVAL TIME | 4-79 |
| Program Description (Arrival Time) | 4-80 |

LIST OF ILLUSTRATIONS

| Figure | | Page |
|--------|--|------|
| 4-1 | Estimates of Program Size and Manpower Required | 4-2 |
| 4-2 | Functional Organization of the IBM 7750 | 4-4 |
| 4-3 | Example of a Message Contained in a Chain of Three Blocks of Storage | 4-6 |
| 4-4 | Channel Word Format | 4-7 |
| 4-5 | Non-Administrative Message Format | 4-11 |
| 4-6 | Administrative Message Format | 4-11 |
| 4-7 | Service Message Format | 4-12 |
| 4-8 | Data Message Format | 4-12 |
| 4-9 | Polling Sequence Flow Diagram | 4-14 |
| 4-10 | Message Handling Procedure of the IBM 7750 | 4-17 |
| 4-11 | Program Description (1) | 4-24 |
| 4-12 | Program Description (2) | 4-25 |
| 4-13 | Program Description (3) | 4-27 |
| 4-14 | File Organization and Cross-Referencing for the TOPS System | 4-31 |
| 4-15 | Program Example - Tracing Request | 4-37 |
| 4-16 | Editing Operation in Core Storage | 4-36 |
| 4-17 | Sample Transmission of Waybill | 4-41 |
| 4-18 | Sample of Input Message in Core Storage | 4-41 |
| 4-19 | Sample Section of a Waybill (AAR 98) | 4-42 |
| 4-20 | Program Description - Waybill Entry into File Record (Routine #1) | 4-44 |
| 4-21 | Image of Waybill in Process Core | 4-43 |
| 4-22 | File Format Work Storage Area in Core | 4-43 |
| 4-23 | Completed W/B File Record Format | 4-47 |
| 4-24 | Format for New Shipments List | 4-48 |
| 4-25 | Program Description - Output W/B to Tape (Routine #2) | 4-50 |
| 4-26 | Program Description - W/B Revision and Freight Bill Output (Routine #3) | 4-53 |
| 4-27 | Program Description - Initial Call | 4-57 |
| 4-28 | Program Description - Initial Consist | 4-61 |
| 4-29 | Program Description - Locomotive Assignment | 4-64 |
| 4-30 | Program Description - Crew on Duty | 4-67 |
| 4-31 | Program Description - Departure Time | 4-70 |
| 4-32 | Program Description - Departure Report | 4-72 |
| 4-33 | Program Description - Schedule Confirmation - Advance Consist | 4-74 |
| 4-34 | Program Description - Arrival Time | 4-81 |

PROGRAMMING ANALYSIS

INTRODUCTION

The programming analysis for the TOPS System was undertaken:

1. To provide information to prove the feasibility of meeting the processing requirements for the applications developed by the field study team.
2. To provide information to determine the size of the central processor and the capacity of the peripheral equipment.
3. To estimate the size of the application programs and the effort required to write and debug them.
4. To determine the functions that will be performed by the IBM 7750 program to link remote I/O units to the central processor.
5. To develop a philosophy for the supervisory program required to control the operation of the central processor.
6. To estimate processing times for an evaluation of the performance of the central processor.

The approach taken to meet these objectives began with a detailed analysis of the application procedures in each of the three areas; Operating, Accounting, and Traffic. It quickly became obvious from early analysis that the requirements for the TOPS System could be met only through the use of random access files. In the operating applications, the central processor monitors the movement of cars and trains and requests required information. To work effectively, such an information control system must have organization that provides equal ease of locating information for any car, train or yard. The central processor will handle most of the clerical burden presently involved in maintaining local records in yard offices by keeping this information in the central processor, and assembling messages and reports for distribution to interested people. Before these records can be removed from the yard offices, it will be necessary for the information in the central processor to be available to local personnel on an inquiry basis; this will be accomplished through the use of random access files. The response required to ensure that the movement of equipment is not delayed precludes batch processing. In the accounting application, many changes and additions must be associated with the original waybill, after it has been prepared. The ability to associate revenue accounting data with the car movement information not only provides tighter control, but eliminates duplication in keypunching and data entry. These associations are most easily formulated with random access files. Furthermore, the fast response to random traffic tracing requests cannot be provided by batch processing.

After the analysis of the procedures, a concept of file organization was developed and the major programs were identified. The formats for input and output messages were established together with the layout of the file records. This information was used to prepare flow charts for all the major applications which would result in distinctive programs.

Critical portions of the flow charts, such as identifying input messages, assigning priorities and reconstructing the waybill image for AAR Form 98, were coded to

Southern Pacific Company

determine the number of instructions and execution times. This information was used as a basis for estimating the number of instructions and execution times for all the flow charts. Finally, estimates were prepared for program size and processing times for all applications.

The estimates were used by the simulation and analysis group to determine the size of the core storage and capacity of required peripheral equipment, and to evaluate the performance of the central processor. The evaluation and programming analysis proved the feasibility of handling the applications of the TOPS System with the central processor specified in the equipment section.

The estimates for sizes of the programs were converted to manpower requirements. The results in Figure 4-1 show 37 man years will be needed to write and debug a total of 96,100 program instructions. This estimate is based on 10 debugged program instructions per day for 254 working days per year. A staff of experienced IBM 7070-74 programmers under the direction of a full time supervisor and co-ordinator was used as a basis for the estimate. An increase in the staff beyond 25 men will not decrease the elapsed time proportionately.

| PROGRAM AREAS | NUMBER OF INSTRUCTIONS | INSTRUCTIONS PER MAN YEAR | MAN YEARS |
|------------------------------------|------------------------|---------------------------|-----------|
| Application | | | |
| Traffic | 8,200 | 2,540 | 3.2 |
| Accounting | 29,800 | 2,540 | 11.7 |
| Operating | 46,100 | 2,540 | 18.1 |
| I/O Control and Tape Specification | 3,500 | 5,080 | 0.7 |
| Disk File Maintenance | 2,500 | 2,540 | 1.0 |
| Message Edits | 6,000 | 2,540 | 2.3 |
| | 96,100 | | 37.0 |

FIGURE 4-1 ESTIMATES OF PROGRAM SIZE AND MANPOWER REQUIRED

The principle relationships between the application programs, supervisory programs, the IBM 7750 program and the diagnostic and standby routines are listed below. The functions of these programs are described later, under separate headings.

1. The IBM 7750 will receive messages from the remote I/O units and send them to the central processor. It will also receive messages from the central processor and relay them to the remote I/O units.
2. The supervisory program will identify the input message as it is received from the IBM 7750 and when the core storage of the central processor is available, it will read the appropriate application program into core storage.

3. The application program will be initialized to core locations assigned by the supervisory program.
4. The supervisory program will transfer the input message to the proper work area before giving control to the application program.
5. When it is necessary to seek a specific file, control will be returned to the supervisory program.
6. The application program will relinquish control only by the issuance of a macro instruction to the supervisory program. This action will occur when the application program requires a specific task, or at its conclusion.
7. In the event of a malfunction, control will be transferred to the diagnostic routines.
8. Standby routines will be used as a conversion from the on-duty central processor to the off-duty one.

The application programming analysis was based on a considerable amount of detail. This information is available for writing the IBM 7074 programs and will result in a considerable time saving. Because of the large amount of detail involved, only samples of the analysis will be shown in this report to illustrate the approach. Representative programs were selected from each of the application areas and are presented later in this section together with a description of the functions and program flow charts.

IBM 7750 PROGRAMMED TRANSMISSION CONTROL MESSAGE EXCHANGE

Functional Description of the IBM 7750

The IBM 7750, a stored program computer, will be used in the TOPS System to control, concentrate, and serialize the flow of data between the I/O units and the IBM 7074. Its major functions are:

1. I/O unit and line control for up to 112 multi-I/O unit half-duplex lines.
2. Serializing characters to bits and accumulating characters from bits. These bits are received or sent through an adaptor to subsets.
3. Accumulating characters into messages or alternately serializing messages into characters.
4. The queuing and transmission of messages to and from the IBM 7074.

A block diagram of the functional components of the IBM 7750 for the TOPS System is shown in Figure 4-2. Explanations of this diagram and some important functional aspects are given below.

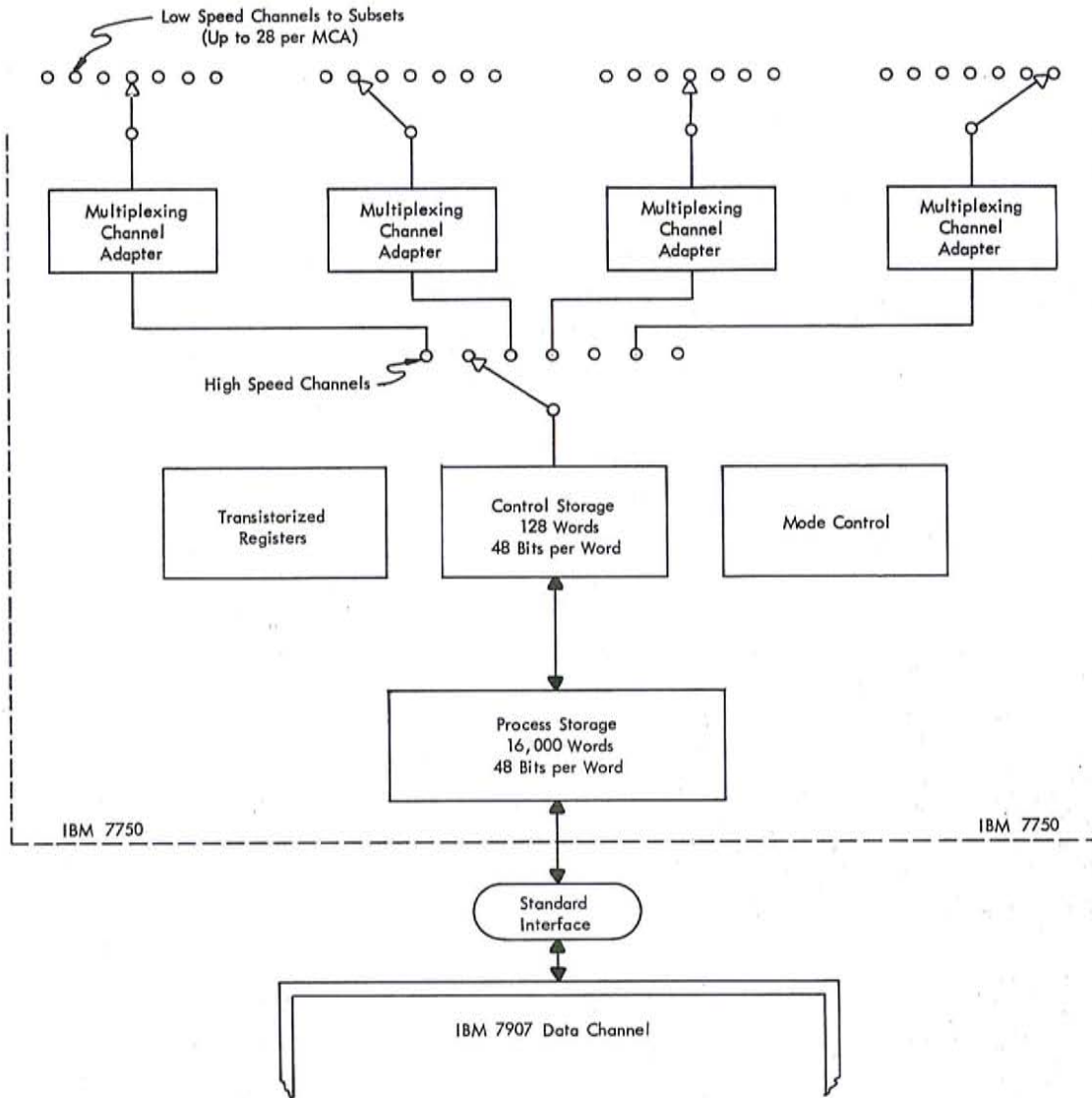

FIGURE 4-2 FUNCTIONAL ORGANIZATION OF THE IBM 7750

Standard Interface

The transfer of data between the IBM 7074 and the IBM 7750 is on a character-by-character basis (serially) through the IBM 7907 data channel and through a standard interface.

Process Storage

This is a core storage array used for the stored program and message queuing. A significant aspect of this storage is that the stored words can be divided into 8-word blocks. Each word in these blocks can be further divided into 4 characters. These characters are individually addressable. The last character of each block (the 32nd) can be used to store the address of the first character of another block of words. Thus, each

Southern Pacific Company

8-word block can be "chained" to another block through the address contained in its 32nd character position. The blocks in storage are positioned in an order that allows the automatic detection of a fixed sequence of low order bits in the binary address of the 32nd character of each block. Upon detection, a branch can be taken to perform one of the following actions:

1. Chain another block to the block now addressed by inserting the address of the first character of the new block into the 32nd character position of the present block. This will add another block to the "chain".
2. Use the contents of the 32nd character position of the present block to address the first character of the next block. This assumes a previously formed chain. The present block may be removed from this chain of blocks to another chain if desired.

When using process storage for message queuing, the chaining technique simplifies storage allocation. The area of process storage allocated to store message data is simply a long chain of available blocks. When storage is needed for a message, the blocks are taken from the available block chain one at a time, and chained together as needed to the message chain. A message may then be scattered throughout storage in a number of 8-word blocks that have been chained together.

Through the use of an "available chain" of blocks, the need for fixed storage allocation for incoming messages, from either the lines or the central processor, is obviated. Variable length messages present no problem. It should be noted that when messages are sent either to the central processor or to the lines, the blocks that compose the "message chain" can be chained to the "available block chain" if their contents are no longer needed.

The control of chaining the blocks together or transferring the blocks from one chain to another is under control of the stored program. This control function is facilitated by the use of a word format in process storage called a limit word, and the inclusion of instructions in the instruction set of modified and indirect addressing.

The limit word contains 3 fields; an address field, a limit field, and a 11-bit field called a "D" field that has no specified function. The address and limit fields are generally used to point to the first and last character of a chain of characters. Figure 4-3 shows a diagram of this concept.

With the use of modified and indirect addressing types of instructions, it is possible to have a table of limit words in memory with each word bounding a message chain. A modifier to an instruction address would pick out the proper limit word from the table, and by use of indirect addressing, would enable the address field of the limit word to be used as the address of the character to be operated upon. If the indirect address field could be incremented, then one instruction could be used to step through a complete message chain, with appropriate branch points for end of blocks. The IBM 7750 stored programs are organized, to a large degree, around the concept of tables, limit words, and data chains. The instruction set includes modified indirect addressing with optional incrementing of the indirect address field. Each entry in the table usually represents a particular transmission line that the stored program is servicing. These tables can be used to identify message chains for a line or can be used to contain a branch address to the sub-routine of the stored program that will be used to service the line at a particular time. An explanation of this technique is given in a later part of this section.

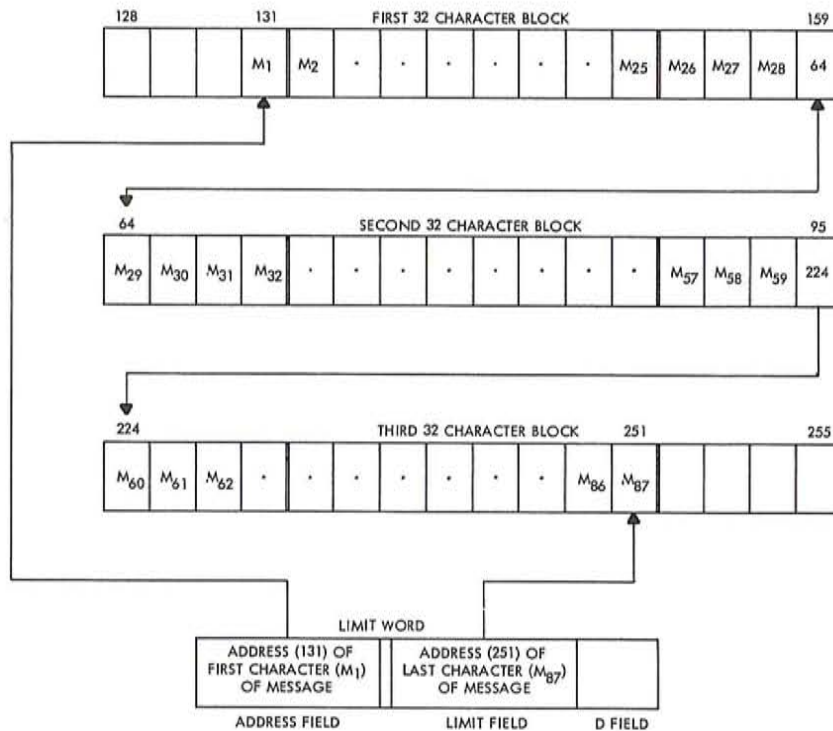

FIGURE 4-3 EXAMPLE OF A MESSAGE CONTAINED IN A CHAIN OF THREE BLOCKS OF STORAGE

The process storage is also used in the usual manner to contain the stored program.

Control Storage

The control storage is a separate core storage array used to perform two functions:

1. Provide operational registers for the stored program on alternate control storage cycles, called "process" cycles.
2. Provide channel words which are used to locate and buffer characters, and provide control bits for the channels or lines that the IBM 7750 is servicing. These words are read out, one at a time, on alternate storage cycles, called "scan" cycles.

The channel word is divided into three fields:

1. A character buffer field.
2. A control field.
3. A character address field.

The format is illustrated in Figure 4-4.

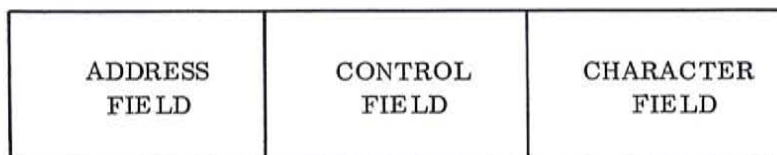

FIGURE 4-4 CHANNEL WORD FORMAT

Groups of channel words are assigned to a particular high speed channel, as shown in Figure 4-2. Sequential scan cycles are allocated to these high speed channels. Thus, if there are 7 high speed channels, every 7th scan cycle is allocated to a particular high speed channel.

On each scan cycle for a particular high speed channel, control storage will read out one of the groups of channel words and allow the multiplexing channel adaptor (MCA) to access its contents. The channel words in a group are read out in sequential order. If there are 7 high speed channels, and 28 channel words assigned to a particular high speed channel, then each channel word in the group would be read out every 196th ($7 \times 28 = 196$) scan cycle.

The channel word's address and control fields are initially loaded by the stored program. Using the address field, the characters that are assembled from the line (receive) are automatically stored in process storage and the address is incremented to the next character position of the block. When the current block is filled, an automatic interrupt occurs and a separate stored program loads the address of the next block of the chain into the address field of the channel word.

When sending data to a line, the characters are automatically obtained from process storage. The address of the next block in the chain is obtained through an automatic interrupt and a stored program.

Multiplexing Channel Adaptor

This unit provides the interface between control storage and the communication subsets for the low speed lines. The major functions are:

1. To present an address to control storage for each scan cycle of the high speed channel assigned to it. This address is used by control storage to read-out a particular channel word from the group of channel words assigned to the high speed channel.
2. To sample the contents of the control and character fields of the channel word being read on the scan cycles, and take appropriate action as determined by the control bits and line parameters which the channel word is servicing.
3. To buffer, time, and transfer the bits of a character between the character area of the channel word and the digital subset.

In summary, the MCA, acting on order from the control bits in the channel words, will send or receive bits from the communication lines at the proper line speed, buffer one bit per line, and then transfer these bits to or from the character fields of the associated channel words.

Mode Control

The IBM 7750 contains a system of automatic interrupts of fixed priority. These automatic interrupts are called modes. The stored program of the IBM 7750 is comprised of 5 distinct programs, one for each of 5 modes. A 6th mode has a routine designed into the machine logic. These modes and their functions are described below, and are listed in order of priority - (highest to lowest).

1. Service Mode - This mode is used for error conditions in the circuits of the IBM 7750. Diagnostic routines may sometimes be written in this mode.
2. Channel Service Mode - This mode is used to connect blocks whenever a channel word has reached the 31st character position of a block while obtaining or storing characters from process storage. The mode is automatically entered whenever a channel word's address field is stepped to the 32nd character position of a block. The stored program allows the loading of the address for the first character of the next block in the message chain into the address field of the channel word (sending), or allows chaining a new block to the current one and putting its first character address into the address field of the channel word (receiving).
3. Copy Mode - In this mode the IBM 7750, by design, automatically transfers data character-by-character through the standard interface. The Copy Mode is initiated by the "In" or "Out" mode which defines the data to be transferred. The data is defined by a limit word called the Copy Word.
4. Out Mode - This mode is used to set up the Copy Word and controls necessary to transfer into Copy Mode and transfer data from the IBM 7750 to the central processor. It can be initiated by the central processor or any of the stored programs in the IBM 7750 in any of the modes. It is usually initiated by the Normal Mode of the IBM 7750.
5. In Mode - This mode has the alternate function of the "Out Mode" in that it sets up the Copy Word and the controls necessary to transfer data from the IBM 7074 to the IBM 7750. It is usually initiated by the IBM 7074.
6. Normal Mode - This mode performs most of the stored program functions in the IBM 7750. The other modes, although of higher priority, are essentially performing bookkeeping functions for the normal mode automatically. This relieves the programmer of writing into his normal mode program any monitoring and interrupt instructions needed to perform the bookkeeping functions.

The normal mode program performs most of the functions normally associated with the IBM 7750. It initiates and monitors messages sent to and received from the IBM 7750. It controls and checks message

transmission, monitors queues, controls polling techniques, edits messages for formats, control characters, etc..

The essential philosophy behind normal mode programming is a machine speed that is an order of magnitude greater than line speed. The speed difference allows a stored program to monitor and control many similar lines in a sequential order. As each line may be in a different program sequence on any sequential "scan", a technique must be synthesized to allow a branch point in the program sequence for each transmission line. The technique employed in the TOPS System is one for which the IBM 7750 was specifically designed and organized. It employs a table of limit words with one word for each line. A program branch address is stored in the address field of the limit word. The address identifies the instruction to be used in the program scan for the next service of a particular line. When the stored program has monitored and performed any needed action for a line, it stores in this Program Branch Table the address of the next instruction to be used for monitoring and performing those parameters that the line will present in the next sequential "scan". The program then goes on to the next entry in the Program Branch Table and performs the necessary service for the next line. In this manner the program is continuously, and sequentially, servicing all lines. It should be realized that all other modes of operation in the IBM 7750 interrupt the execution of the Normal Mode Program. These interrupts are generally initiated automatically. The Normal Mode Program, generally, neither initiates or knows when the interrupts are occurring, or how much time they will use. Its efficiency, however, is very much influenced by the time taken by the other mode programs. For this reason, much effort is concentrated into making the programs as sophisticated and fast as possible.

7. Registers - The 7750 has several registers to execute the automatic and stored program functions.

TOPS System Parameters

Because the IBM 7750 is a stored program machine, it has an inherent flexibility to service an almost infinite number of combinations of system parameters. The following discussion defines the specific parameters of the TOPS System.

Lines and I/O Units

1. Half Duplex Lines.
2. Start - Stop Transmission.
3. BCD Code.
4. LRC checking with 2 retransmissions for transmission errors.
5. Multi-I/O unit lines with polling selection control.
6. No interrupts of messages required.

Southern Pacific Company

7. Output from the IBM 7750 to I/O units will only be to the printer and the card punch.
8. For a transmission error, the data will be transmitted three times, and then other corrective actions will be taken.
9. There will be automatic capabilities and procedures within the I/O units to handle transmission errors. These capabilities and procedures are:

Card Reader - If the data on a card are transmitted in error, the card reader will automatically re-read the card.

Paper Tape Reader - If the data on paper tape are transmitted in error, the paper tape reader will automatically rewind to the last LRC character.

Card Punch - Data received incorrectly by the card punch is recognized by an LRC error after punching. The error causes the data to be retransmitted and punched in the next card. There is one LRC per card.

Printer - If data are not received correctly by a printer, the line printed in error will be identified and a retransmission will be started on a new line. The technique used may be program controlled. The LRC check on the output to the printer is on a line basis.

Message Formats and Size

1. Between 7750 and I/O Units:

The input messages to the IBM 7750 from the I/O units can be of variable length. Their size will vary from approximately 15 to 4500 characters.

The IBM 7750 classifies all input messages as either administrative or non-administrative. Non-administrative messages are always sent to the computer while the administrative messages will be transmitted to the IBM 7074 only in cases of momentary overload of the IBM 7750. Each administrative message will be interrogated for destination addresses. If the destination is for one of 23 particular off-line traffic I/O units, the IBM 7750 will send the administrative message to its destination. If the destination is to any other location, the IBM 7750 will send the administrative messages to the existing teletype center for further routing.

The input message formats, excluding control characters, are shown in Figures 4-5 and Figure 4-6.

| | |
|------------------------|-------------------------|
| MESSAGE TYPE (a) | MESSAGE CONTENTS (b) |
|------------------------|-------------------------|

FIGURE 4-5 NON-ADMINISTRATIVE MESSAGE FORMAT

- (a) A four character field that indicates message type. It will never start with an "A".
- (b) The message field will vary in length. It will be interspersed with control characters that are needed for I/O unit control, and transmission checking.

| | | |
|------------------------|-------------------------|-------------------------|
| MESSAGE TYPE (a) | ADDRESS FIELD (b) | MESSAGE CONTENTS (c) |
|------------------------|-------------------------|-------------------------|

FIGURE 4-6 ADMINISTRATIVE MESSAGE FORMAT

- (a) A four character field that indicates message type. It will always start with an "A".
- (b) The address field will consist of as many two-character mnemonic characters as there are destinations for the message. An example might be SF (San Francisco), LA (Los Angeles), etc. The address field will be separated from the message field by a special character.
- (c) The message field has the same definition as non-administrative messages.

2. Between 7750 and 7074:

Because very long messages can be received from or sent to the I/O units, the IBM 7750, when receiving messages from the lines, will divide them into partial messages consisting of a specified maximum number of LRC-bounded groups. This will result in a message length, generally of 50 to 200 characters, for messages to be sent to the IBM 7074. For transmission from the IBM 7074 to the IBM 7750, the maximum message length is 495 characters.

Messages to be sent between the IBM 7750 and the IBM 7074 are of three basic types:

- 1. Data messages (messages containing data) received from the I/O units or the IBM 7074.
- 2. Administrative messages when the IBM 7750 is overloaded.
- 3. Service messages or messages used to indicate an unusual condition in the system to the IBM 7074.

The general formats for messages transmitted between the IBM 7750 and IBM 7074 are shown below:

| | | |
|-------------------------|------------------------|-------------------------|
| ADDRESS FIELD (a) | MESSAGE TYPE (b) | MESSAGE CONTENTS (c) |
|-------------------------|------------------------|-------------------------|

FIGURE 4-7 SERVICE MESSAGE FORMAT

- (a) Address of particular line, I/O unit or component effected by the message.
- (b) A four character field that indicates message type; the field will contain a service message designation.
- (c) The message field, variable in length, will contain the information to be conveyed by the service message.

| | | |
|-------------------------|------------------------|-------------------------|
| ADDRESS FIELD (a) | MESSAGE TYPE (b) | MESSAGE CONTENTS (c) |
|-------------------------|------------------------|-------------------------|

FIGURE 4-8 DATA MESSAGE FORMAT

- (a) Address Field:

Address of the particular originating line, I/O unit or component messages from the IBM 7750 to the IBM 7074.

A multiple address field for a message going from the IBM 7074 to the IBM 7750 designating each line, I/O unit or component which is to receive the message. In the case of multiple addresses, each one will be separated from the others by a special character.
- (b) Message Type:

The message type is only needed for messages going from the IBM 7750 to the IBM 7074 (not 7074 to 7750). The message type indication for a partial message to the IBM 7074 may only be a one character designation rather than the previously mentioned four character designation.
- (c) Message:

Of variable length and containing the actual data of the message. The message field will be terminated by special characters that indicate whether or not the message is complete or partial.

Polling Technique for the TOPS System

The polling technique for the TOPS System is based upon several parameters:

1. A one minute response for the 90th percentile is needed for all manifest and tracing requests.
2. A fifteen minute wait time for the 90th percentile is needed for operational inputs.
3. The wait time for waybill input is arbitrary; that is, a waybilling and transmission set need not be serviced for over 15 minutes. A wait of hours is allowable if the system is overloaded.
4. The individual components within an I/O unit can be independently polled or selected.
5. Administrative messages will not be handled completely within the system, and their response time is somewhat arbitrary.
6. Off-line capability for I/O unit components.

The above parameters led to the development of the polling routine shown in Figure 4-9.

A description of this routine on a per line basis is given below:

1. If possible, all messages per line received from the IBM 7074 will be outputted by the IBM 7750. The off-line capability of the I/O unit may not allow outputting of all messages queued in the IBM 7750.
2. Following the outputting of all messages to a line, the IBM 7750 will poll all high priority units on that line in a fixed order, determined by a stored table in the IBM 7750. Only one message per unit will be received in this sequence.
3. If any of the units polled in (2) above had a message to send, the 7750 program will branch back to (1) after the poll table has been sequenced through one time. This process will continue until all messages from the 7074 have been sent and all high priority I/O's have been polled.
4. When all messages are sent and all high priority I/O units are polled, the IBM 7750 program will check to determine if any administrative messages are to be sent on this line. It should be noted that in the initial stages of the System this will be true only for particular lines. If an administrative message(s) is (are) queued for the line, then one message will be sent out, and the IBM 7750 program will then branch back to (1). If there is not an administrative message for the line, the IBM 7750 program will branch to (5) below.
5. If all conditions noted above are met, a waybilling and transmission set will be polled. The addresses of the sets on each line will be stored in a fixed table in the IBM 7750 called the low priority poll table. The IBM 7750 will poll through the table in a fixed order until one of the units responds with a message. After a message is received or no unit responds with a message, the 7750 will branch to (1) above.

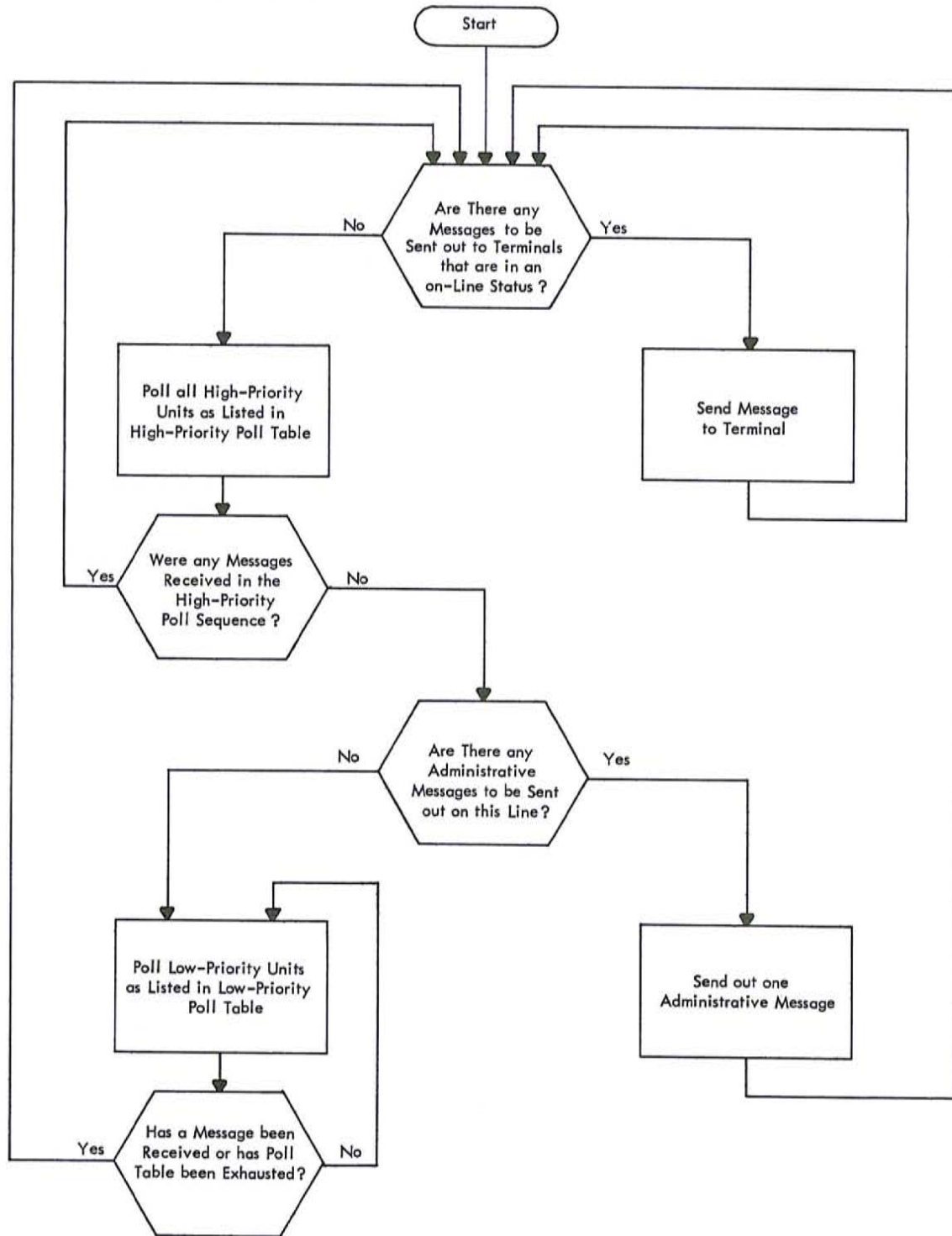

FIGURE 4-9 POLLING SEQUENCE FLOW DIAGRAM (On a Per Line Basis)

Typical Message Handling Procedure by the IBM 7750 in the TOPS System

Message from an I/O Unit to the IBM 7074

The following example is a typical account of how a message originating from an I/O unit on the Southern Pacific System is handled while enroute through the IBM 7750 to the IBM 7074.

Each of the input components within an I/O unit complex is periodically polled by the 7750 according to a pre-determined polling procedure. During the procedure, each component is addressed by its unique I/O unit - component address. A component being polled is, essentially, asked whether or not it has a message to send and is expected to reply to the poll by automatically sending the first character of the message, or indicating to the IBM 7750 that no message is waiting to be sent. Assuming there is a message waiting, the I/O unit will proceed to send it on the communication line, bit by bit (serially).

As a check on an erroneously transmitted character, an LRC (longitudinal redundancy check) character will be generated by the I/O unit and sent as the last character of each group of data characters. Further mention of the LRC character will be made later in this discussion.

When received by the IBM 7750 via the communication line and Multiplexing Channel Adaptor (MCA), the bits will be assembled into characters, and automatically placed in a sequential location of a block in core storage. Additional blocks are made available as needed by the channel service mode. Even as the characters are being assembled and stored, the IBM 7750 Normal Mode program will begin re-accessing each character and examining it for control implications and LRC generation.

When it receives a message, the IBM 7750 first determines the message type; this may be either administrative or non-administrative. The administrative messages are handled in a slightly different manner in that their defining limit words are stored by themselves in an open end chain; the messages are not broken into partial messages as are non-administrative messages.

When a group of data characters and its associated LRC character have been received, a comparison is made between the received LRC character and an IBM 7750 generated LRC character. A favorable comparison indicates that the previous group of data characters is free from error. If the compared LRC characters are not identical, the erroneous group of characters is erased and the I/O unit is requested to retransmit that portion of the message. A maximum of two retransmissions is allowed before more serious error notifications are made. Assuming that the LRC comparison is favorable, the I/O unit will either transmit the next block of data of the message, or end the transmission if the message is complete.

As the message groups within a message are received by the IBM 7750, a count of the number of characters received is maintained. If the count exceeds a pre-determined maximum, a partial message of the received data characters is prepared for transmission to the central processor. If the end of the message occurs before the predetermined character count is reached, the entire message is prepared for transmission to the central processor.

Southern Pacific Company

The complete or partial messages that are to be sent to the central processor are edited for proper format and identified by limit words. The limit words, identifying each complete or partial message, are then queued in a table of limit words.

If, upon completion of a line scan, there are any complete messages or partial messages queued in the table of limit words, the IBM 7750 will notify the central processor to initiate Out Mode. When the first message or partial message has been transmitted to the central processor, the IBM 7750 will revert to Normal Mode. If there are more complete or partial messages queued in the table, the IBM 7750 will again revert to Out Mode and send the next message in sequence as a separate transmission until the entire table of messages has been emptied.

Message from an IBM 7074 to an I/O Unit

The following example illustrates how a message is transferred from the IBM 7074 to an I/O unit. (See Figure 4-10)

When the IBM 7074 has messages to be sent to I/O units, it transfers the messages and their destinations to the IBM 7750 by initiating the In Mode. Once the transfer of data is completed, the IBM 7750 will go back to Normal Mode, edit the received messages and insert the timing, control and LRC characters. The messages are defined by limit words and are queued in a table with access to each message by a line index. Usually, no more than three messages per line are queued.

In the Select Routine (sending messages to I/O units), the IBM 7750 will sample the message tables to determine if any messages are queued for output to a line. If a message is in the table, the IBM 7750 will select the I/O unit (s) to which the message is to be outputted. If the selected units are ready to accept data from the line, the I/O unit will signal the IBM 7750 that the message can be outputted. If the units are busy in a local job, the I/O unit will signal the IBM 7750 that the message cannot be accepted at this time.

In the case where the units are busy in a local job, the IBM 7750 will transfer the limit word defining the message to a special chain of limit words that define messages destined for I/O units that are busy in local activities. A count is kept of the number of times the IBM 7750 has attempted to send the message. When a predetermined count is reached, the message will be sent to the data central I/O unit.

In the case where the units can accept the message, the IBM 7750 will insert the address of the first character of the message chain into the address field of the channel word servicing the line. The fetching of characters from process storage into the character area of the channel word is automatic, as is the serializing of characters into bits by the MCA. When a block of characters within the message chain has been completed, the Channel Service Mode will be initiated and the address of the first character of the next block in the chain will be inserted into the address field of the channel word.

Once the IBM 7750 Normal Mode Program has initiated the transmission of a message to an I/O unit, as described above, the program will branch to service the other lines as described in the Normal Mode description.

Southern Pacific Company

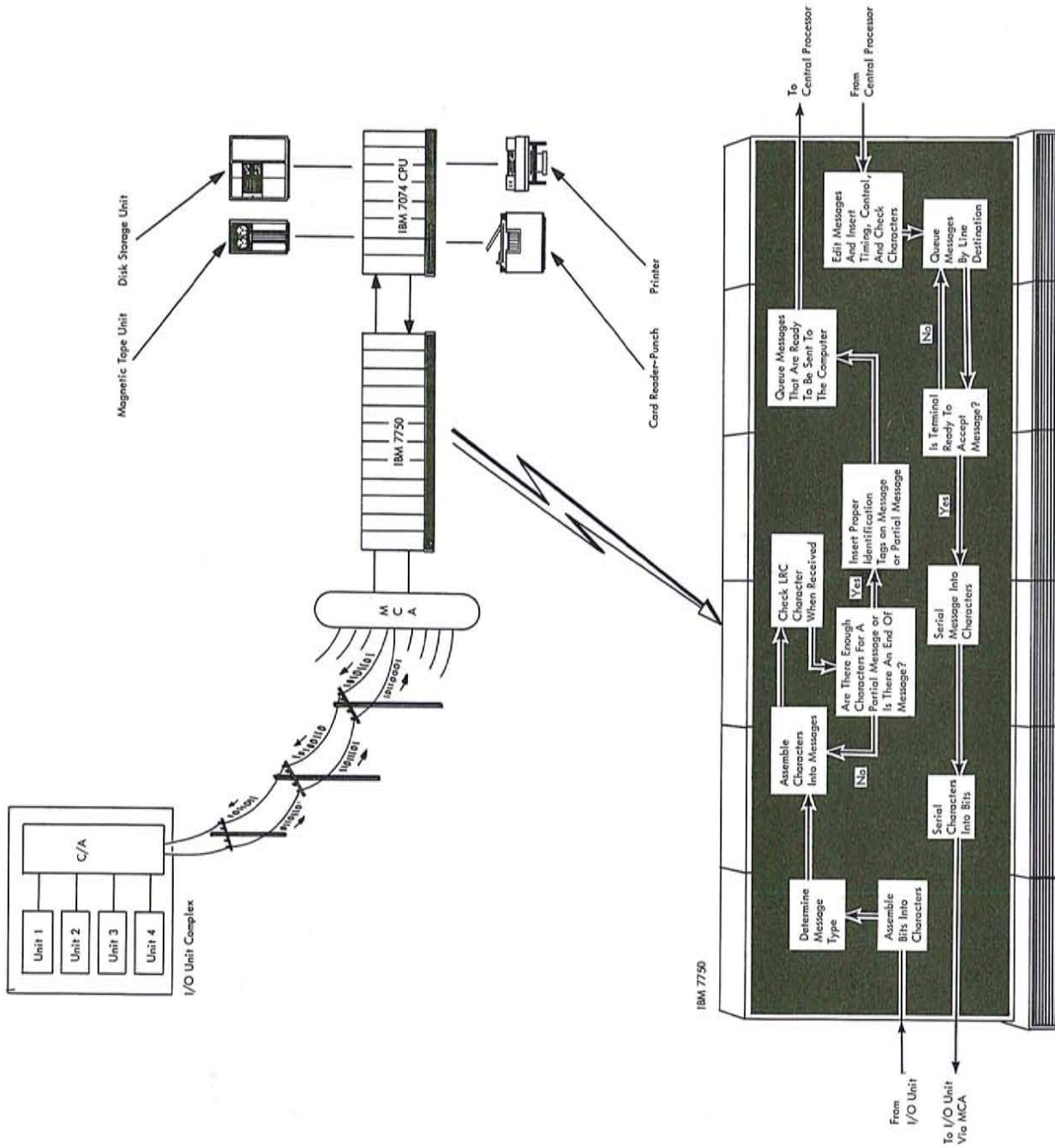

FIGURE 4-10 MESSAGE HANDLING PROCEDURE OF THE IBM 7750 FOR THE TOPS SYSTEM

The I/O units receive the characters and generate an LRC character for the data received. When a transmission is to be checked, the I/O unit-generated LRC and the IBM 7750-generated LRC are compared. If the data were not transmitted correctly, as indicated by an unfavorable comparison, the IBM 7750 Normal Mode Program, which has been periodically auditing the transmission, will retransmit the data up to two times. If the data transmission was correct, as indicated by a favorable comparison of the LRC character, the next group of characters will be transmitted. This process will continue until the entire message has been sent out.

The IBM 7750 will retain the entire message in its core storage until it has been completely and correctly transferred to the I/O unit. If a correct transmission is impossible, the message will be sent to the data central I/O unit.

Programming Estimates

An extensive analysis of the IBM 7750 was undertaken to determine the core storage requirements and the feasibility of handling the specified parameters of the TOPS System. Although it is recognized that many aspects of this analysis will change as the system progresses, it is felt that the analysis does prove feasibility, and does give a fairly close estimate of the core storage and programming requirements.

From the analysis it is estimated that 6 to 7 thousand words of core storage will be needed for instructions and tables. The estimate includes such parameters as future growth in administrative message handling, error routines and communication messages for control purposes between the IBM 7750 and the IBM 7074, and the I/O unit at the data central. With this storage requirement for the program, the total core storage space for the IBM 7750 in the TOPS System should be 16,000 words.

STRUCTURE OF THE SUPERVISORY PROGRAM

The supervisory program co-ordinates the over-all processing functions of central processor. Specific processing jobs are controlled by an application program designed for that job. Because of the various application programs required, all processing functions that are common to any processing job are controlled by the supervisory program. The supervisory program, therefore, is used frequently and for a variety of reasons. Any part of the system can call the supervisory program when there is need for it. Ways in which the supervisory program can be activated are listed below:

1. It can be entered as a direct result of obeying an application program. A program being executed calls for the supervisory program whenever it requests an action that is subject to control by the supervisory program, such as a request for transfer to or from peripheral equipment or the information of transfers between core storage and disk files.

2. The supervisory program may be activated by various units which have completed their assigned tasks and require further attention.
3. Certain failures of peripheral equipment call the supervisory program into action.

The central processor shares its time between the supervisory program activities and the execution of the application programs. The supervisory program consists of many branches that are normally dormant, but which can be activated whenever required. The sequence in which the branches are activated is essentially random, being dictated by the application programs and the functioning of the peripheral equipment.

Supervisory Program Philosophy

The supervisory program for the TOPS System makes possible the processing of many different input messages on a basis of unit sharing and time sharing of the central processor. Because of the intermixing of program executions, the rules for programming in this system differ from those for a standard data processing system. The supervisory system consists of a set of inter-related sub-routines which handle:

1. Memory allocation.
2. Input-Output control.
3. Priority of programs.
4. Queuing of work to be done.
5. Error checking.
6. Operator communications.
7. Inter-computer communications.

Considering the functions outlined above, the basic task of the supervisory program becomes the maintenance of lists containing jobs to be performed by various programs and/or units. Items are added to the lists containing work for input-output units upon demand by the application program; items are deleted from these lists at the completion of the data transfer. Items are added to the central processor lists on arrival from an external source; they are also added when a job that has been deferred while waiting for the completion of a peripheral operation becomes ready for further processing.

Thus, a basic characteristic of the supervisory program is the ability to move items from one list to another, or to enter or delete items from lists upon demand from an application program, or upon a signal from the central processor. Another characteristic of the supervisory program is its ability to cause these lists to be serviced (by control) with a pre-assigned priority, thus giving various kinds of tasks precedence over others.

There are four basic categories of the supervisory programs:

1. Programs that search lists for CPU processing jobs to be done, delete them from the list in which they are found and give control to the appropriate sub-program.
2. Programs that add items to the lists containing jobs to be done by the central processor or one of the various input-output channels.
3. Programs that delete jobs from the lists containing work to be done by input-output channels when the work is completed (and start the next item in the list). When all input (or output) waiting for this particular job is complete these programs may add this job to the list containing jobs to be done by the central processor.
4. Programs that fall into an area between Operational and Control, have as their functions the extension of some other basic supervisory program. They function in the same framework as an application program and are subject to similar restrictions.

Therefore, it would be most correct to refer to a set of supervisory programs rather than a single supervisory program. Some of these programs (the macro programs) can be thought of as subroutines of the application programs while the CPU Loop Program can be considered as the main program to which all application programs are subroutines. This is pointed out specifically to show that when control of the central processor is transferred to an application program it retains complete control of the processor (except for input-output channel interrupts) until it executes a return to one of the supervisory programs. It may use some of the supervisory programs (macros) as subroutines, but still retain control of the "main" program during this time.

Major Functions of the Supervisory Program

The major functions of the supervisory program are:

1. Core Storage Allocation - Control all uncommitted core storage locations and assign core storage as requested by the application programs. The supervisory program keeps track of the amount of available core storage as requested by the application programs. The supervisory program keeps track of the amount of available core storage and takes appropriate action when this amount becomes critical.

Storage is divided into permanent storage and working storage. Permanent storage is the area of storage that is used by programs which are permanently located in the central processor (control and supervisory programs). It also includes any data, constants or tables that are permanently kept in core storage. This area is assigned at system setup time and is not controlled by the supervisory program. Working storage is divided into single file record blocks and is used for all data requirements, such as input messages, programs not normally in core, file records, etc. The supervisory program maintains a list of uncommitted blocks. In standard operation, these blocks

are required for input operation or as a result of input requests by the application programs and are released upon request of the application programs.

2. Input-Output Control - The supervisory program has control of input-output operations, usually upon request of the application programs. All input-output operations are executed by the supervisory program. For this purpose, control must be returned to the supervisory program before input-output requests are initiated. These requests are completed before processing continues on the message. The application programs provide the unit address of the data to be transmitted at request time. There are several "Request Words" available to the application program for communication purposes with the supervisory program. Its contents include the nature of the request and the working core storage location referred to. Associated with each Request Word is the address of the peripheral unit through which the request is made. When an application program transfers control to the supervisory program, the request words are tested and any input-output requests to be made are placed in a waiting list associated with the unit through which the request is being made. Upon completion of an input-output request, the Entry Block making reference to this request is noted. The last input-output request to be completed for a particular entry causes the supervisory program to place the reference to the Entry Block in a waiting list to wait further processing by the supervisory programs.
3. Priority of Processing - The applications developed in the TOPS System and the equipment capabilities are such that there can be many simultaneous requests for CPU time. The supervisory program, therefore, must setup waiting lists for processing. The waiting list is based on the importance of an operation and on the completion of file requests. The basic loop of the supervisory program is one that checks the conditions of the various CPU waiting lists to determine what jobs, if any, are waiting for attention by the CPU. This list is composed of entries that are placed there by the interrupt programs on one of the data channels. Entries are deleted from this list by the supervisory program which, upon finding an entry in the lists, transfers control to the central processor application program specified in the entry. Control remains with the application program until it transfers back to the supervisory program. Control may be seized by an interrupt program that is triggered by the completion of an input or output operation.

The CPU Waiting List consists of three basic lists whose separate existence is based upon the priority in which they should be processed. The highest priority is at the top of this family of waiting lists. Upon return to the supervisory program from an application program, the supervisory program begins interrogation of the list from the top priority down.

4. Queuing of Work to be Done - One of the basic functions of the supervisory program is to maintain the lists of jobs to be performed by the various programs and units. In general, items are added to a list of

work for peripheral units on demand by the application program; items are deleted from these lists upon completion of the data transfer.

Items are added to the CPU list on arrival from an external source. They are also added when a job that had been deferred while waiting for the completion of a peripheral operation becomes ready for further processing.

A "list" is a series of core storage blocks which are connected by control words. There are normally two control words associated with each block; one specifies the location of the next control word in the list and the other specifies the location of the core storage block with which the control words are associated. Two core storage blocks sequentially listed may or may not be contiguous in core storage. Each list has two control words associated with it; one indicates the location of the first block and the other indicates the last. The lists are changed during processing; the normal procedure is to delete from the top (first item) of the list and to add to the bottom (last item).

5. Error Checking - All transfers of data from disk storage to core storage are checked and if a failure occurs the attempt to read is repeated a number of times. On repeated failures, an alternate path to the data is chosen. All transfers of address information to and from the disk files are parity checked.

If it is impossible to read or write a file record due to equipment errors, a notification is printed and control is returned to a special application program. The special application program will send an error message to the I/O unit concerned. Non-equipment errors are returned to another application program for appropriate action.

A special non-stop interrupt feature is planned for the TOPS System. This feature allows the central processor to be interrupted whenever a machine error occurs that normally stops the central processor. With this feature, a transfer can be made automatically to a routine that will analyze the instruction being executed or attempted and take appropriate programmed action.

6. Operator Communication - The supervisory program will communicate with the operator through a standard I/O unit and provide pertinent information when necessary or when requested by the operator. The operator may also inform the supervisory program of such things as the real time, system configuration change, computer change-over, etc.
7. Communications Between Active and Stand-by Processors - The supervisory program will provide the facility for the two supervisory programs (one in each system) to communicate with each other. This communication will be limited to that required for file control and switch-over procedure. In the event of an operator request for switch-over, the active supervisory program will prepare the central processor for the switching operation. Upon request of

the operator or the active supervisory program, the stand-by supervisory program will prepare to assume the tasks of the TOPS System. The supervisory program assumes that the stand-by processor contains the basic supervisory program.

The supervisory program will also supervise the running of short diagnostic routines during non-peak periods. At the completion of each routine, control will be returned to the supervisory program and if no messages are to be processed additional routines will be executed. The running of diagnostics will be periodic and not a continuous process.

Program Description

When an input message is to be sent to the central processor, the supervisory program checks to determine if a minimum number of core storage blocks are available. If the minimum number of blocks are available, the supervisory program services the input request. A block or blocks of core storage is obtained and the message is read into storage. Before obtaining a block of core storage, all interrupts, except the error interrupt, are disabled. This is necessary to ensure that a program operating in the Priority Mode does not remove the same block assigned to a different entry block. After obtaining a block of storage, the list of available core storage is re-chained and the counter of available storage blocks is decremented. Some of the input messages will be assembled and stored temporarily on the disk files to await processing.

After the complete message has been received, a table look-up operation is performed to obtain the address of the application program that will process the message, the core storage requirements of the application program, etc. If the application program is not in core storage, the supervisory program initiates the process of obtaining the program from file storage (refer to Figure 4-11). Once the application program is in core storage, the supervisory program turns control of the message over to the application program.

The structure of all of the application programs is such that they request references to the disk files. These requests are handled via supervisory program macros. The philosophy of the application program in most cases, dictates handling the processing of a message until the file request is completed. If the requested module is busy when the file request is issued, the request is placed in a queue. At the completion of file requests, the queue is checked and the request is executed. (Figure 4-12). When the file request is completed, the message is placed on a waiting list (Figure 4-12) for further processing. The waiting list is part of the basic loop of the supervisory program. Also a part of this loop are the other waiting lists, CPU Work List (items ready for processing) and the Input Ready List (items from the input device that are complete and may or may not have their application program in core storage). The alarm device (a time controlled device that, if not reset, gives an indication that something is wrong with the program or equipment) is also a part of this basic loop. The loop also contains the provision for updating the application time for the system.

Another of the functions of the supervisory program is to release core storage blocks when their usefulness has expired (Figure 4-13). This occurs at the completion of a file write operation, an output to the I/O equipment, or at the completion of processing a message.

Southern Pacific Company

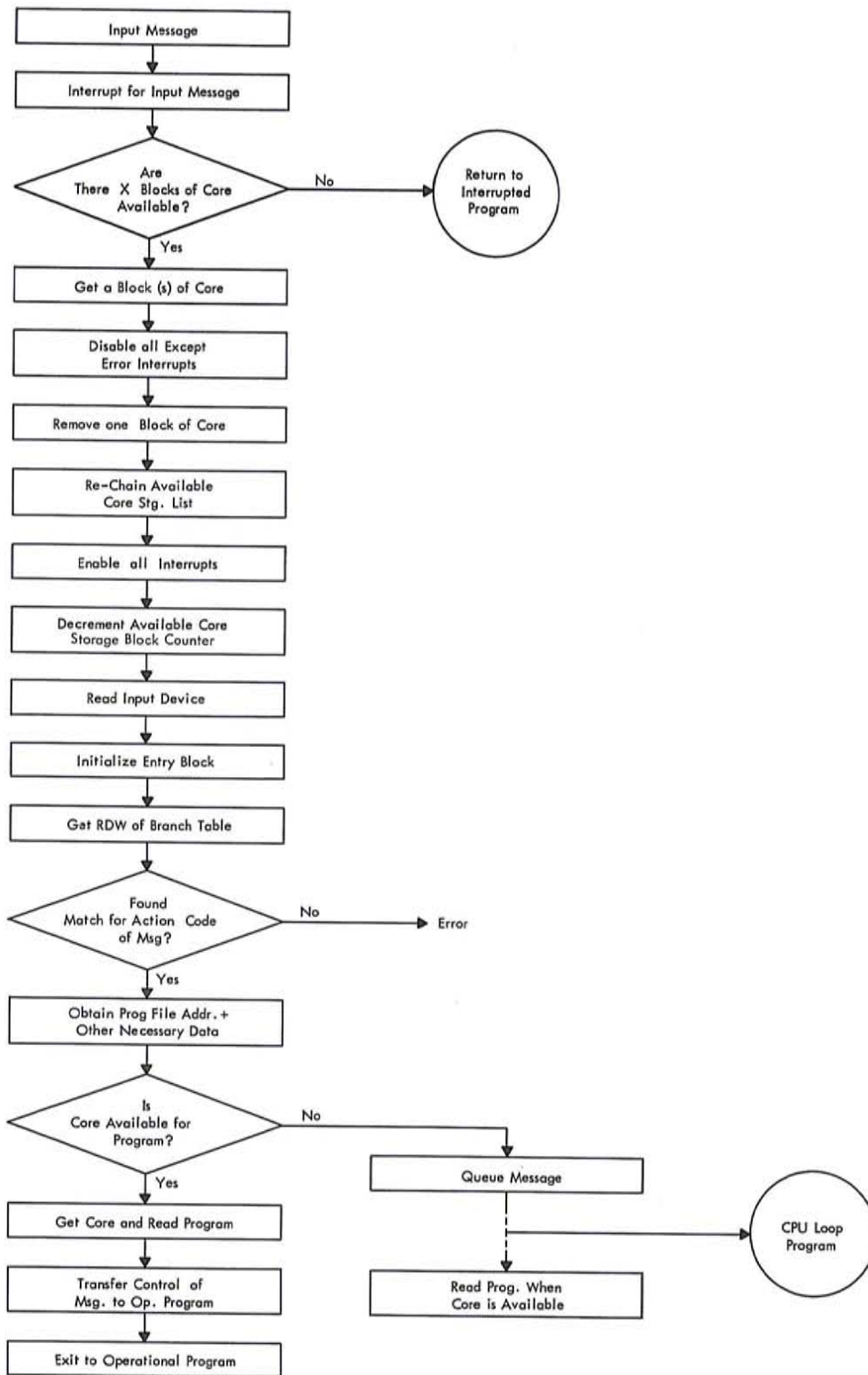
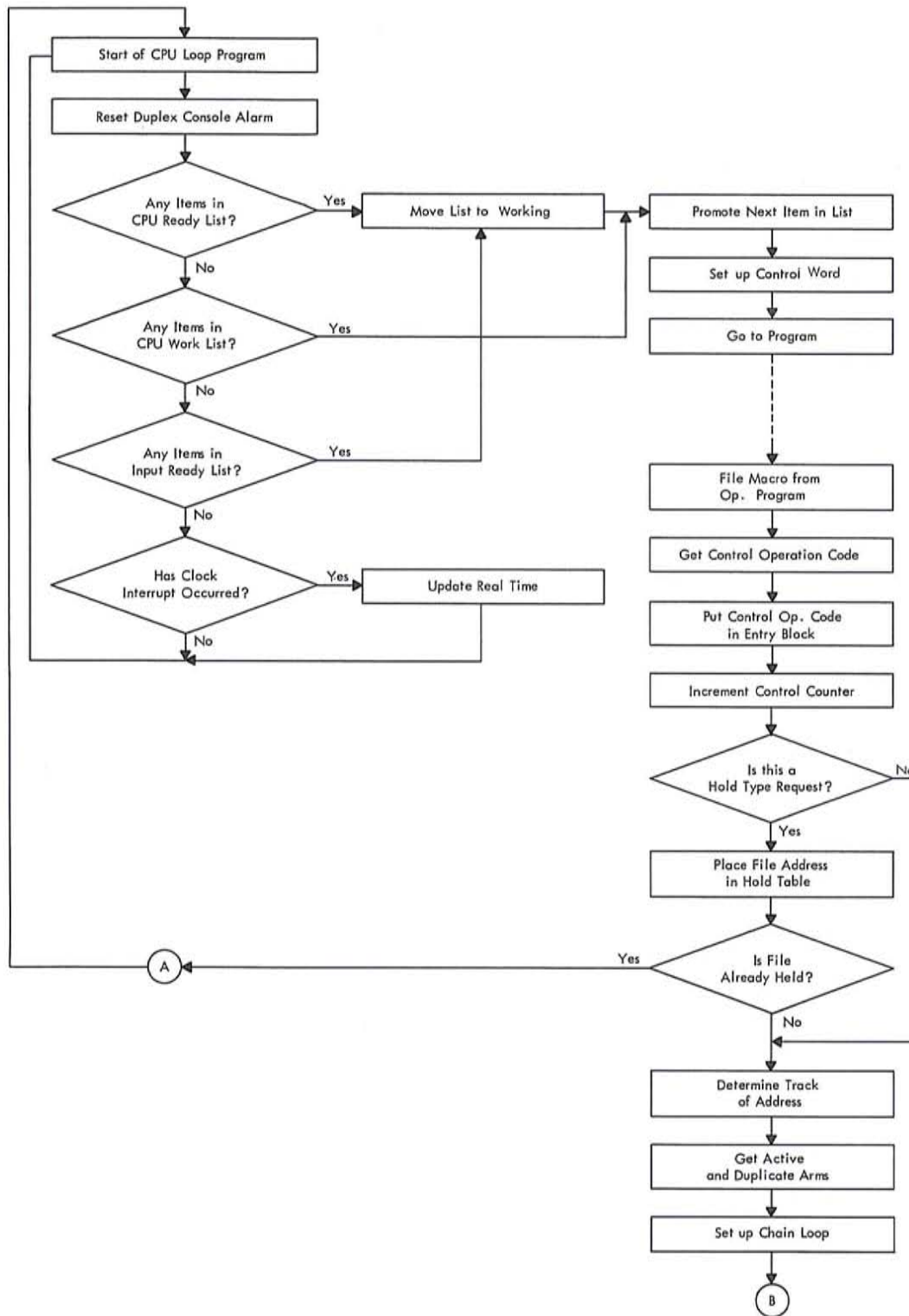

FIGURE 4-11 PROGRAM DESCRIPTION (1)

Southern Pacific Company



CONTINUED ON FOLLOWING PAGE

FIGURE 4-12 PROGRAM DESCRIPTION (2)

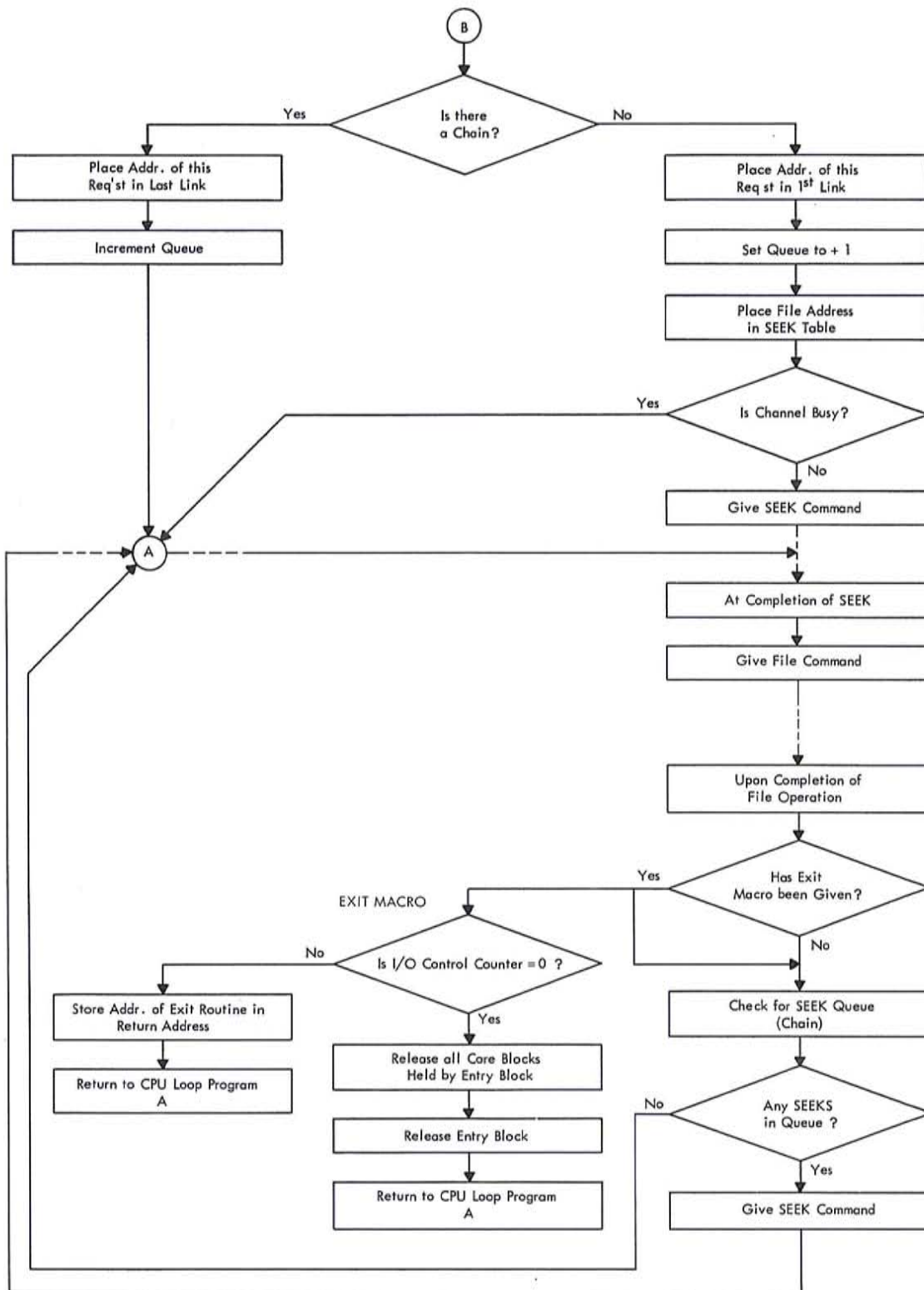

FIGURE 4-12 PROGRAM DESCRIPTION (2) - CONTINUED

The list of available core storage must be updated and recharged as a result of releasing the core storage blocks.

The application program notifies the supervisory program at the completion of processing by giving the EXIT macro (Figure 4-12). This is a signal to the supervisory program that signifies when all input-output requests are fulfilled, and the message processing is completed. The supervisory program must then release all core storage blocks held by this message entry.

The supervisory program must have many other routines to take care of exceptional cases and error procedures. It is estimated that the supervisory program will consist of approximately 5,000 instructions.

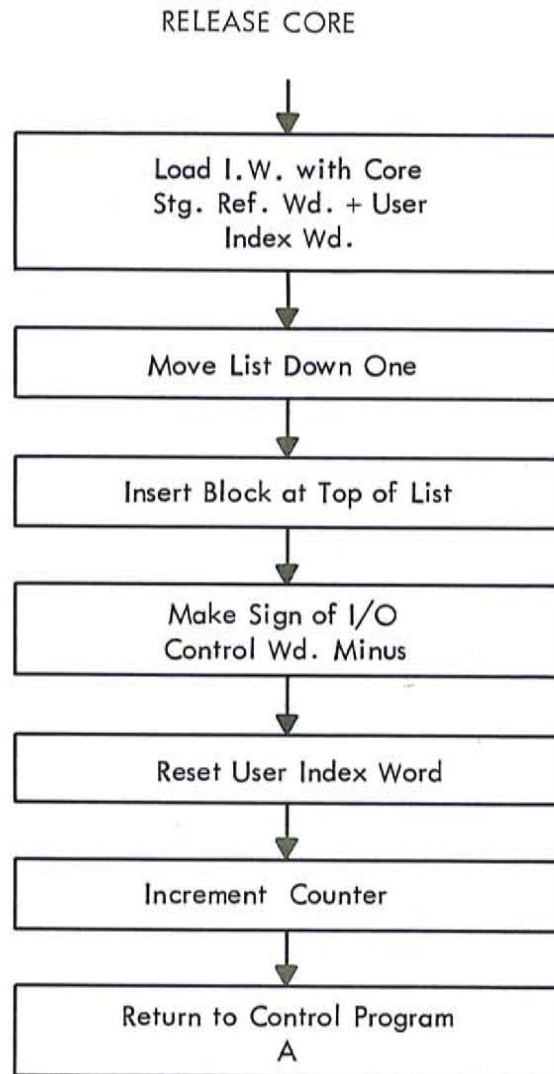

FIGURE 4-13 PROGRAM DESCRIPTION (3)

DIAGNOSTIC PROGRAMS

The availability of a system such as the TOPS System is of paramount concern and every effort is made to utilize the logic of the equipment to ensure maximum availability. One of the outstanding characteristics of the stored program central processor is its ability to diagnose itself and to tell an operator where a malfunction is occurring.

In conventional data processing, diagnostic programs are one of the tools that the Customer Engineer uses to service the processor. However, the high performance that is required of the TOPS System dictates that diagnostic programs be instantly available to locate malfunctions. These programs will be accessible by the supervisory program either on a scheduled basis or when required by a malfunction. In the former case, the programs will be used during periods of low activity in an attempt to locate marginal conditions before an error occurs. In the latter case the appropriate diagnostic will be called by the supervisory program immediately.

The diagnostics will be used in the following manner. If a malfunction occurs, the diagnostic program will be called and used to detect which, if any, of a large number of logical units is causing the malfunction. If a malfunction is detected, the logical unit will be identified to an operator in order that he may evaluate the situation. If the nature of the malfunction is such that a switch-over to the standby processor is not necessary, the logical unit will be removed from the active status for servicing. If, on the other hand, the malfunction is of a critical nature, the standby processor will assume the active role. The formerly active processor will continue to use diagnostic methods to better define the malfunction.

PROGRAMS FOR THE STANDBY CENTRAL PROCESSOR

The Standby Program consists of programs which operate in the non-active processor of a duplex system. The programs are designed to operate under the control of a supervisory routine. Under the control of this routine, the Standby Processor can be instructed to initiate fallback procedures, switch-over procedures, test procedures, statistic gathering procedures, or to run a conventional batch processing program.

If a particular disk module should fail, the supervisory program in the active processor will begin using the duplicate file as the active file and a tape unit as the copy file. The tape will contain all the information required to update the malfunctioning file after it is repaired. The Standby Processor, upon completion of repairs to the malfunctioning file, will use the tape unit to update the file after it becomes active. This allows the active central processor to efficiently perform its function while the Standby Processor handles any back-up file maintenance.

The standby supervisory program, upon an internal signal from the active computer or external signal from an operator, prepares the Standby Processor to assume the active role when scheduled or unscheduled switch-overs occur. This involves the storage and creation of restart procedures for any batch type programs that are in process in the Standby Processor. Upon completion of this function, the standby supervisory program will call the active supervisory program into the Standby Processor.

Just prior to switch-over, the supervisory routine will call in the diagnostic program for testing the entire Standby Processor. These programs are used to assure that a reliable system will be available when the switch-over is performed. They sequence automatically with no operator intervention and may be called upon at pre-determined times, or under specific direction by an operator.

The statistic gathering programs are designed to monitor overall performance. They collect data on the dynamic performance of the TOPS System on magnetic tape. Data reduction programs will present the data in tabular and graphic form for interpretation. The programs are designed to present information pertaining to line performance and loading, as well as system performance in terms of response times, message lengths, line utilization, etc. Through the use of these programs, a current measure of actual performance is made available.

The Standby Programs are designed to operate with a minimum of time and consistent with the required performance of the TOPS System. Their affect on the batch data processing programs on the IBM 7074 should be negligible.

RANDOM ACCESS FILE ORGANIZATION

Primary factors considered in determining file organization and formats are:

1. Satisfaction of the procedures.
2. Ease of programming.
3. Availability of all information required on output messages.
4. Minimization of the number of access motions per day.
5. Minimization of total file storage required.
6. Minimization of core storage required.

The File Organization and Cross Referencing chart (Figure 4-14) is an illustration of the organization of the files. Other items, such as tables and programs, will also be stored in IBM 1301 Disk Files. This organization is conceptual and quite independent of physical position on the disks. Although procedures are written as three separate sets (Freight Traffic, Accounting, and Operating) this division is not adhered to in file organization. Most files are shared, and there is considerable inter-relationship between files. This is evidenced by the dotted lines in Figure 4-14 which show the file linkage; the arrows indicate the direction of the cross-reference. The solid lines represent an input message if the arrow enters the box, and an output message if the arrow leaves the box. Listed below are the files used for the TOPS System.

1. Waybill File
2. Waybill Overflow and Additions
3. Special Account Car File
4. Demurrage and Car Order File
5. Car File
6. Off-line Car File
7. Locomotive File
8. Crew File

9. Crew File Extension Area
10. Train File, Transfer File
11. Train File Extension Area
12. Service Request File
13. Table-Pre-punched Numbers
14. Switcher File
15. Industry Zone Responsibility File
16. Interchange File
17. Yard Responsibility File
18. Repetitive Car Order Table
19. Patron File
20. Abbreviated Equipment Register

The car file, waybill file and demurrage file contain most of the information concerning a car and its load; a reference to the car file moves from one responsibility file to another as the car moves. The responsibility files contain these references plus summary information which measures the performance of that responsibility area, whether it is a train or a location. Other files perform more specific functions which are described on the following pages.

There are two parts to each format in the file. The basic portion is that which contains the information required to satisfy the procedures for which the file was established. The other is the information added to allow sufficient control and proper interpretation. Both are subject to further evolution, the former as a result of procedural refinement, and the latter as a result of program refinement.

File Formats

The following paragraphs explain each file format, and emphasize the portion provided for control and interpretation.

Waybill File

From time of entry to time of output of the freight bill, each waybill is retained in this file. The contents may be abstracted upon request to provide manifest information. An extension address for overflow and additions is provided in order to allow a waybill of greater length than record length to overflow to a shorter record area. One such area is assigned to each waybill on a track, and 40 spaces are available on each cylinder for additional overflow. The assigned overflow area is also used for entry of rates and simple revisions by the central bureau.

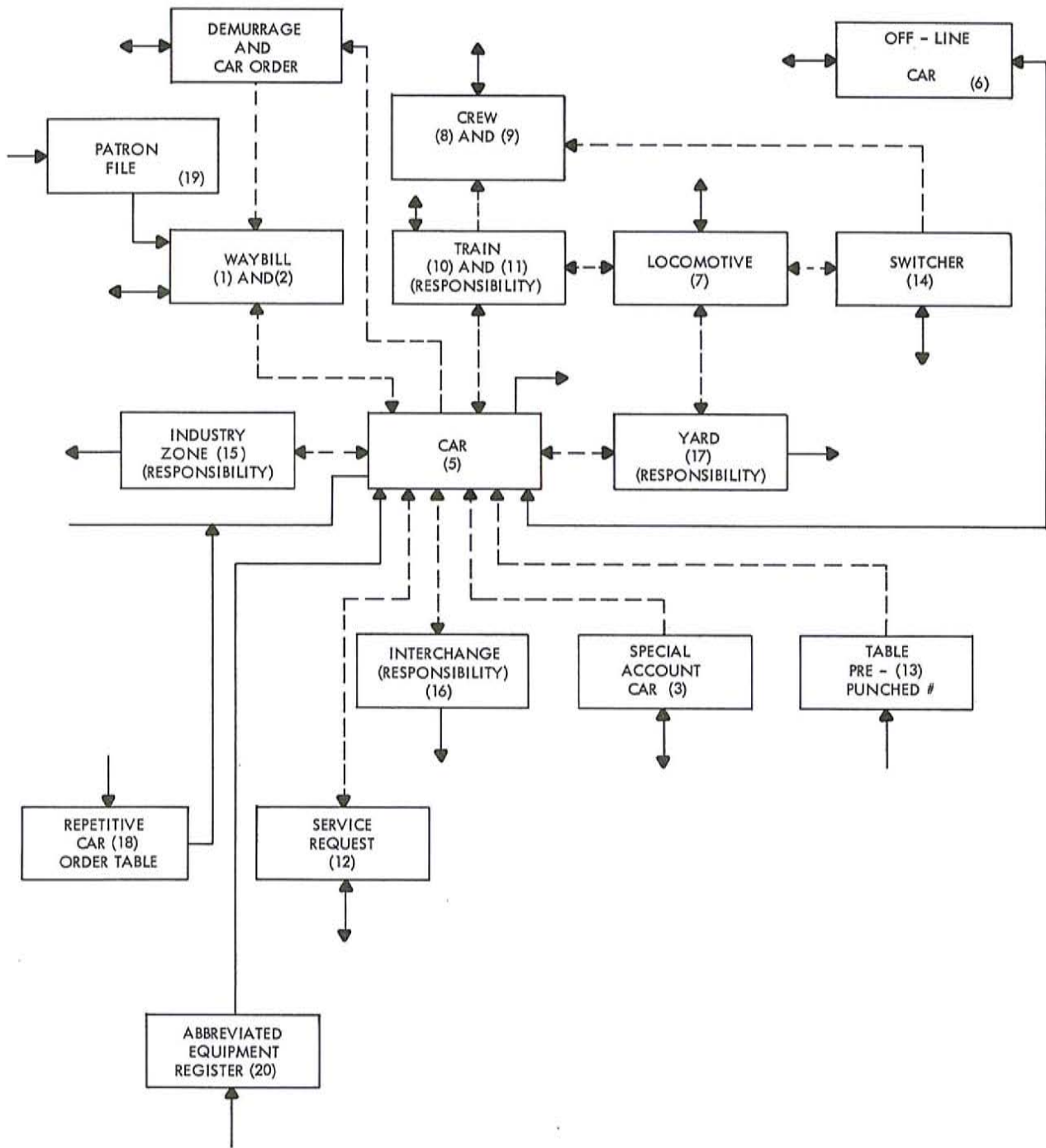

FIGURE 4-14 FILE ORGANIZATION AND CROSS-REFERENCING FOR THE TOPS SYSTEM

Special Account Car File

Each special account patron will have an entry in this file. It simply lists addresses of car file records for each car the patron has on line. Daily tracing output will occur on the basis of these lists. An indicator in the file defines whether a particular record is a first record or an extension record. Extension records will not contain the patron code, name, and traffic office, and will thus allow storage of more cars.

Demurrage and Car Order File

These two files are combined because of a large amount of common data. The file is used to store car orders and demurrage records until the demurrage bill is prepared. The car order portion provides information for car distribution. An indicator defines the status of record as empty, order only, filled order, order and demurrage.

Car File

This file is the heart of the file organization. It serves the following functions:

1. Can be used as an index to all responsibility files, the service request file, waybill file and demurrage file.
2. Contains information from the equipment register on physical characteristics for every car on line.
3. Contains tracing information for every car on line.
4. Contains the operating record for every car on line.

A record is established for all interchange received cars and is made available for every car delivered at interchange. All cards in the PICL or ISC files contain a reference to this file in their address field.

Off-Line Car File (Special Tracing File)

This is a minor league car file for cars which have been delivered at interchange within the past week, and for cars expected on line for which foreign roads have provided prior tracing information. Only the function of providing tracing information is satisfied by this file. The record length per car is one-fifth that in the Car File.

Locomotive File

This file retains a record of the current and previous four locations, for each road or switching locomotive. It also contains the weight and power and a limited amount of maintenance information. Locomotives are handled in a manner similar to cars in switching responsibility from yard to train, etc. One area of potential expansion involves this file. It may be desirable at a future date, to retain complete maintenance records for each locomotive and automatically trigger an output to the proper individuals when maintenance is required.

Crew File

It is intended that crew calling and payroll preparation will remain essentially as they are at present. This file is used as a means of retaining current information, and as a source of data for a check on both of the operations mentioned above. The record length is established for six tricks in a week. If an employee works more than six tricks, the additional information is stored in a Crew File Extension area which is accessed by the extension address field. This area may be further extended if necessary.

Train File, Transfer File

From origination to termination of a train, this file contains complete current and past information on schedule, crews, locomotives, cars and blocks of cars. With the exception of schedule and block consist, this information is stored in the form of a reference address to the appropriate file record.

Service Request File

Service requests and special instructions are stored in this file. When a car changes responsibility, its record in the car file is updated. At the time of each such updating, the reference address is checked to determine if a service request is stored in the service request file. If so, the proper record is accessed and examined to determine whether there is a request for the new responsibility location.

Table of Prepunched Numbers

This file maintains a link between a prepunched number on a pickup-setout card set in the field and the car file address of the proper record. When a car departs before being setout from the last major yard that has an I/O unit, the PICL card is reproduced twice to form the original pickup-setout card set. This original set will contain the direct address to the car file. For subsequent moves, cards are input in mixed pairs; an old pickup card is placed with a new setout card. Thus, the original pickup card is input with a setout card prepared in full. A record is set up in the table of prepunched numbers to relate the prepunched reference number in the setout card (and in the corresponding pickup card associated with the car) to the address of the car file record. Then, the table is changed with each entry; the reference number in the pickup card will always lead the program to the car's address and this address will then be stored in the table opposite the number in the setout card. Two problems necessitate an area for temporarily storing Pickup-Setout card reference numbers:

1. The inputs resulting from various moves may get out of sequence, in which case unrelated prepunched numbers may be input. These must be stored until the table can "catch up" with this number.
2. At remote interchanges there is no way of immediately entering the car initial and number. Therefore, the car file record cannot yet be opened for received cars. Again, temporary storage is needed.

The first three digits of a prepunched number will address the record in the table. Within this record, the last two digits address a position from 00 to 99. The car file address is located in the

proper position. This address will move from one record, or position, to another as new mixed sets of cards are entered.

An area is provided for duplicate numbers. The program must always check this area to assure that it has the proper address. If there is a duplicate, the last four digits of the car number, and the last two digits of the reference number on the setout card which are entered, are checked against the last four digits of a car number and the last two digits of the reference number stored with the duplicate. If they match, the address stored with the duplicate is used.

Switcher File

The switcher file is similar to the train file, but no car file reference addresses are stored. In all other respects it can be considered less detailed than the train file.

Industry Zone Responsibility File

Two purposes are served by this file. It is a responsibility file in which all cars in a zone are stored. The storage method is similar to a train file (reference address plus information from which the car distribution reports may be generated). Each zone has a record, with a sub-division to spurs. The pull flag is established when a car is released. This permits central processor generation of pull lists when a switcher is going out to the zone. Interchange tracks are included in a similar format to indicate interchange responsibility.

Interchange File

This is not the responsibility file, but an area for storage of a day's interchange lists.

Yard Responsibility File

This file contains the same basic information per car as the other responsibility files. It also contains the summary information provided for generation of the turn-over report.

Repetitive Car Order Table

This is a table of repetitive information for car orders which are placed a given number of times per month. Thus, only an address to this file need be entered instead of entering all of the repetitive information. The use count in the table is stepped up by one with each use. It is reduced by a specified number monthly. If this number gets below zero, the appropriate ISC clerk is advised that the order is not being used sufficiently.

Patron File

This file contains the patron code which is furnished by the Rating and Revising Bureau, patron name, billing address, collection agency, and demurrage status. When freight bills are ready for processing, this file will provide the correct statistics for proper handling.

Southern Pacific Company

Abbreviated Equipment Register File

This file contains a condensed table of all cars listed in the Equipment Register, classified as to type only. When cars enter the TOPS System, this file will be accessed so that the correct type of car can be inserted in the operating record.

Tape Records

The information listed below will be stored on tape for use in the TOPS System.

1. Waybill - Copy Record.
2. Waybill- output to Central Rating and Coding Bureau.
3. Messages (selected).
4. Demurrage records.
5. Historical records and purge results.
6. Input for accounting Data Processing Center.
7. Freight bills.
8. Management Supervisory reports.
9. Control Program temporary storage.
10. System Diagnostics.

There will be another tape containing selected information from the equipment register for all freight cars which could appear on line. This tape will be used to obtain the car identification information, such as cubic capacity, weight capacity, etc., on cars received at interchanges.

File Layout

Physical layout must be determined by using access efficiency and reliability as prime factors. The following philosophy of layout provides both efficiency and reliability.

Several assumptions have been made with respect to reliability:

1. Most failures do not destroy records but make them inaccessible for a period of time.
2. No degradation of service is tolerable in the operating and traffic areas.
3. Inaccessibility of a small portion of the waybill file is tolerable for periods of a few hours. This is based upon the long cycle time for billing.

To minimize access time and distribute utilization equally among all modules, it is necessary to distribute each file among all modules. A copy record will be

maintained in separate units for each portion of each file, except the waybill file.

When a failure occurs, any address generated to an inoperative unit is modified to address the copy record. For waybills, the message is stored on tape until the unit becomes operative.

Whenever an original is written, its copy must also be written.

Placement of the file portions on each module can be relatively determined by examining the cross referencing scheme illustrated previously in Figure 4-14. For example, the car file and the responsibility files should be close together. When conflict occurs, priority should be given to the most frequently used files.

EXAMPLE OF A TRAFFIC PROGRAM-TRACING REQUEST

A Tracing Request enters the TOPS System through a Traffic Office I/O unit. When the central processor receives a tracing request, it must locate this car's record and from this record form a reply and send it to the requesting Traffic Office. The central processor's action for performing this task can be seen by studying the block diagram in Figure 4-15. Each numbered block in the diagram will be further explained in the following outline.

Blocks 1 - 4 The program will locate the Line Address Terminal Address (LATA) of the I/O unit and car initials and number in the input message, and transfer these two fields to the output message assembly area. It will then load the input car initials and number into the working area of the central processor (accumulator) where it can perform an editing operation on the car initials and number to get this data in the form needed to generate the Car File Address. The editing operation mentioned above does a character-by-character search of the car initials to the left of one central processor storage word and the car number to the right of another storage word (See Figure 4-16). The car initials and number are then stored in core to be used later in the program. The next step in the edit operation is to strip the zone bits from the car initials and number, and combine them into one word (See Figure 4-16).

| | | |
|-------------------------------------|--------------|----------------------|
| Example Input: | clerk types: | SP 123456 |
| enters computer in alphameric mode: | | 8277009192 934959600 |
| 1. | 8277000091 | 9293949596 |
| 2. | | 2700123456 |

FIGURE 4-16

The edited car initial and number is now ready to be used by the random address generation routine. This generating scheme takes the edited word and divides it by a prime number, which is approximately equal to the file size, to produce a 4-digit remainder. A program constant is added to this remainder to create a track file address.

Southern Pacific Company

TRACING REQUEST

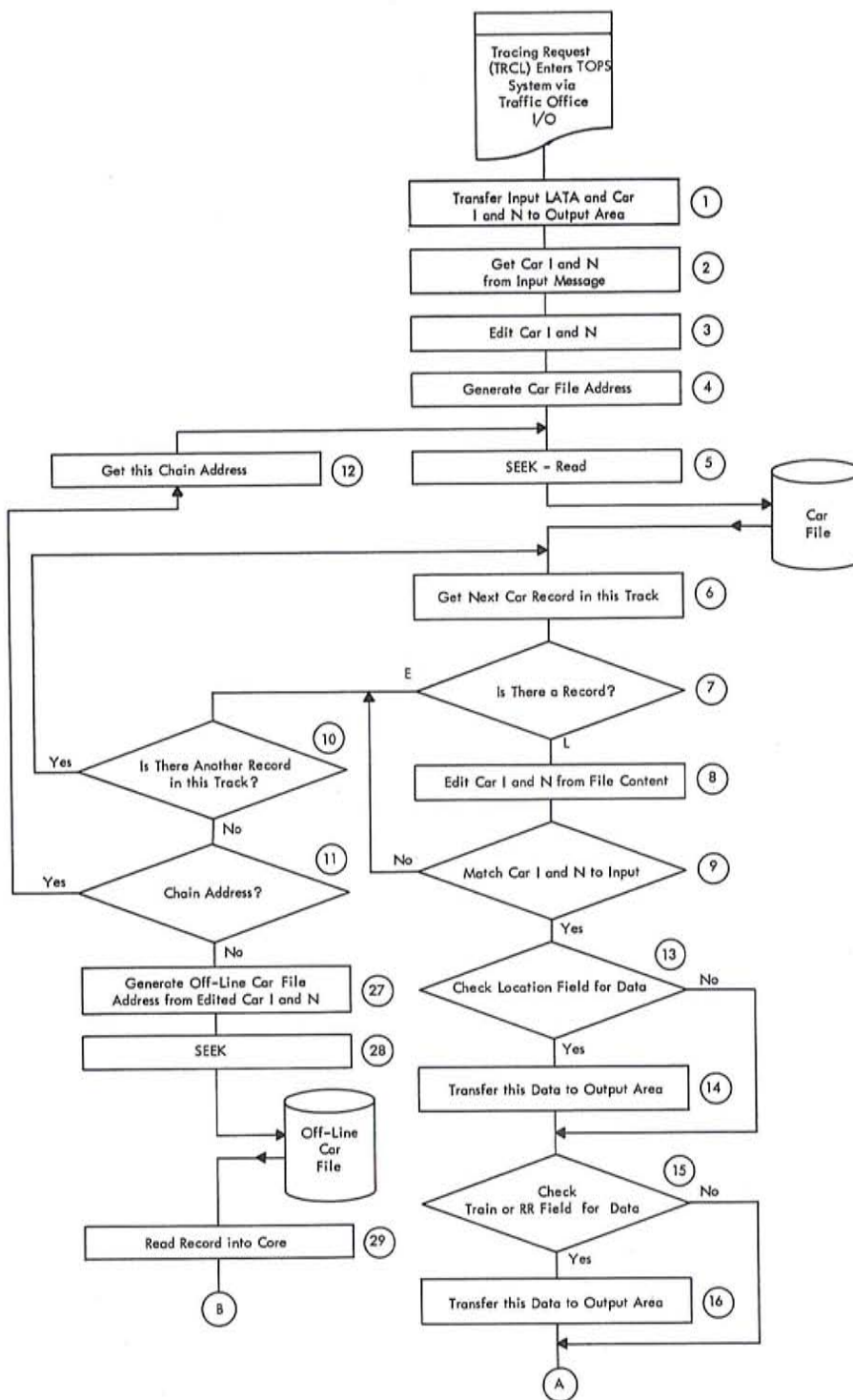

CONTINUED ON FOLLOWING PAGE

FIGURE 4-15 PROGRAM EXAMPLE - TRACING REQUEST

TRACING REQUEST (CONTINUED)

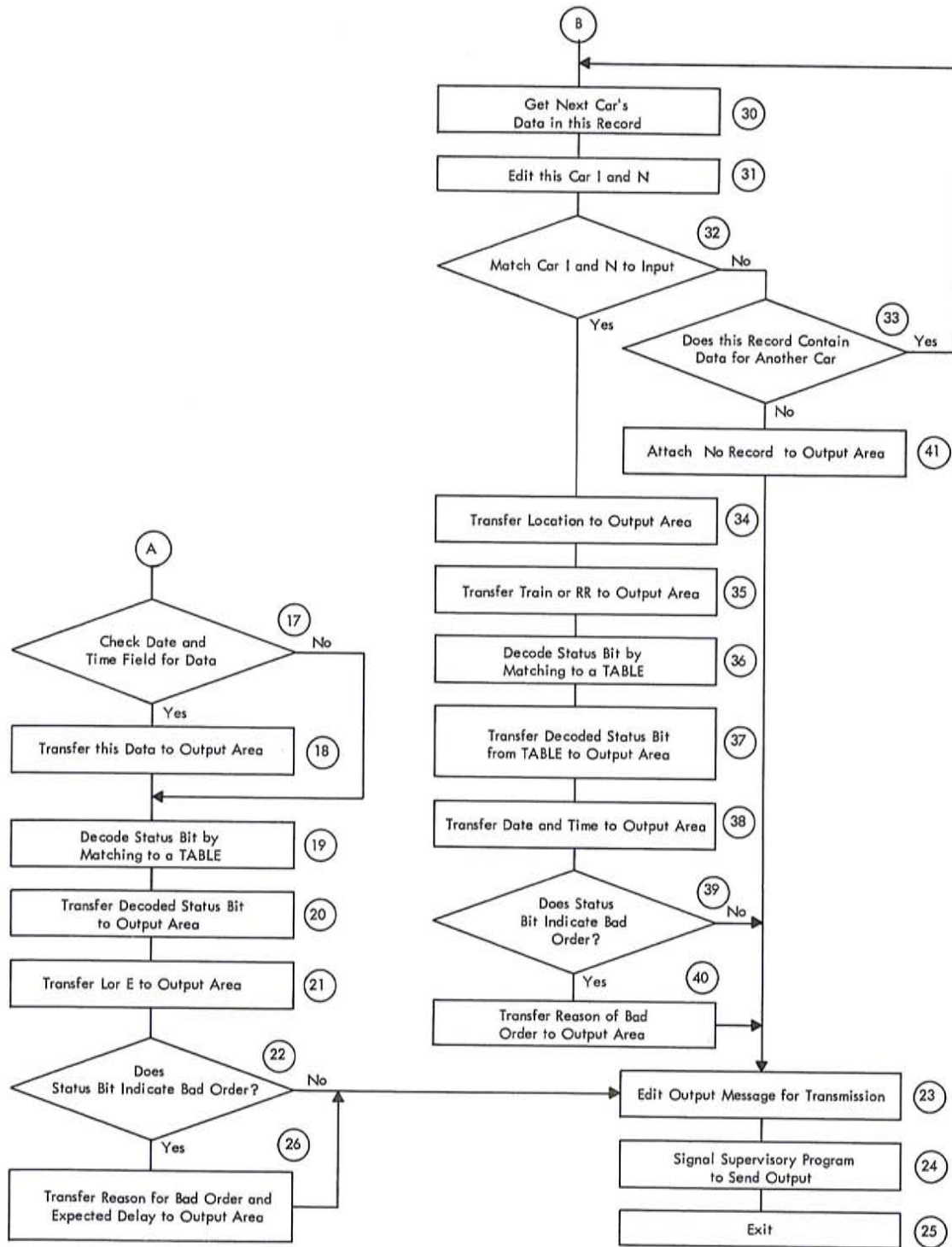

FIGURE 4-15 (CONTINUED)

Blocks 5-12 This group of blocks constitutes the internal operations of this generating routine. The track file address created in the manner described above is located in its designated disk file and the entire track is read into core. One track is capable of holding 14 car file records. Since each car record is a fixed format, the indexing feature of the IBM 7074 enables the programmer to select any specific field in a record and any specific record in the track. All 14 of these records have the same chain address for overflows; this chain address is stored at the end of the track. The first record in this track is located by indexing. The car initial and number stored in this record is then selected (again by indexing) and loaded into the accumulators where it can be shifted character by character until it is in the form shown in (1.) of Figure 4-16. The car initial and number from the file content is compared to the edited input car initial and number that was previously stored by the program. If they match, the program exits from the generating scheme via (A). If they do not match, the next car record in this track is located and the process is repeated. If the entire track is searched in the above manner and no match is found, the chained track is then read into core storage and examined in a like manner. The result of this type of generating scheme, which searches for a specific record is:

1. Locating the desired record (Exit (A)) or
2. Not locating the desired record (Exit (B)).

Blocks 13 - 21 This group of blocks examines the specific fields of the car's file record in search of the data necessary for assembling the output message. Each field is transferred to the working area of the central processor where it is compared to zero; if greater than zero, this field contains data and this data is transferred from the working area to the output message assembly area. If the field is equal to zero, it does not contain data, and therefore it is not added to the output message. Every record in the car file will contain a status character (alphameric) which will represent the descriptive condition of the car. (Examples: B = Bad Order, T = Transit, S = Spot, etc.) Every alphameric character and its associated descriptive condition will be stored in a Status Code Table. This table will be part of the program. In the next step, the program will take the status bit in this car's record and load it into the accumulator. A program constant will be added to it so that it becomes the search argument of a Table-Lookup operation which determines the significance of the status character. Once the lookup is completed, the descriptive portion of the table pertaining to this alphameric character is transferred to the output message assembly area.

Blocks 22-26 This section compares the status bit to a constant that contains the alphameric character signifying a Bad Order. This comparison is performed because if it does indicate a Bad Order, more information is needed to complete the output message. The additional information consists of:

1. Reason for the Bad Order, and
2. The expected delay.

This additional information is found in the car's record and must be located by indexing and transferred to the output message assembly area.

- Blocks 23-25 These blocks edit the output message to the specifications required for transmission, notify the supervisory program that there is a message to send, and defines the Record Definition Word that states the core location of the beginning and end of the output message. The edit operation mentioned above includes the functions of inserting the End of Address character (EOA) after the LATA for control operations in the IBM 7750. In this way, a message can be sent to more than one location if necessary. Carrier return, line indexing and any special characters are inserted at this time, as well as the End of Message character (EOM).
- Block 27 The address generating scheme for the Off-Line Car File is basically the same as that for the Car File. It uses the same word as that in (2.) of Figure 4-16, but divides this word by a different prime number which is considerably smaller than that for the Car File.
- Blocks 28-33 This group of blocks is part of the generating scheme but is shown here to give a detailed picture of the routine. The remainder found after the divide operation is loaded into an accumulator. There, a program constant is added to it; this constant also contains the operations (OP) code with the seek instruction for the disk storage circuit. Once the designated record is located by the disk file head, using more than one seek if required, it is read into core. The Off-Line Car File is capable of holding 5 car records per file record. The indexing feature enables the programmer to locate any one car's data in a record and any specific field in the car's record. It scans the entire record in the same fashion as the car file and:
1. Locates the desired record (Yes path of block 32) or
 2. Does not locate the desired record (No path of block 33).
- Blocks 34-40 These blocks transfer the required data found in the car's record to the output message assembly area. This is accomplished by taking each field, loading it into the accumulator, and then transferring it to the output area. (Similar to the regular Car File)
- Block 41 The program arrived at this block by not finding the car's record in the Car File and Off-Line Car File. There is no record of this car in the TOPS System. Therefore, the program has constants built into it to designate "No Record", and these constants are transferred to the output message assembly area.

EXAMPLE OF AN ACCOUNTING PROGRAM - WAYBILL HANDLING

Complete waybill data will be entered into the TOPS System through Waybilling and Transmission Sets. This data is developed into compact records and stored in the disk files. At an appropriate time, the waybill data will be sent to the Central Rating and Revising Bureau for changes, coding and rate revision. Corrections and additions will be entered into the TOPS System and the waybill file record will be reviewed, revised and returned to the files for storage. If a freight bill is required, it will also be prepared at this time and sent to the regional center which handles the freight billing for this patron. Finally, when the car leaves the home road or the car is delivered and unloaded, the waybill record will be removed from the active disk file and stored as an inactive record on a magnetic tape for historic purposes.

The waybill is prepared on a Waybilling and Transmission Set. The input message which is transmitted after the waybill has been typed contains a sequence of characters; some are data characters, and the remainder are control or operational characters. The control characters are the coded information describing the type of message, the line and I/O unit sending the message, the end of the message (E. O. M.) character, etc. The printer operational characters describe such things as spacing and platen indexing, both forward and reverse. All the possible control and operational characters are specified and described by unique characters; all other legitimate characters are assumed to be data characters and are handled as such. This sequence of characters, obtained as the waybill is typed to make up the input message, is received by the central processor and stored in a selected area of core storage. An example of the input message, the message stored in the processor core, and a section of a sample waybill from which these messages might have been generated can be seen in Figures 4-17, 4-18, and 4-19. The lower case letters represent the printer operational characters. In this example, "s" represents a space, "c" indicates a carrier return, "t" shows a tab functions and "i" is for platen indexing.

... ssssssss MILWAUKEE, s WISCONSIN tss 6500 ss LOS ANGELES
s CALIFORNIA cii SP s STA s ROSA s CPIP .. ETC

FIGURE 4-17 SAMPLE TRANSMISSION MESSAGE OF WAYBILL

| | | | | | | | | | |
|--------|--------|-----------|---------|--------|--------|--------|---------|---------|--------|
| sssss | ssss M | ILWAW | KEE, | WISCO | NSIN t | ss 650 | 0 ss LO | S.s ANG | ELES s |
| s CALI | FORNI | A c i i S | P s STA | s ROSA | s CLIP | ETC | | | |
| | | | | | | | | | |
| | | | | | | | | | |

FIGURE 4-18 SAMPLE OF INPUT MESSAGE IN CORE STORAGE

| | | | | | | |
|----|---|----------------------|---------------|---|-------------------------|---------------|
| | AT | | | | | |
| | TO NO | STATION | STATE OR PROV | FROM NO | STATION | STATE OR PROV |
| 20 | () | MILWAUKEE, WISCONSIN | | (6500) | LOS ANGELES, CALIFORNIA | |
| 21 | ROUTE (SHOW EACH JUNCTION AND CARRIER IN ROUTE - ETC) | | ROUTE CODE NO | FULL NAME OF SHIPPER AND FOR C. O. D. SHIPMENTS STREET, POST OFFICE ADDRESS, AND INVOICE NUMBER | | CODE NO |
| 22 | SP STA ROSA CRIP STIP | | SRAJ | PABST BREWING CO. SNO LA 58004 | | |
| 23 | | | | LOS ANGELES, CALIF BL SGD 1 30PM | | |
| 24 | SHOW A IF AGENTS ROUTING OR S IF SHIPPING | | | OCT 26, 1960 | | |
| 25 | RECONSIGNED TO | | | ORIGIN AND DATE, ORIGINAL CAR - ETC | | |
| 26 | | | STATE OR PROV | | | |

FIGURE 4-19 SAMPLE SECTION OF A WAYBILL (AAR 98)

Three routines are available for Waybill handling:

Routine # 1 - Waybill Entry Processing

Figure 4-20 illustrates this routine. The processor takes the characters from the input message in a sequence and uses each character, in turn, as the argument in a table look-up equal operation. The table contains all the printer operation and message control characters and, if a look-up is unsuccessful, the character is assumed to be a data character. This data character is stored in a specified location in core storage to develop the Waybill Image. As each data character is stored, index words used as counters are incremented to specify the next location in which a data character is to be stored. Two more index words are used to keep track of the character position within a word and the storage word core location. A control word is also maintained to keep track of the largest core address in the Waybill Image area. If the look-up equal is successful, the address of the next instruction is also listed in the table word so that the program can branch to a routine that will perform the necessary processing. For example, the space character will simply increment the storage index counter so that a blank space will be left in the core. Similarly, the carrier return, platen indexing, etc. will adjust the index counters to reflect the proper character position and word location in which to store the next data character. As each character is pulled from the input message, two other index words will be similarly incremented to keep track of the next character to be pulled from the input message. Finally, at the end of the input message, the E.O.M. character will be pulled and identified; this will signify exit from this routine in the block diagram.

The storage area now contains a Waybill Image in the core; an example of a section of this core can be seen in Figure 4-21.

The next step in the processing, as shown by blocks numbered 8 through 19 of Routine # 1, reduces the Waybill Image to a compact record for the files. First, a logic check is made on a specified field in the Waybill Image which will contain information to determine whether the record is valid. If gross errors made during waybill preparation invalidate this waybill record, the waybiling clerk will enter a code in this specified field. If such a record is found, processing is halted and the program exits. If the processor determines that the Waybill Record is valid, it will select words from the Waybill Image, one at a time, and determine whether the words contain any data characters.

| | | | | | | | | | | | | | | | | | | |
|----|----|---|-------|------|-------|------|------|--|-----|-------|------|--------|----------|-------|-------|----|-------|-------|
| | | M | ILWAU | KEE, | WISCO | NSIN | | | 650 | 0 | LO | S | ANGELES, | CALIF | ORNIA | | | |
| | | | | | | | | | | | | | | | | | | |
| SP | ST | A | ROSA | CRI | P | STP | | | | PABST | BREW | ING | C | O | SNO | LA | 58004 | |
| | | | | | | | SRAJ | | | LOS | A | NGELES | CAL | IF. | B | L | SGD | 130PM |

FIGURE 4-21 IMAGE OF WAYBILL IN PROCESSOR CORE (SECTION FROM SAMPLE WAYBILL)

The processor will store any word containing data characters in the file format area. After each word has been examined for data characters, it is compared to the previous word. If they are the same (i.e. both are data words or both are empty words) an index word, used as a control field counter, is incremented by one. If the words are opposite, the previous counter is stored and a new counter is begun. In this way, a sequence of two-digit counters is developed which alternately counts the series of empty words followed by the number of data words as the Waybill Image is scanned from the first word through the last word. After each word is processed, an indicator is set which describes the type of word just checked as either empty or data. This indicator is used to compare the present and previous word type. In addition, index words are incremented as needed to keep track of the word which is to be examined next in the Waybill Image, the storage location for the next data word which enters the file format area, and the character position and word location of the counters. The first control field counter always contains the number of empty words first encountered and establishes rigid format for control. In the event that a counter exceeds 99 in any given count series, the 99 is stored and followed immediately by a 00 count field; the counter is reset to 00 and the counting continues normally. The control word that lists the last word location in the Waybill Image is incremented and compared to the control word containing the address of the last word in the Waybill Image area. When the comparison is equal it indicates that all the words in the Waybill Image are processed and this causes an exit from the loop. Figure 4-21, shown previously, and Figure 4-22 show examples of a section of the Waybill Image core area and the file format area.

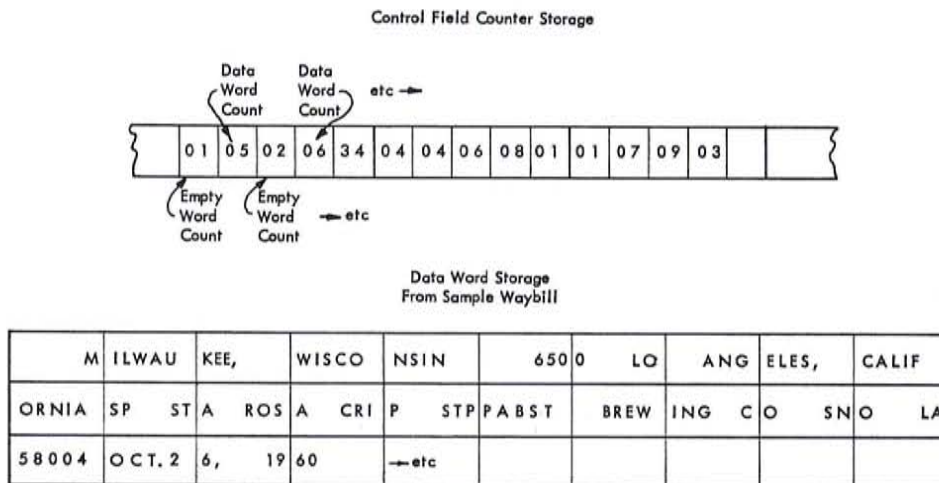
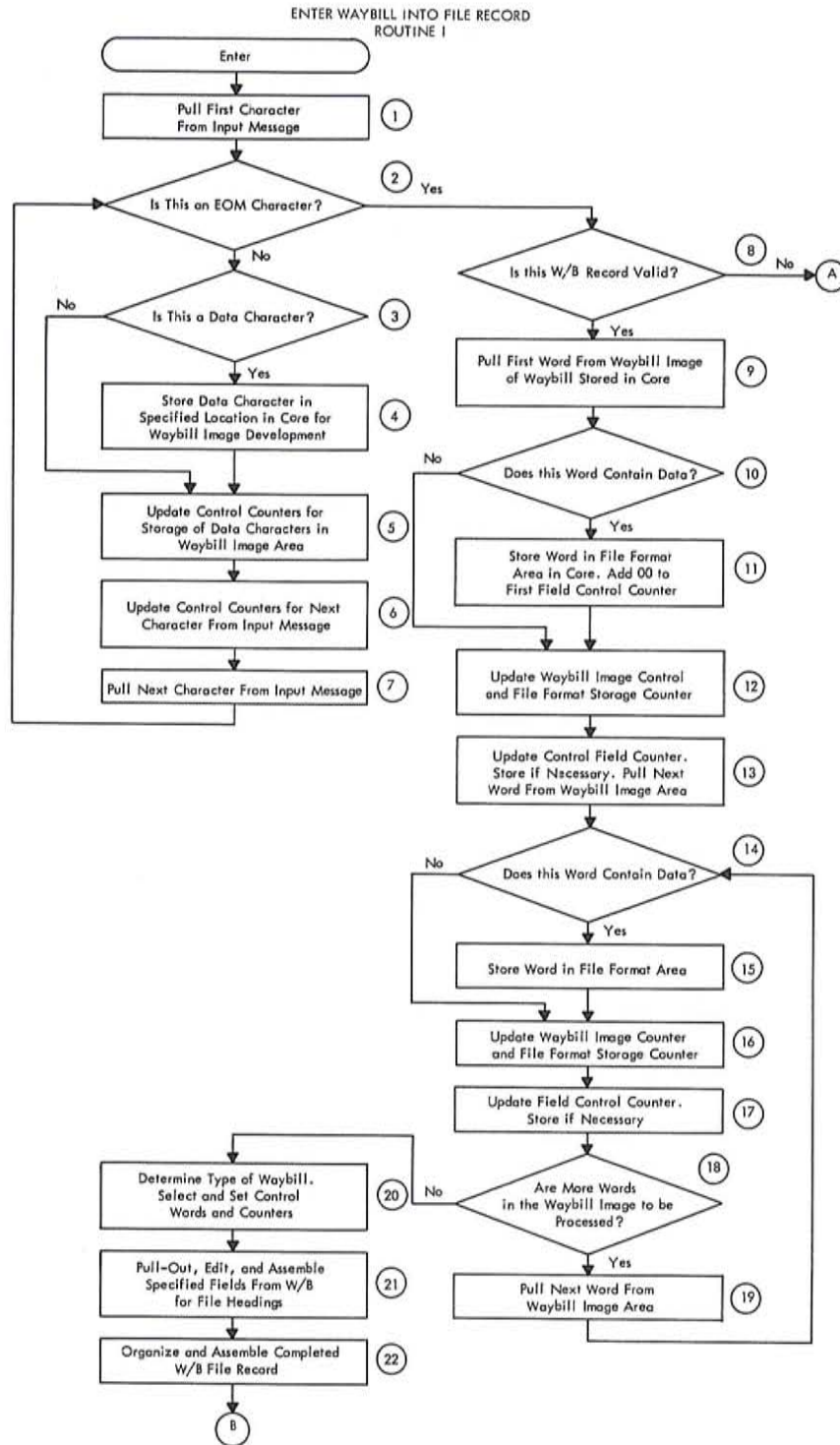

FIGURE 4-22 FILE FORMAT WORK STORAGE AREA IN CORE



CONTINUED ON 2 FOLLOWING PAGES

FIGURE 4-20 PROGRAM DESCRIPTION FOR WAYBILL ENTRY INTO FILE RECORD (ROUTINE #1)

ENTER WAYBILL INTO FILE RECORD (CONTINUED)

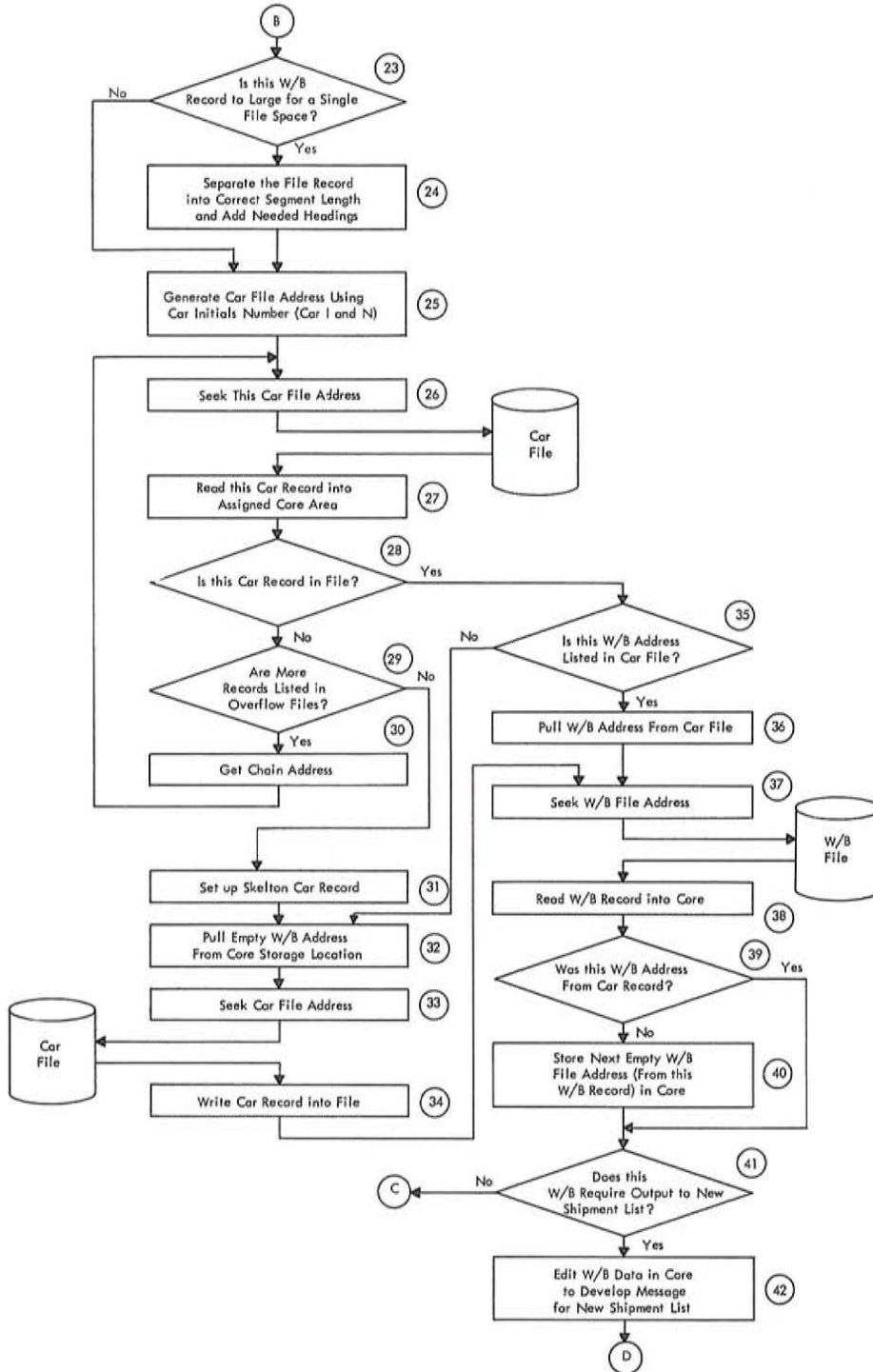

FIGURE 4-20 (CONTINUED)

ENTER WAYBILL INTO FILE RECORD (CONTINUED)

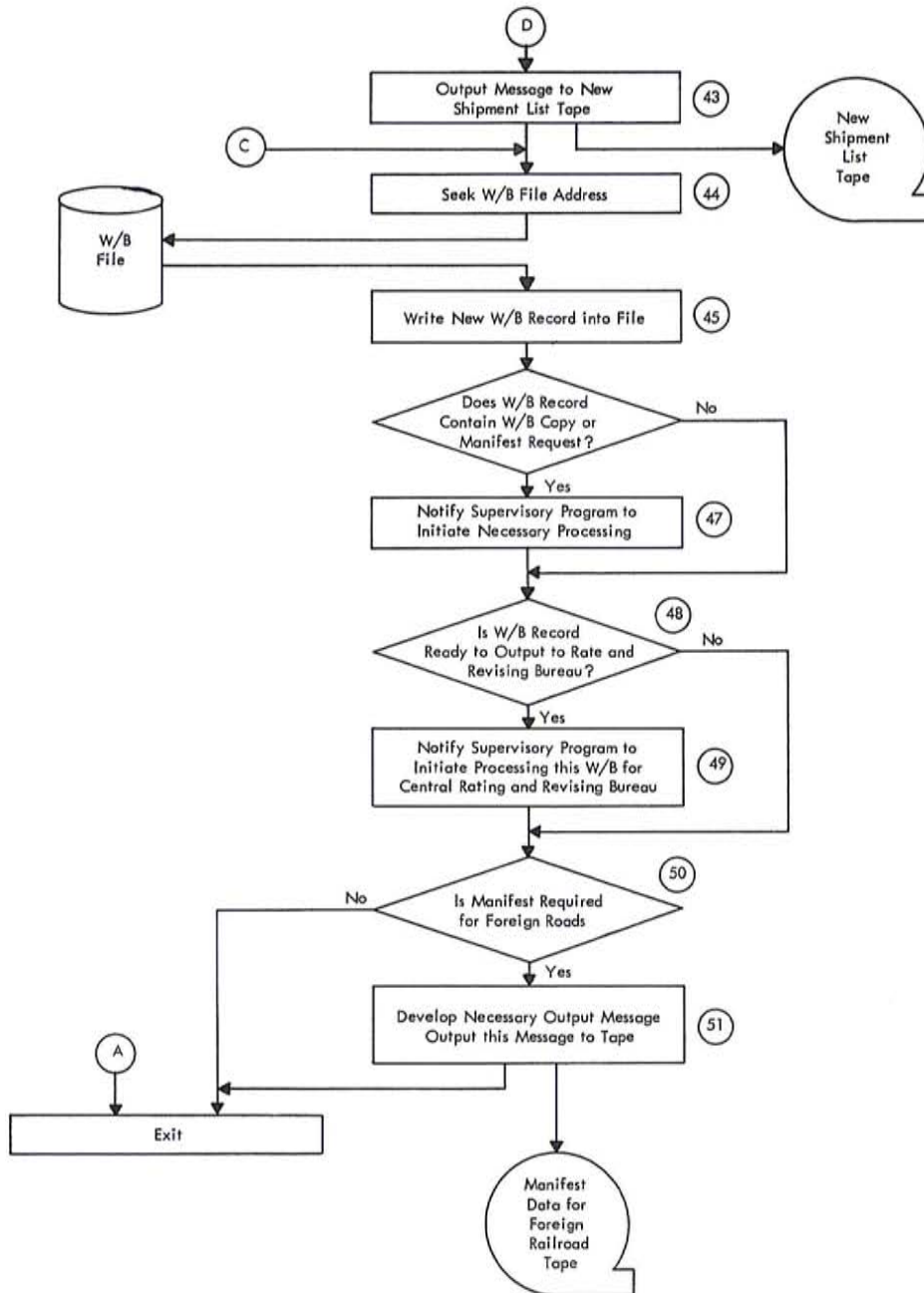

FIGURE 4-20 (CONTINUED)

In order to complete the waybill file record, the necessary file record heading fields must be developed, the record must be joined to a closed series, and the record length must be examined to determine the amount of file space required. This processing is shown in the Figure 4-20, Routine # 1, in the blocks numbered 20 through 24. The type of waybill format will determine a list of Record Definition Words. These words will describe the areas in the Waybill Image in which the fields containing the data needed for the file record headings, such as Car I & N and Waybill Number, will be found. Each of these areas is pulled from the Waybill Image and all the empty words are eliminated, leaving only those records containing data. The control field counters are joined to the data words and form a single record. The Car I & N, Waybill Number and Waybill Type are entered into their proper positions in the file record. The length of the entire record is now determined and compared to 927 characters. If the record is less than 927 characters, it will fit into one record area; if it is greater than 927 characters, the record is divided into one 927 character file record and as many 240-character segments that are required to completely contain the entire record. These 240-character segments are filed in overflow areas which are chained together to keep all portions of a waybill linked.

Using the Car I & N from the waybill, a car file address is generated according to the car file generating scheme previously explained in the Freight Traffic Car Tracing Program. If a car file record is found for this car, it will contain a waybill address for this waybill; therefore, the car file record is accessed and the record is read out of the file. Since each car file track contains 14 car records, each one must be checked for Car I & N. If no record of this car is found in this track, it must be determined whether any overflow tracks might contain this car record; if such an overflow area is indicated, this area is similarly checked for the car record. In the event that no car record is found for this car, the next empty waybill address, which is stored in a specified core location, is pulled out. The waybill record at this address is accessed and is read into core. If this car had no car file record, a skeleton car file record is established listing Car I & N and Waybill File Address, etc. This record is then written back into the car file. The car file address, in either instance, is then added to the Waybill File Record. The waybill file is then accessed and this waybill record is written into the files. If the car file record was not found, the next empty waybill file address contained in the waybill record is read from the files and stored in the processor core. This address is used to store a subsequent waybill in the files. An example of the waybill file record is shown as Figure 4-23, and the depiction of this phase of the processing is shown by block numbers 25 through 40 and 44 and 45 in Figure 4-20, Routine # 1. The remaining processing checks certain fields in the waybill file records, the Waybill Image itself, and the car file records to determine whether certain output messages and processing should take place at this time, be deferred, or should not be performed at all. If this waybill passes certain criteria, such as not containing characters in a field indicating "do not manifest", etc., this waybill is edited so that certain fields will be output to tape for a new shipment's list.

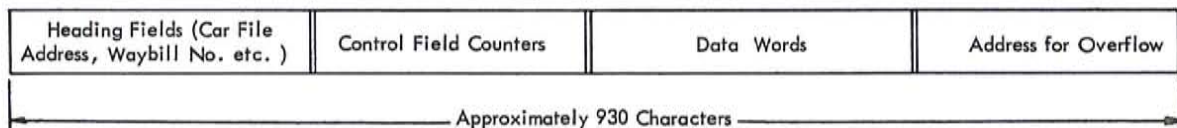

FIGURE 4-23 COMPLETED W/B FILE RECORD FORMAT

The fields, such as the state from, state to, shipper's name, consignee's name, etc., will be condensed, assembled, and output on tape for this purpose. Figure 4-24 shows the proposed format of this record.

| | | |
|------------|--|------------------|
| State from | Station Originated at or on - Coming Junction | Shipper's Name |
| State to | Station to or off-Going Junction | Consignee's Name |

FIGURE 4-24 FORMAT FOR NEW SHIPMENTS LIST

If a waybill record had been established for this waybill, one of the fields may contain characters that will indicate that either a waybill copy or a manifest report has been requested to be sent to some line and I/O unit. In this event, a message defining the routine which performs this processing will be given to the supervisory program. The supervisory program will select and input this program, and the entrance and exit will be adjusted so that this program will start and, when finished, return to the next instruction in the waybill program to continue processing. Upon completion of this request program, the next processing procedure checks the Waybill Image and determines if it is ready for the Rating and Revising Bureau. If so, a special message is given to the supervisory program, and the application program that is to perform this processing is selected and entered into the processor in the same manner as previously described. After the new routine has been completed, control will be returned to the waybill program. The final step in the processing procedure is to pull the route field from the Waybill Image. A comparison of the routing is performed to determine whether this car is destined for certain railroads for which S. P. provides manifest and passing reports. When a message is required, it is assembled and written on a tape unit for this type of data. The program then notifies the supervisory program that this routine has ended and the core is available for other programs.

Routine # 2 - Output Waybill to Tape for Central Rating and Revising

This program illustrated in Figure 4-25, is initiated either when the waybill is first entered into the processor and found to contain all the information required for freight billing, or at a later date when this information is received by the TOPS System. The Waybill Image will be in core storage if this processing is initiated upon waybill entry. In the other situation, the waybill file will be accessed on entry of the data, and the Waybill Image will be created. In updating the waybill, a check will be made to ensure that the correct record has been located.

If the Waybill Image is not already in core storage, it is developed by examining the control field counters and the actual data words of the waybill. The first counter determines the number of empty words to be left at the beginning of the Waybill Image. This is accomplished by incrementing an index word that is used as a storage word indicator. A pair of index words are also used to keep track of the next field counter to be pulled; one locates the next control field counter character location within a word; and the other contains the core word location. The second field counter determines the number of data words to be stored in the Waybill Image area. The specified number of data words are pulled from the waybill file record in sequence and stored in the Waybill Image. Again, the index words are properly incremented to keep track of the storage locations. The field counter that follows specifies the next sequence of empty words for the Waybill Image, and is processed as before. Each succeeding field counter alternately specifies the number of data words to be stored in the Waybill Image area, and is followed by the number of empty words to be left in this area. This procedure continues until all the control field counters and data words have been processed. At the completion of this loop, an image of the waybill that was prepared in the field is in core storage. This loop is shown as block # 8 of Figure 4-25, Routine # 2.

After determining the type of waybill, control words and counters are set so that certain fields of the waybill (e. g. station to, station from, patron codes, route code, commodity code) may be pulled out. This procedure is followed so that these fields may be relisted at the bottom of the waybill record to emphasize which codes are missing or improperly positioned within the specified field. The information is thus brought to the attention of the rating and revising clerks. The waybill file address and the type of waybill and traffic are pulled from the waybill record and listed as a heading for this message. The entire message, including the headings, Waybill Image, specified fields for codes, and any additions that were placed on the end of the waybill file record are read out onto the tape for the Rating and Revising Bureau. The vacancy character of the waybill record is set to indicate that this record has now been output to the Central Rating and Revising Bureau. The waybill file address is then accessed and this waybill record is written back into the files. The program then exits, and notifies the supervisory program that the processing is complete and that the core space is available for other processing.

Routine # 3 - Waybill Revision and Freight Bill Output

This program, illustrated in Figure 4-26, is initiated when the Central Rating and Revising Bureau inputs additions and corrections for a waybill. The waybill file address is included in the input so the waybill file can be directly accessed, and the waybill record can be read into the processor core. From this record, the Waybill Image is developed in core storage, as described in Routine # 2. Each correction or

OUTPUT WAYBILL TO TAPE FOR CENTRAL RATING AND CODING
ROUTINE 2

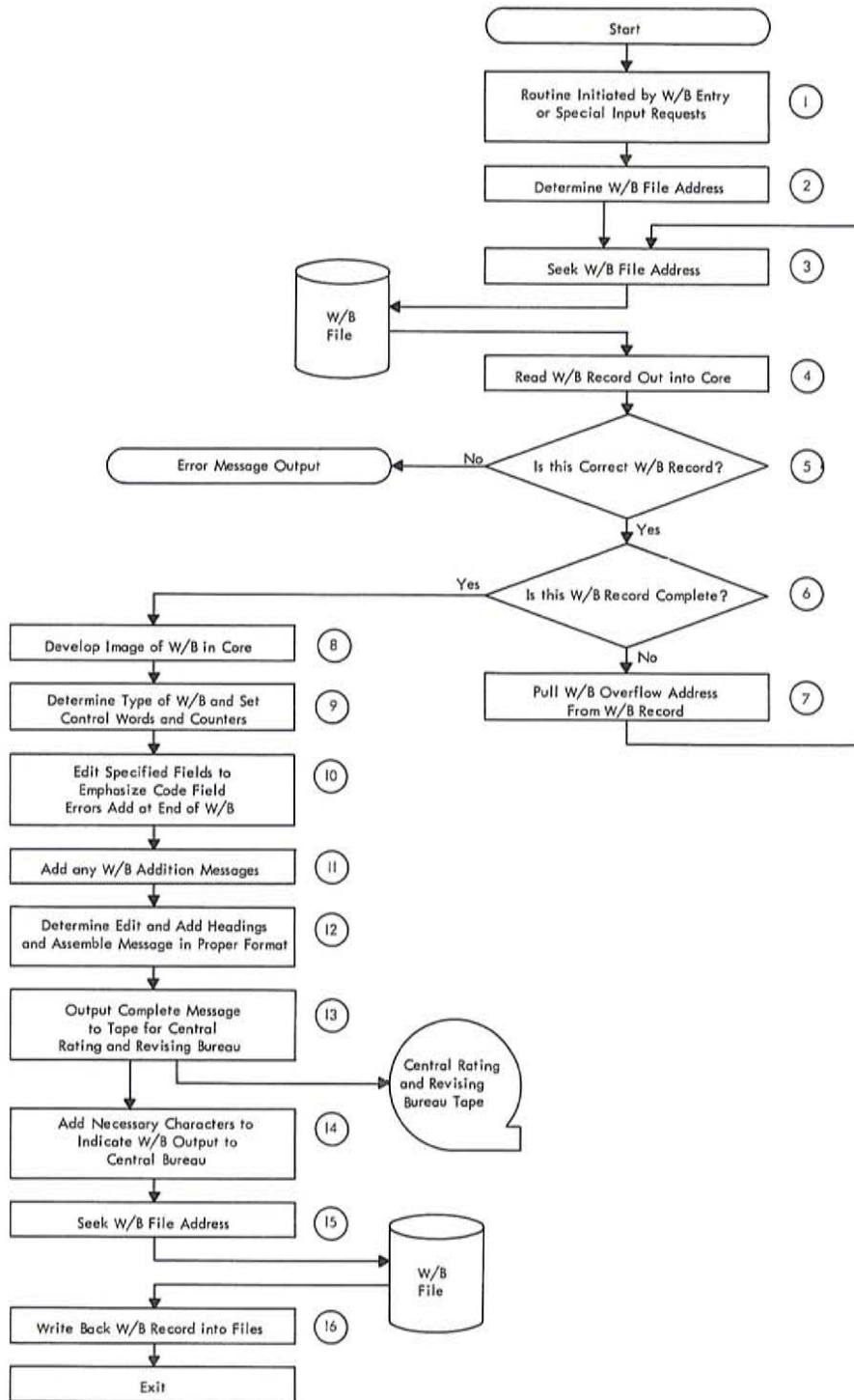

FIGURE 4-25 PROGRAM DESCRIPTION - OUTPUT W/B TO TAPE (ROUTINE #2)

addition from the input message is identified and either replaces information listed in the specified fields, or simply inserts new information in blank field areas. When the revised and correct waybill is completed, a field in the input message will contain characters which will indicate whether the freight bill should be prepared or deferred. If the freight bill is to be output, the fields of the waybill needed to develop a freight bill are defined and listed. The fields are determined by the waybill format and each field is identified by a code which is used as the argument in a "Table Look-up Equal" operation. The table contains the field code and the address of the first Record Definition Word. The Record Definition Words determine the area in core storage in which the specified field is contained. For each freight bill field in the list, the corresponding waybill field is transferred to a second core storage area where the freight bill format is being developed. The patron codes are pulled from the Waybill Image; these codes contain characters which define the Regional Center (San Francisco, Los Angeles, Houston, Portland) and the agency responsible for this patron. This code is added to the freight bill record so that further processing can be readily accomplished.

A freight bill number from a sequential series will be assigned and placed in both the freight bill and waybill. This processing is shown as blocks numbered 1 through 12 in Figure 4-26, Routine # 3, Waybill Revision and Freight Bill Input.

The waybill record contains a character which indicates whether or not the car has gone off-line. In the event the car has gone off-line, the waybill record can now be cleared from the disk files and written onto a tape for historic records. First, the Empty Waybill addressing chain must be adjusted to include this waybill file record address, since it is now free. The next Empty Waybill file address is stored in a specified core storage location and this is removed from core storage. This procedure ensures that the most recently cleared waybill file address is always stored in the core storage location, and the address of the next Empty Waybill file record is stored in the Empty Waybill file record. The revised and reviewed waybill record is assembled into the proper format for tape, and the headings necessary for future tape operations are added. Finally, the freight bill and waybill are written on their respective tape units. If the waybill is local prepaid, two freight bills will be written on tape; one for the shipper and one for the consignee. The now Empty Waybill file record contains a character that indicates it is vacant. The waybill file address of the next Empty Waybill file record is written back into the disk files after the record address has been accessed. In the event the car has not gone off-line, or that no freight bill is to be output, the Image of the Waybill is reprocessed, as before, to develop a file record. The waybill file address is accessed and the record is written back into the disk file. This processing is shown as blocks numbered 13 through 22 in Figure 4-26, Routine # 3.

The unreviewed waybill record may have contained a demurrage file address of a demurrage record. Since the waybill had not been received and revised, the correct patron code would probably not be in the waybill record at the time the car was released after loading or unloading. Therefore, if the waybill record had not been listed as reviewed at the time the car was released, the demurrage file address would have been listed in the waybill record for future action after review. The demurrage file address is pulled from the waybill record, the file is accessed, and the demurrage record is read into core storage. The demurrage record contains a character which determines

whether this patron is an average agreement or straight demurrage account. If the patron is a straight demurrage account, the difference of spot and release times is computed and the necessary demurrage charges, if any, are also computed. If the patron is an average agreement account, the difference between spot and release time is computed and the credit or debit times to be included in this patron's account is determined. The results of these computations are developed into a demurrage record which contains the patron codes and other necessary information; the demurrage record is then written on tape. If this car has not gone off-line, it has a car file record which contains the demurrage record's file address. Therefore, the car file address is pulled from the waybill record and the car file is accessed. The record is read into core storage and the demurrage file address is deleted from the car file record. The car file is again accessed and the updated car record is written back into the disk file. The program then exits and notifies the supervisory program that this core storage area is available for other processing. The processing is shown in blocks numbered 23 through 39 in Figure 4-26, Routine # 3.

The programs used to process waybills and freight bills were analyzed by using a sample waybill form AAR-98 containing approximately 550 characters of information. The system will require other similar programs to handle other forms of waybills. These programs will correctly define the length and fields of each of the waybill forms. Many of the detailed exception routines have not been included in these Block Diagrams. The details of these routines will depend upon the specific requirements of the Southern Pacific Company.

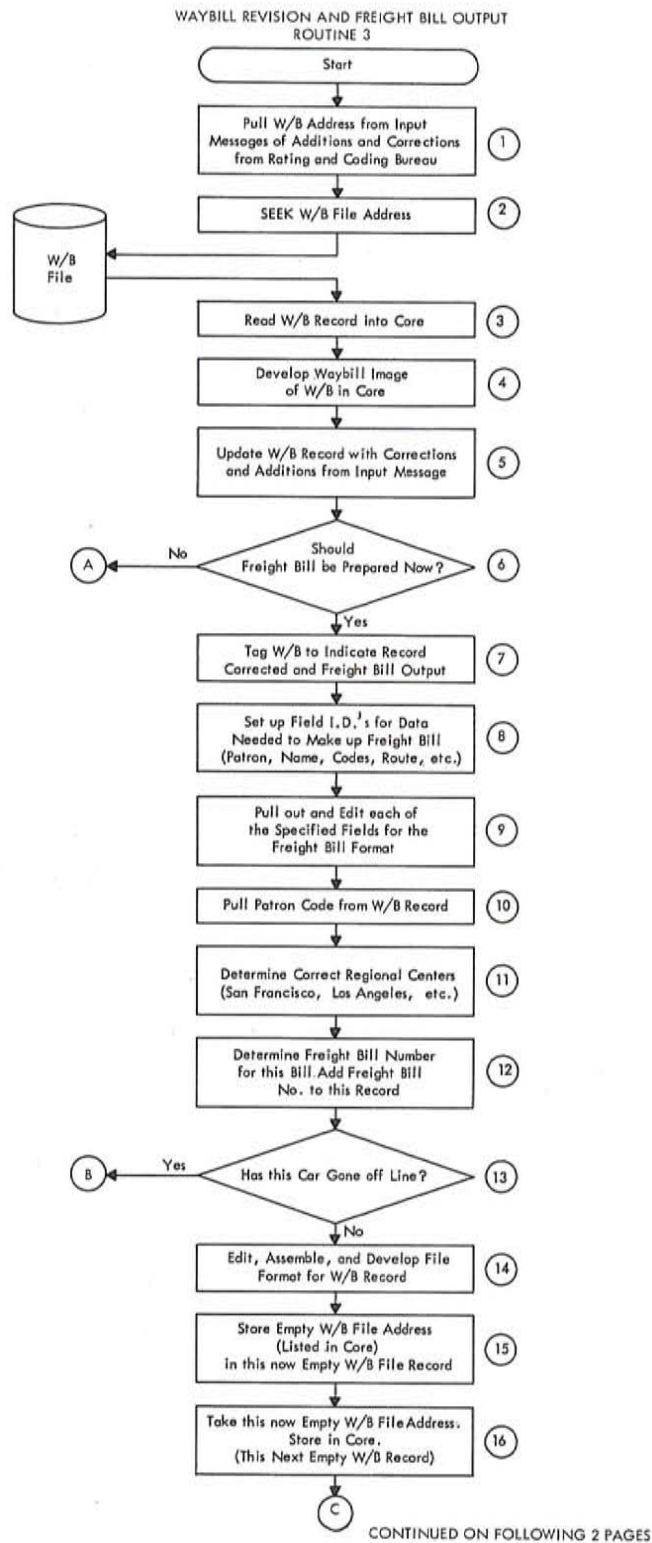

FIGURE 4-26 PROGRAM DESCRIPTION - WAYBILL REVISION AND FREIGHT BILL OUTPUT (ROUTINE #3)

WAYBILL REVISION AND FREIGHT BILL OUTPUT(CONTINUED)

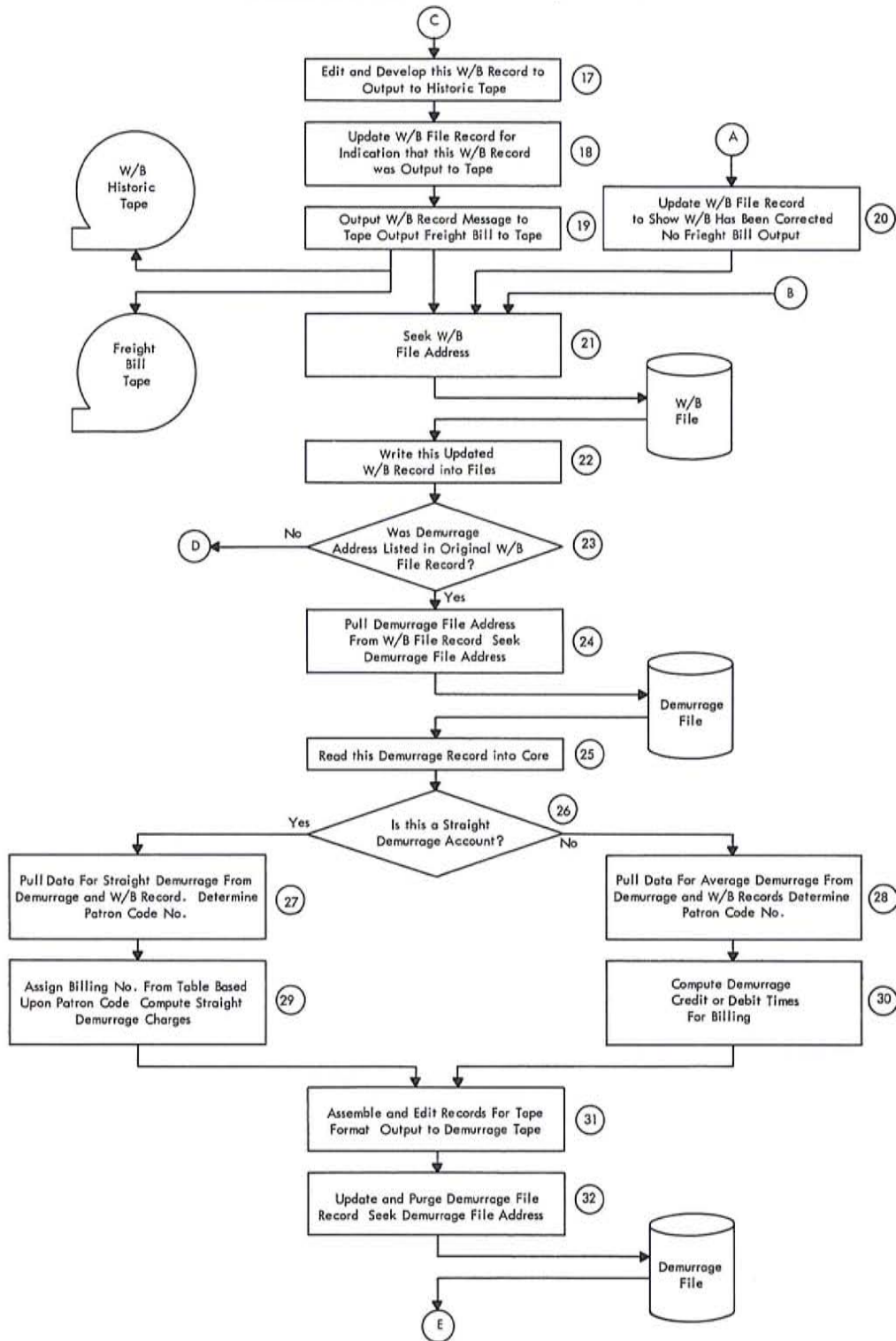

FIGURE 4-26 (CONTINUED)

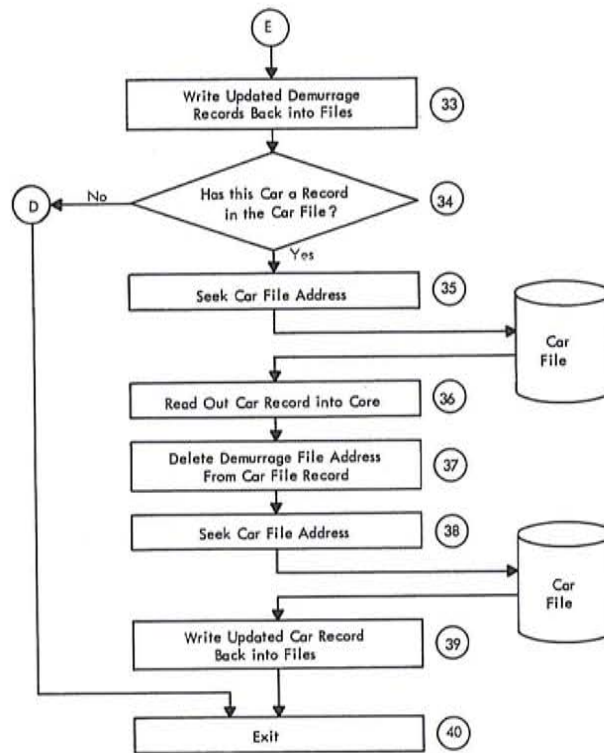

FIGURE 4-26 (CONTINUED)

EXAMPLE OF OPERATING PROGRAMS FOR TRAIN MOVEMENT

General

The operating area programs accept a dispatcher's initial train call to set up a train record and enter a train schedule, train number, and the locomotives to be used. This program provides data request cards to the yard, which act as headers for consist, crew, and locomotive data. Departure time is punched into the data field of the departure time header. Each header card is followed by its detail cards (if any) which cause the appropriate program to update the files concerned. When the programs initiated by the four data request cards have been completed, the departure report is sent to the dispatcher. The actual departure time, actual locomotives used, and actual consist description and other data are included.

After the departure report is received, the dispatcher may enter an intermediate call or a schedule-revised message. The effect of each is to output an advance consist and data request card to the next yard. The schedule revision message has the additional effect of allowing the dispatcher to change scheduled arrival and departure times at subsequent yards.

When the train arrives at an intermediate or terminating station, the arrival time, work performed enroute, locomotive assignment, and crew off duty programs accept the headers and detail cards and update the appropriate files. When the data is complete, the wheel report is compiled and a Check of Train Data is performed.

INITIAL CALL

The initial call is typed from the dispatcher's office. This message specifies:

1. A train number, and call time.
2. Suggested locomotive units.
3. An originating consist description.
4. A schedule, including arrival and departure times and estimated numbers of cars and weights.

The program performs the following functions:

1. Transmits the information from the call to the appropriate yards.
2. Accumulates a total figure horsepower for output on the locomotive header card, and a total weight figure for the train files.
3. Forms a skeleton record in the train file for this train.
4. Outputs information request cards to the yard.
5. Places open data references in the yard file for use in yard summaries.

Program Description (Initial Call)

Blocks 1-3 The first four letters of the dispatcher's call are a code which is used to obtain the Initial Call program (See Figure 4- 27). The message is then edited for correct format.

Blocks 4-12 In block 4, a table is called from the file which relates station numbers to the line and I/O unit address. Blocks 6 through 11 look up the line address and I/O unit address of each yard involved. A message is sent to each yard indicated in the call; thus, all yards are alerted that a train movement is to occur and are given basic information about it.

The message contains:

1. Consist description.
2. Station numbers of crew change points.
3. Scheduled arrival and departure times.
4. Estimated total gross weight and number of cars.

All of this information is obtained from the initial call.

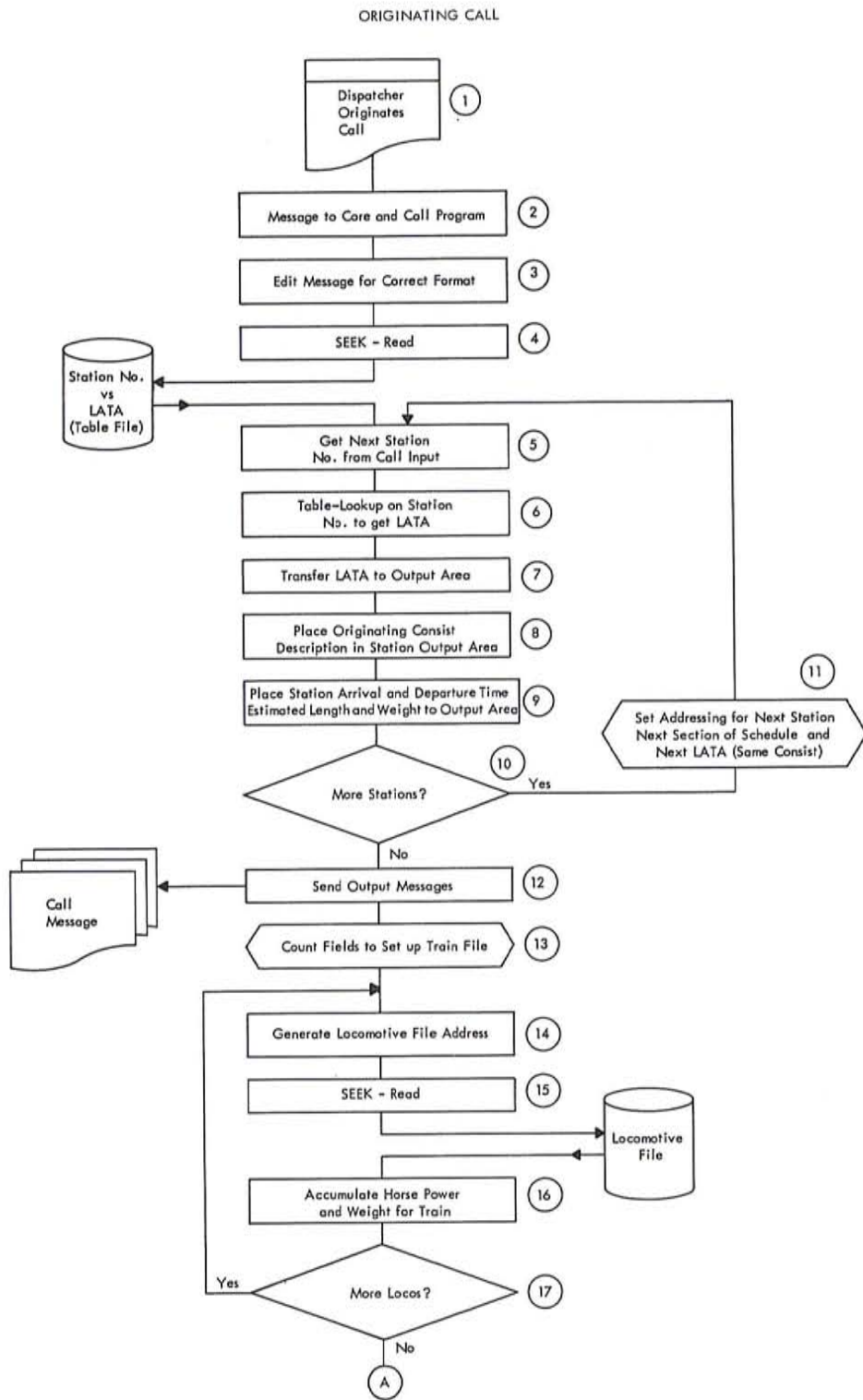

CONTINUED ON FOLLOWING PAGE

FIGURE 4-27 PROGRAM DESCRIPTION - INITIAL CALL

ORIGINATING CALL(CONTINUED)

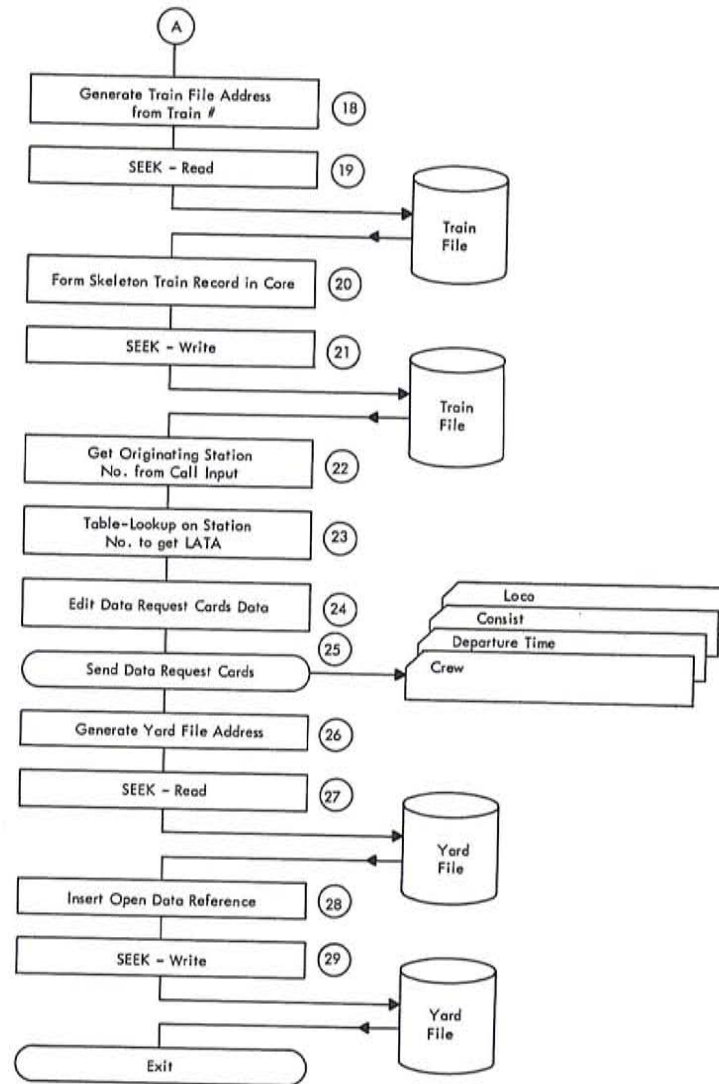

FIGURE 4-27 (CONTINUED)

- Block 13 The file record for a train consists of sections of variable length; therefore, the stations and locomotives shown in the call are counted and index registers are set in preparation to form the skeleton train record in core storage.
- Blocks 14-17 The first locomotive file address is generated and the record is read. In block 16, the total locomotive weight is accumulated for use in the skeleton train record. Block 17 tests for completion of the process.
- Blocks 18-21 The function of forming a skeleton record in the train file has three logical parts: generate the file address, form the skeleton record, and write the record. Blocks 18 and 19 show generation of the address. However, the actual generate subroutine contains the seek and read within it, and checks the record for vacancy. If it is not vacant, an alternate address is obtained. The address obtained is saved for writing the skeleton record and for use in the reference address portion of the header cards. Train file address generation is similar to the car file address generation except that the train number is used instead of car initial and number. In blocks 20 and 21, the skeleton train record is formed in an output area of core storage and is written in the train file.
- Blocks 22-25 The line and terminal address for the originating yard office, together with the data request card data, are formed into a message in the output area. These cards serve the dual purpose of requesting specific data, and acting as headers to inform the central processor as to what program is to be called to process the detail cards which follow.
- For such cases as departure time, where the quantity of information requested is small, the data required is punched into the data field of the header card; no detail cards are required.
- Blocks 26-29 This section of the program inserts an open date reference in the yard file. This is done by inserting the train file address in the proper sub-record area of the first physical record of the yard file.

INITIAL CONSIST

General

The consist deck contains a consist data request card, followed by block headers and yard cards. Thus each planned setout of a block of cars is indicated.

Operations performed include the following:

1. The record of this train in the train file is updated with a tag to show that the initial consist has been received.

2. The car record file address for each car, the station where the block was picked up, and the point where this block is set out are added to the record in the train file.
3. The car file references are removed from the yard file and the required summary information is updated.
4. Car records are updated to reflect responsibility and the time the car was put on the train.

The sequence of these operations is chosen to minimize the time this program is in core storage since it is relatively large.

Program Description (Initial Consist)

Blocks 1-6 A consist deck is received and entered into core storage, together with the program (See Figure 4-28). The format is edited to six words per card to facilitate the formation of queue lists, and the train file address is obtained from the header card reference address field. Program control is then transferred to the supervisory program to seek and read the train file record, and protect this file address from interference by other programs until the record is written back. The consist information request tag is then set to show that the consist has been received for this station.

Blocks 7-17 The originating consist program has a high volume of data to be processed, and requires a relatively large amount of core storage time. A relatively large elapsed time would be required to run the program if car file updating were done serially. However, the car file updating program permits overlap of seek operations.

In block 7, the car file addresses are placed so that there is a queue for each file module. In block 8, the supervisory program is given a request to seek and read all file modules. When a record is found and read into core storage, control is returned to the initial consist program. In block 9, the consist program determines which module was read and chooses the working area for that particular file module. Blocks 10 through 17 perform the required car file updating to show that the car is now on the train, and logical checks are made on the move. Other blocks update the train record now in core storage and prepare to update the yard responsibility file when it is called into core storage.

Blocks 18-21 Block 18 signals the supervisory program that a record is now updated and ready for the car file. The next event may be to return control to connector **(A)**, thus signaling that another car record has been read. A different working area is chosen and the consist program progresses to the point where control is again given to the supervisory program and a seek-write for the second car file address is requested. At this point, the supervisory program may return to the originating consist program and signal it that the first seek-write operation is completed.

INITIAL CONSIST

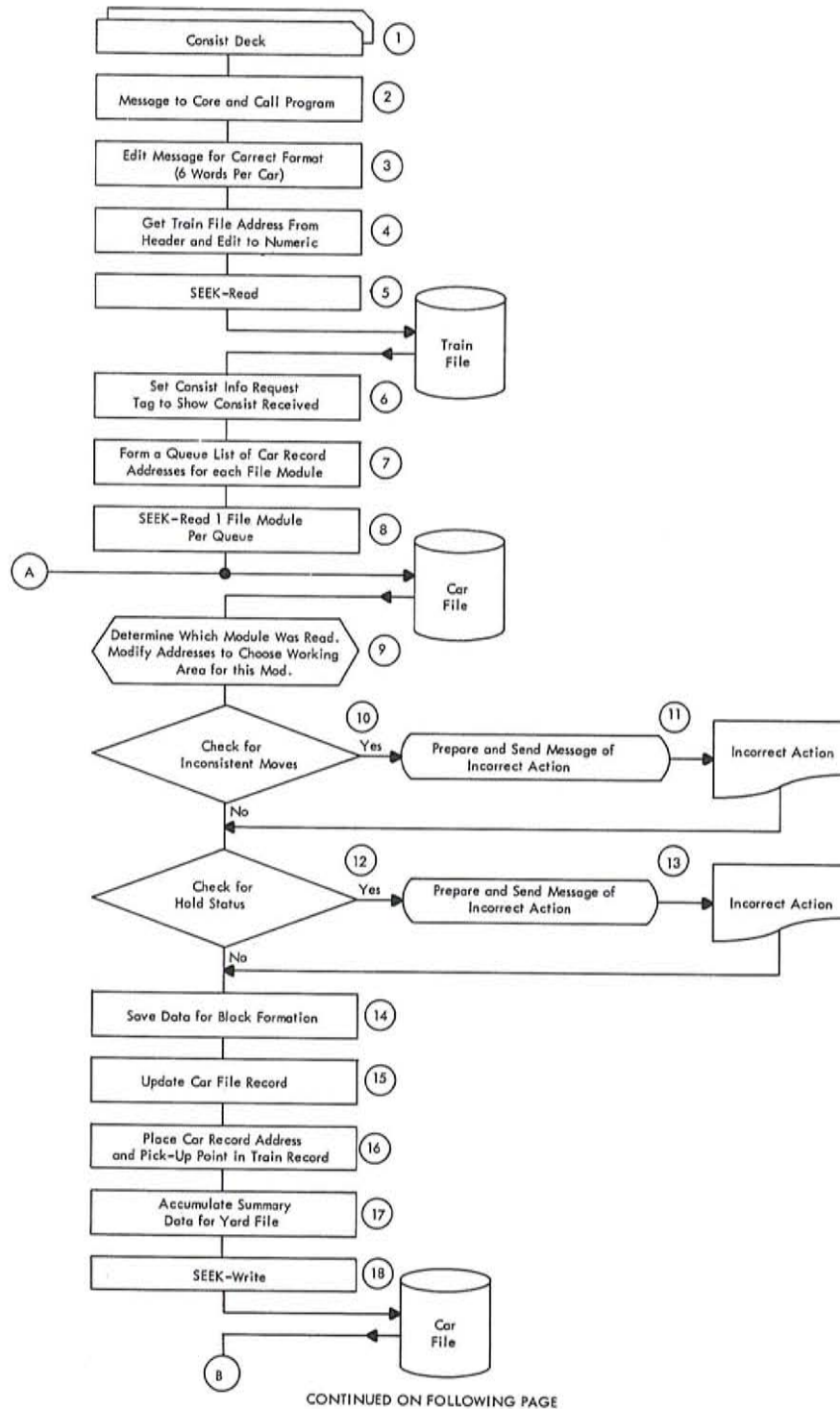

FIGURE 4-28 PROGRAM DESCRIPTION - INITIAL CONSIST

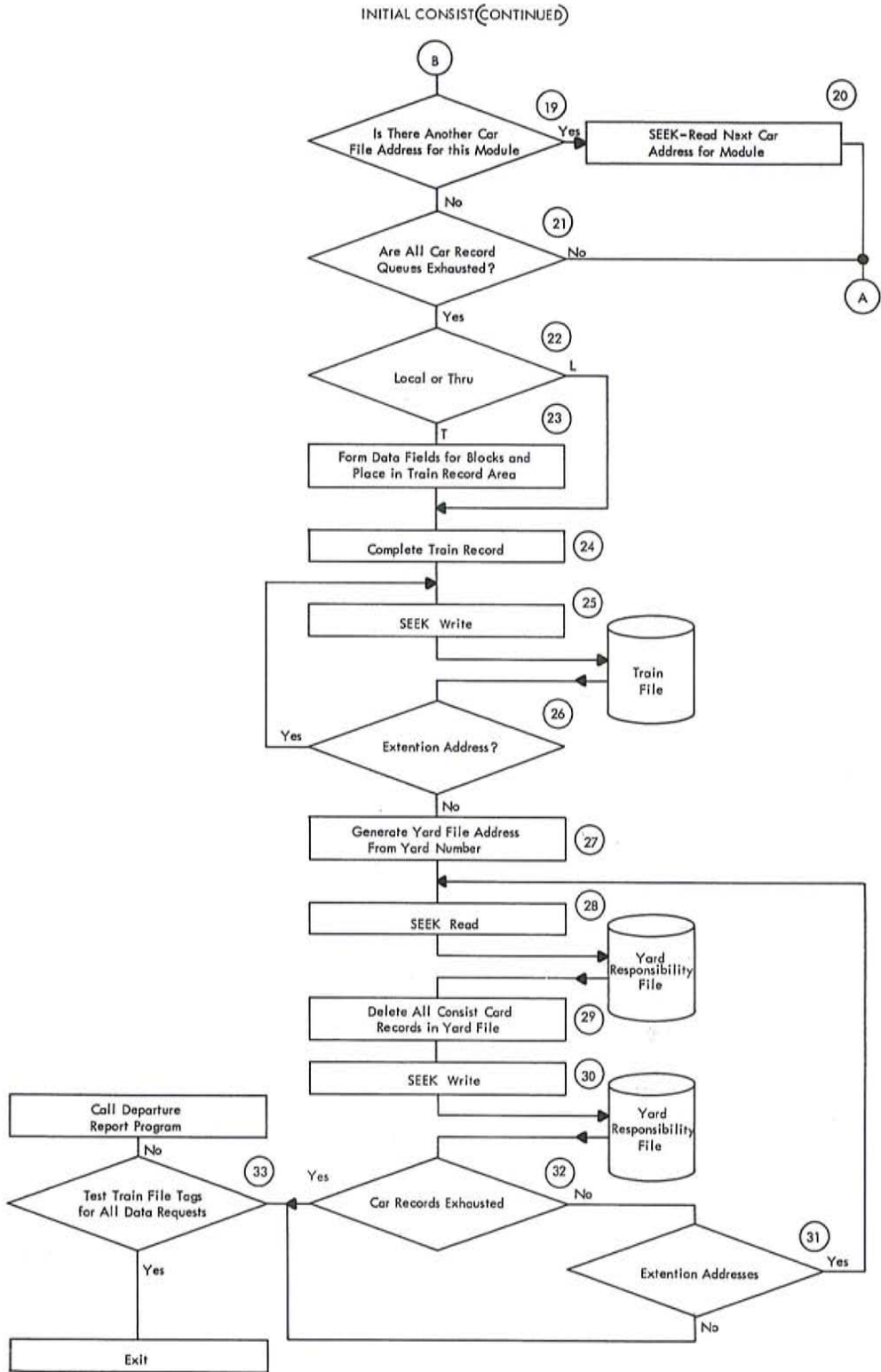

FIGURE 4-28 (CONTINUED) *Southern Pacific Company*

Block 19 and 20 test to determine whether there are any more cars for the first file module, and if so, requests a seek from the supervisory program. If the queue for this module is complete, control is returned to the supervisory program without issuing a seek, and the supervisory program will automatically return control to connector (A) when another record has been read. Block 21 allows consist processing to continue at connector (C) when the car records for all modules have been processed. Blocks 22 and 23 form a block sub-record area in the train file for a through train. These block sub-records contain the yard designation of the point at which the cars are to be removed from the train, and data required for the issue of block cards in the advance consist. Block 24 performs a consolidation of subrecords and replaces the consist description from the call report with a consist description from accumulated summary data compiled in Block 17. The train file is then written in Block 25. Blocks 26 through 32 update the yard responsibility file by removing car file references for each file record. Block 33 checks the flag in the train file for completion of Crew on duty, Departure time, and Locomotive programs. If these are complete, the departure report program is called.

LOCOMOTIVE ASSIGNMENT

General

The locomotive assignment programs perform the basic operations required to account for locomotive moves between stations. Another program is required to accept locomotive detail cards for locomotive set outs and terminations. This program is quite similar to the one shown in Figure 4-29, except that responsibility is transferred from the train to the yard where the locomotive is set out.

Program Description (Locomotive Assignment)

- Blocks 1-5 The locomotive header, followed by locomotive detail cards, is received. The supervisory program transfers the message to core storage and decodes a portion of the reference address to call the application program. The message is then edited for correct format (legitimate entries in data field) and the train file address is obtained from the data request card.
- Blocks 6-13 Addresses of locomotive records are generated for the locomotive numbers entered in the detail cards. A check is made to assure that this locomotive is reportedly in this yard at the time it is assigned to the train. If not, a Message of Incorrect Action is formed. The train file address is inserted in the locomotive record after removing the oldest of the last five previously-reported locations and replacing it with the current location. The total locomotive weight is accumulated for use in the crew off duty program, and the locomotive records are written back into file storage.

LOCOMOTIVE ASSIGNMENT

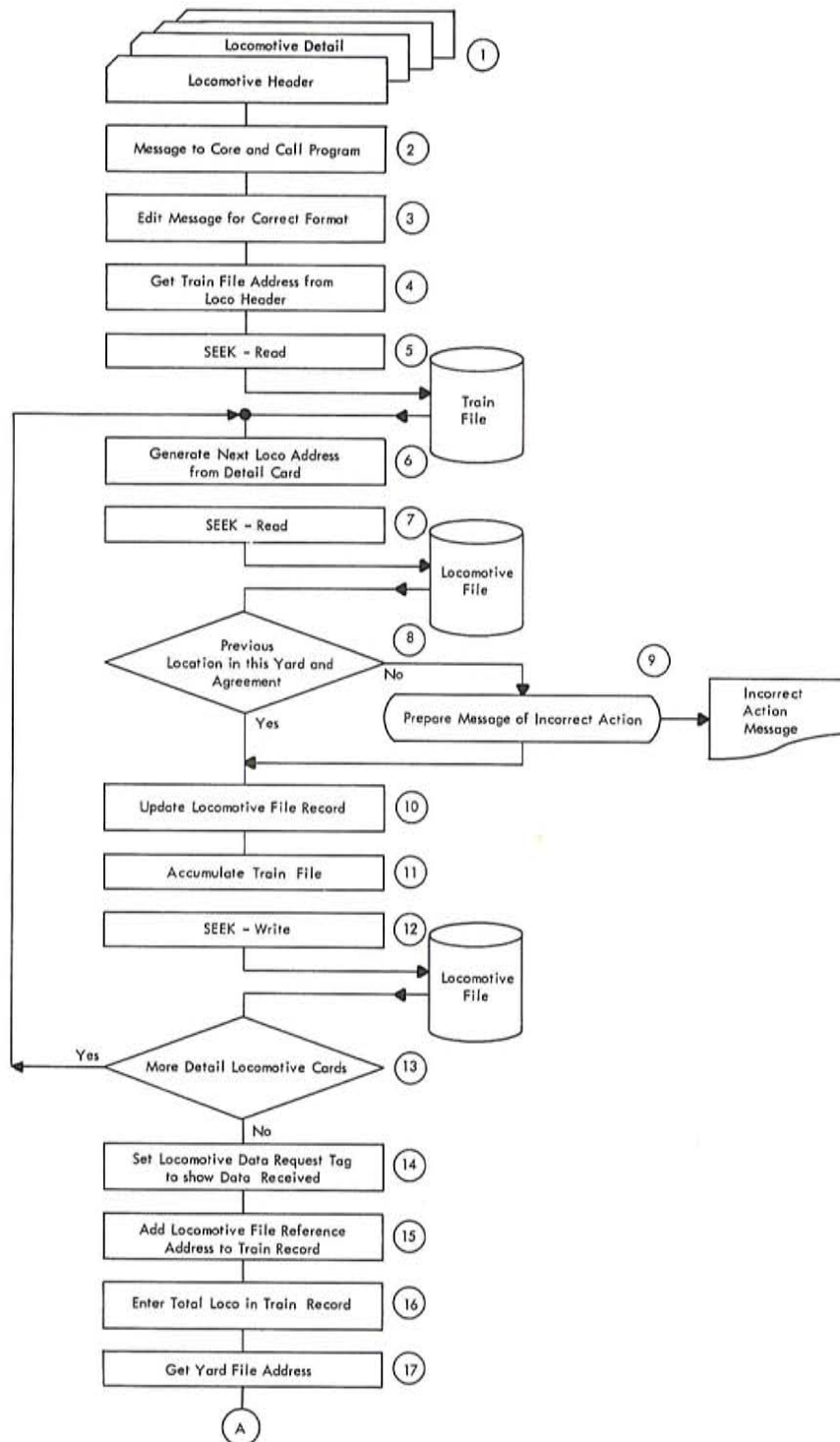

CONTINUED ON FOLLOWING PAGE

FIGURE 4-29 PROGRAM DESCRIPTION - LOCOMOTIVE ASSIGNMENT

LOCOMOTIVE ASSIGNMENT(CONTINUED)

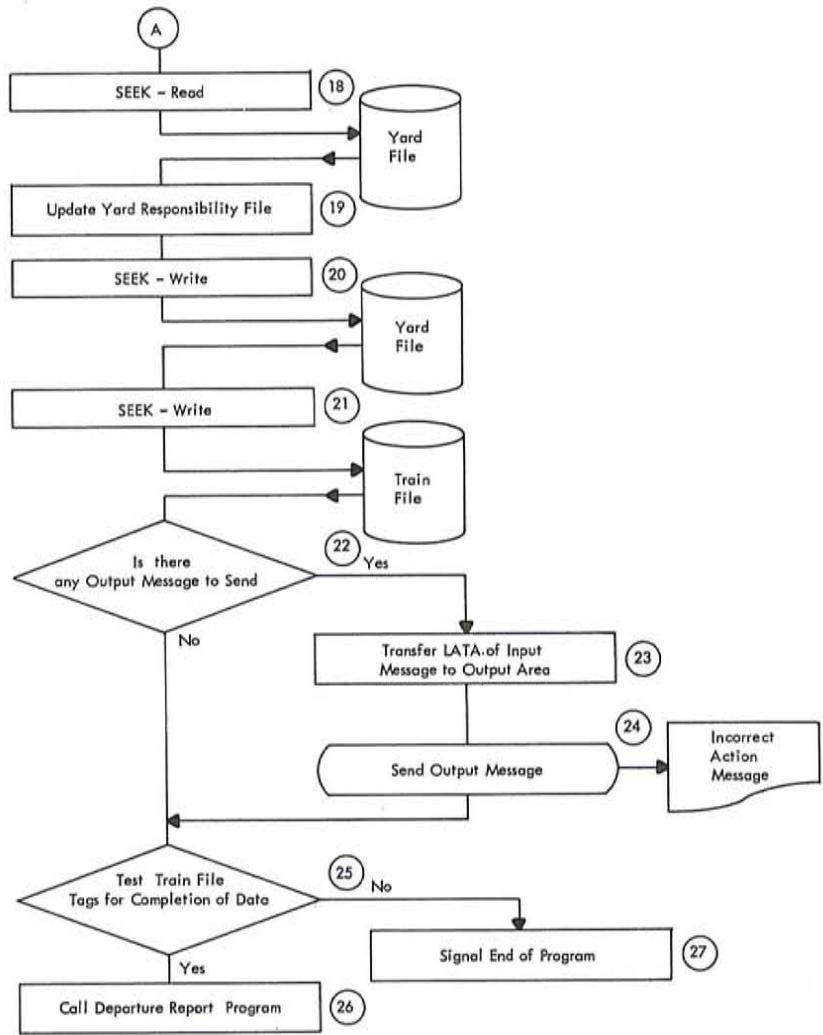

FIGURE 4-29 (CONTINUED)

- Block 14 The locomotive information request tag in the train record is updated to show that the locomotive data has been received.
- Blocks 15 & 16 A locomotive file reference address is placed in the train record for each locomotive. The total locomotive weight is entered in the train file.
- Blocks 18-20 The yard responsibility file is updated by removing the locomotive file reference addresses.
- Block 21 The updated train record is written back into file storage.
- Blocks 22-24 Incorrect action messages regarding locomotives (if any) are sent to the yard.
- Blocks 25-27 The departure report program is called if the requested train data is complete. This includes consist, crew, and departure time.

CREW ON DUTY

General

Crew on duty data is received by the central processor, and the train file and crew file are updated.

Another program, which is similar to this one, accepts crew off duty data and supplies the crew file with such data as:

1. Maximum number of cars handled.
2. Local or thru train.
3. Maximum locomotive weight (for crew records with a service code of Engineer).
4. On and off duty times.

Data for six work days is retained in the crew file.

Program Description (Crew on Duty)

- Block 1 A crew call header card, followed by crew detail cards, is transmitted from the yard office (Figure 4-30). Each crew card contains a "service" field of 17 characters in the remarks area of the crew card which specifies the job description of the crew member. If the crew member is to serve in a different capacity, a 2-digit code is entered in the data field to indicate the function actually performed. The data field also contains sub-fields for off duty and on duty times, and a 2-digit claims code. The off duty sub-field should be blank at this time.

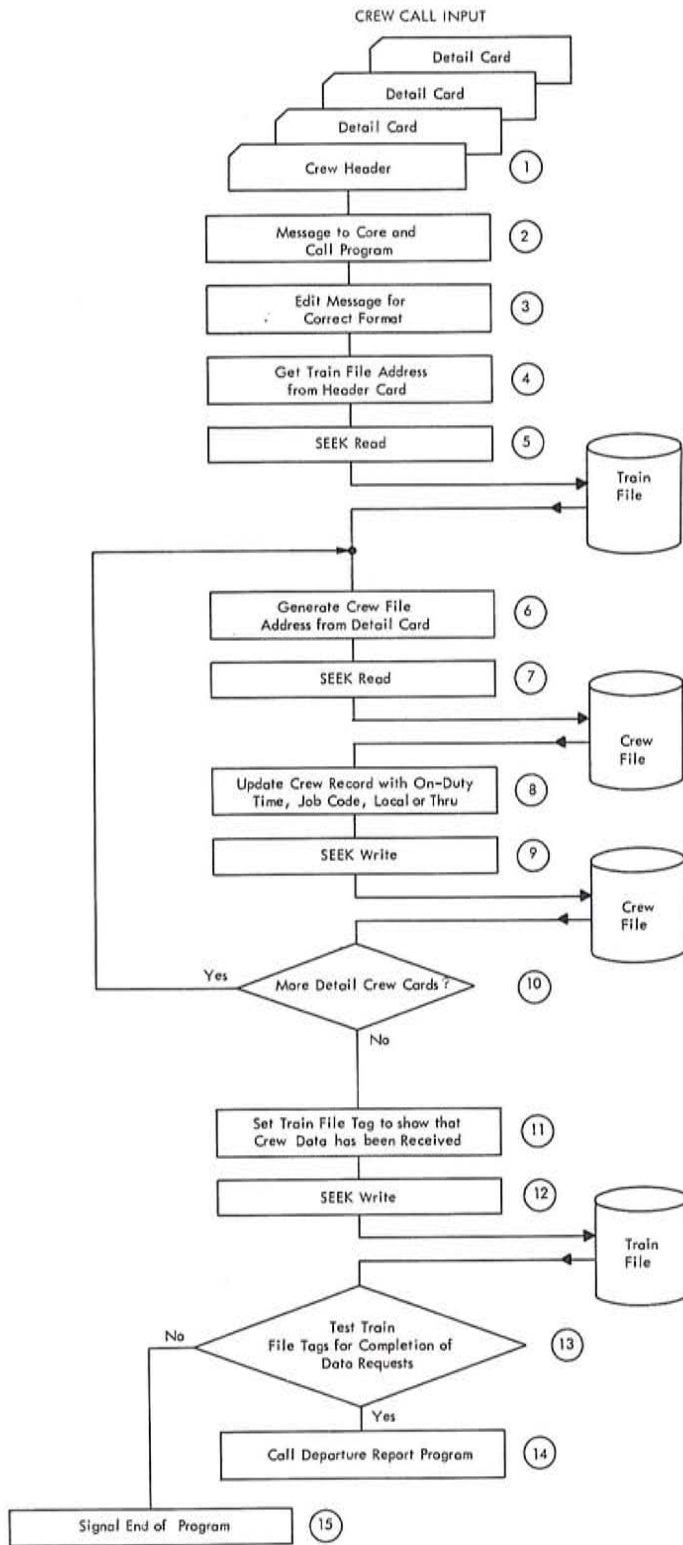

FIGURE 4-30 PROGRAM DESCRIPTION - CREW ON DUTY

- Blocks 2-5 The reference address in the data request card is used to obtain the crew on duty program and to call the train record. The message is edited for correct format to assure that the sub-fields of the data field are correctly aligned.
- Blocks 6-10 The crew record address is generated from the employee numbers punched in the detail cards, and the file record is read. The on duty time is also placed in the crew record together with a code for local or thru. The train number is also placed in the crew record and the updated record is written back into file storage. The process is repeated until the crew record for each detail card is updated.
- Blocks 11 & 12 The train file data request tag is set to show that the crew call data has been received. The actual crew file addresses are inserted in the train record. The updated train record is written back into file storage.
- Blocks 13-15 The train file data request tags are tested for completion of train data at this yard; if they are completed, the departure report is called; if not, end of program is signaled.

DEPARTURE TIME

General

The departure time is punched in the data field of the departure card. Thus, the departure time is available to update the train file.

Operations performed include the following:

1. Obtain the train record.
2. Replace the estimated departure time with the actual time in the train file.
3. Update the car file to show the actual departure time for cars originating with the train if the consist has been entered and if actual departure time differed from the schedule.
4. Write the train record back into the train file with the updated departure time.
5. Determine whether all data requests are satisfied, and if so, call the Departure Report Program.

The sequence of operations is chosen to minimize accesses to the car file by performing a car record update only when required by a change in the schedule set by the dispatcher in the originating call.

Program Description (Departure Time)

- Blocks 1-4 The departure time header is received by the central processor (Figure 4-31). A portion of the reference address field is decoded and the departure time program is called. Another portion of the reference address field yields the train file address. The train file is then read into core storage.
- Block 5 The train file data request tag is set to show that the departure time has been received.
- Blocks 6 & 7 Two checks are made to determine if a car file update is required. The "NO" path from block 5 assumes the consist program will update the car file later. The "YES" path from block 6 causes a further test. If the schedule was met, no further car file update is required.
- Blocks 7-15 This section (car file update) is similar to other programs making many accesses to the car file. A queue is established for the car records to be accessed for each module. Connector (A) and the output of Block 12 are points at which the completion of a read or write operation for a car record in any file module allows processing to continue. When the write operation is completed, the address for another record (if there are more) is taken from the queue and the supervisory program gains control to access and read another car record. This procedure allows the car file update operation to progress as if the processing for the car records associated with each file module were a separate program. This feature takes full advantages of the multiprocessing capability of the supervisory program.
- The mechanism of blocks 9 through 15 is more fully explained in description of the originating consist.
- Block 16 Actual departure time is added to the train record. A tag is also set to show that this is an actual time. This is the time that will appear on the departure report to the dispatcher.
- Blocks 17-20 The updated train record is written from core storage back into file. The completeness of the departure report data is determined; if it is complete, the departure report program is called.

This written description, and the flow chart of Figure 4-31 cover the case of departure time for the originating yard. For an intermediate yard, block 8 would read "form a queue list of Car Record Addresses for each file module for those cars placed on the train at this yard and all cars not in blocks."

DEPARTURE TIME

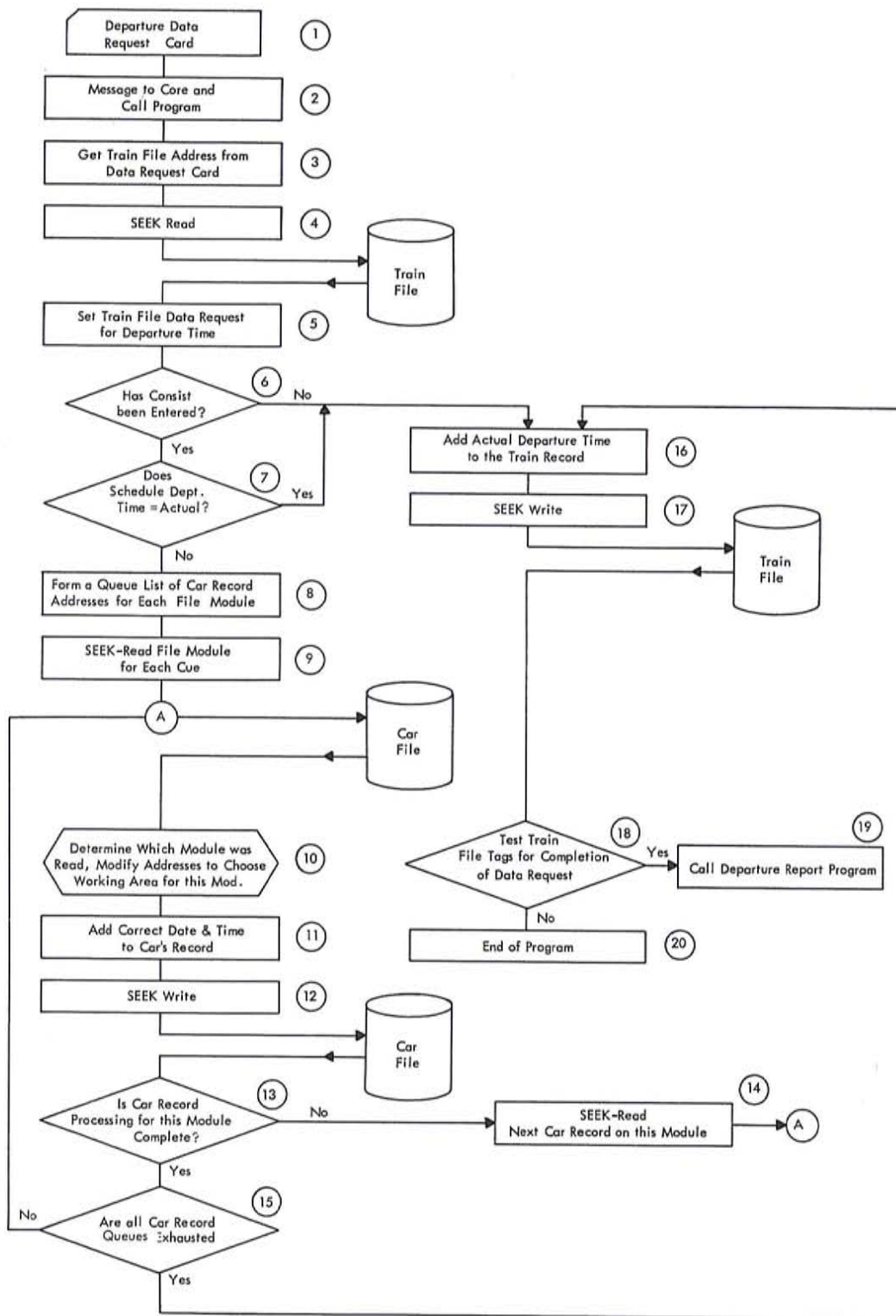

FIGURE 4-31 PROGRAM DESCRIPTION - DEPARTURE TIME

DEPARTURE REPORT

General

The departure report is shown as a separate program to avoid duplication in explaining it. For actual coding purposes, however, it could be included in the programs that call it, thus saving the file accesses required to call the program, read the train file, and in some cases, to read and write the yard file.

Functions:

1. Prepare the Departure Report for the dispatcher.
2. Delete the open data entry for requested information regarding the departing train.

Program Description (Departure Report)

- Block 1 This program is triggered by completion of the programs called by the data request cards (Figure 4-32). Block 1 shows the list of programs which call the departure report at the originating station. At an intermediate yard, crew off duty, work performed enroute, and arrival time are added to the list.
- Block 2 The program is called into core storage. A link is established from the previous program to give the departure report program, the train file address and the station that returned the data request card. The core storage area reserved for the previous program is then released and the link is treated as an input message.
- Block 3 The train file address is obtained from the program linkage message.
- Blocks 4-7 The train file is read and the departure report is formed from the train record and sent to the dispatcher. It consists of the code DEPT, followed by the train number, call time, locomotives assigned, consist description, and a line for each station showing the station number, arrival and departure times, number of loaded cars, number of empty cars, and block destination for each block for a maximum total of 6 blocks per station. The information concerning the blocks comes from block headers and an accumulation of loaded and empty figures from the subrecord fields of each car in the train file.
- Blocks 8-12 The yard file is addressed from the linkage message and the file address for this train is deleted from the yard record; this indicates that all open data requests for information regarding this train have been fulfilled. The updated yard record is then written back into file, end of program is signaled and the output message is sent.

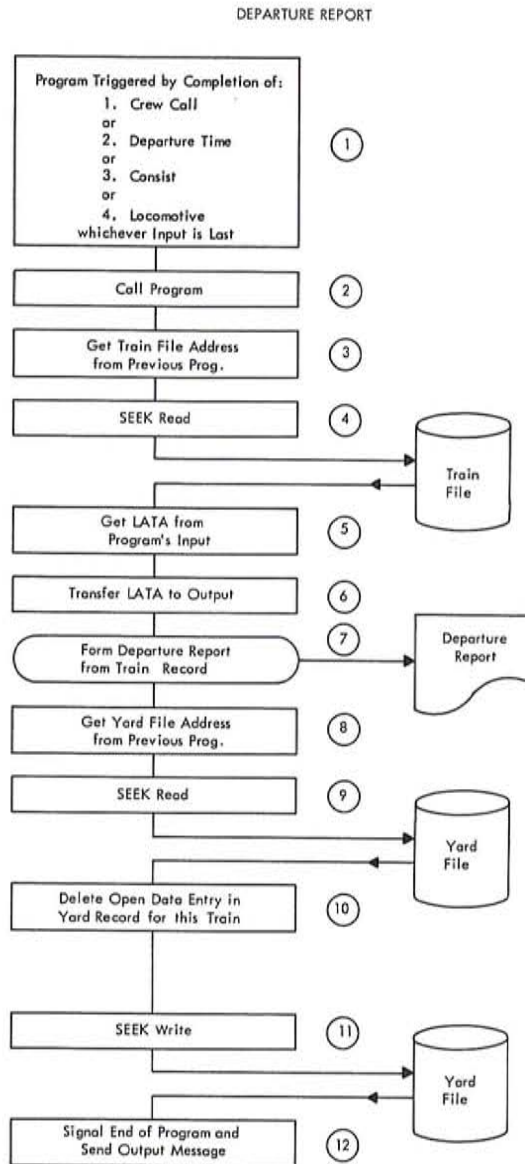

FIGURE 4-32 PROGRAM DESCRIPTION - DEPARTURE REPORT

SCHEDULE CONFIRMATION - ADVANCE CONSIST

General

The dispatcher inputs a schedule revision message or a schedule confirmation message. Both messages call this program, and both messages cause an advance consist and data request cards to be sent to the next yard. The schedule revision message, however, has the additional effect of sending the revised schedule to all subsequent yards. The format is the same as the schedule message sent by the call

program, and the data for it is obtained from the dispatcher's schedule-revision message which has a format similar to the initial call message.

Operations performed are:

1. Schedule-revision output messages are formed and sent to subsequent yards and estimated times are changed in the train file.
2. Data Request cards are formed and sent to the next yard shown in the train file.
3. A consist message, consisting of yard cards and block cards, is obtained from the train file and car file, and is placed in the output area in train order.
4. The data for service request cards is obtained from the service request file and placed in an output area immediately after the consist. The consist and the service requests are then sent together as the advance consist.
5. An open data request entry is placed in the yard file of the consisted yard to show that data request cards have been sent to the yard. An additional entry is made for the service request cards.

Program Description (Schedule Confirmation - Advance Consist)

Blocks 1-5 The schedule revision message and the schedule confirmation message both have the same format (Figure 4-33). The first four characters are used by the supervisory program to call the advance consist program; both codes call the same program. However, the confirmation need contain only the message code, train number, "L" or "T" for local or thru, and call time. The locomotive numbers of four suggested locomotives may be included for output in the remarks field of the locomotive header. The schedule-revision message format has the same fields as the confirmation, plus the consist description and new schedule for each intermediate yard and the terminating yard. This information contains station number, arrival time, departure time, estimated length (total cars), and estimated gross weight. Block 3 edits this input for correct format. Blocks 4 and 5 generate the train file address and read the train file into core storage in a manner similar to car file address generation, except for the use of train number instead of car initial and number as the input.

Blocks 6 -17 Block 6 tests the message code to determine whether this is a schedule confirmation or a schedule revision. Block 7 modifies the estimated times in the train file. In blocks 8 through 17, a schedule revision output message is formed for each succeeding yard in a manner similar to that employed in the initial consist program. The format is also the same, except SRVN (Schedule Revised Notice) instead of TCLN (Train Call Notice) appears at the beginning of the message. Block 17 causes the messages to be transmitted.

SCHEDULE CONFIRMATION - ADVANCE CONSIST

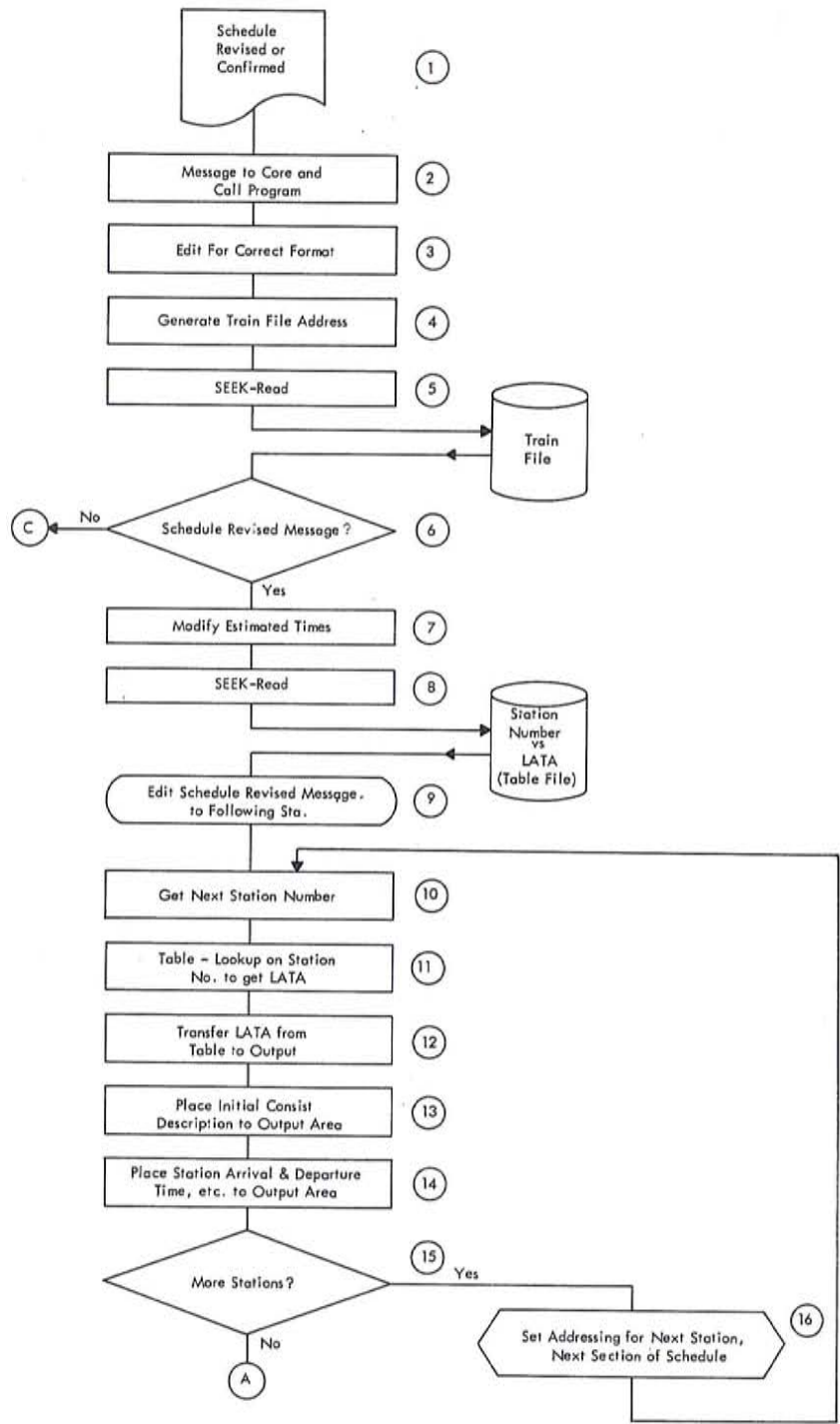

CONTINUED ON 3 FOLLOWING PAGES

FIGURE 4-33 PROGRAM DESCRIPTION - SCHEDULE CONFIRMATION- ADVANCE CONSIST

Blocks 18-22 Data Request cards are formed and sent to the consisted yard. The next arrival station is obtained from the train record, and the line and terminal address is found by table lookup and transferred to the output area. In block 21, required data request cards are formed from the train record, and tags are set in the train record to indicate which data requests are being made. Block 22 shows the output of the required data request cards for the case of the consisted yard being an intermediate yard at which a crew change is required. When the consisted yard is the terminating yard, only four data request cards are sent, as noted on the flow chart. At an intermediate yard, the crew and locomotive data request cards may not be formed in certain cases. For these cases, the information request tags in the train record are not set for an open data request.

Blocks 23-45 - Obtain detail consist information from car file:

Blocks 23 through 35 - Form queue list for utilization of all modules in getting required car records from car file.

Blocks 23 through 28 (Main Path)- This path performs the entire function of forming the queue list for accessing the car file for the advance consist of a terminating station for through trains.

Blocks 29 and 30 (Intermediate Yard) - These decisions cause the output of detail cards for intermediate stations where cars are removed from a through block which is destined for a station beyond, or before the station being consisted.

Blocks 31 through 35 (Local Trains) - This path performs queue formation for the advance consist of a local train.

Blocks 36 through 45 - Obtain consist data from car file:

Blocks 36, 37, 43, 44, 45 (Car File Access Control):

Car file access is initiated by giving the supervisory program a command to seek and read one car record from each module, and return control to the advance consist program at the completion of the seek-read operation for each module. Control is then given to the supervisory program, and car file access proceeds as if there were a separate program for the car records found in each module. Thus, only one working storage area is required per file module, and only one input storage area is required per module for file read.

Blocks 38 through 42 (Form Consist Items in Core):

A yard card image is formed from the car record. A table lookup is performed on final destination station to obtain a tag number for use in the consisted yard. This Tag Number is included in the yard card image. Output card images are formed instead of saving the whole car record to conserve core storage space. The Service Request file address is obtained from the car record if there is a service request, and placed in the service request queue.

SCHEDULE CONFIRMATION - ADVANCE CONSIST (CONTINUED)

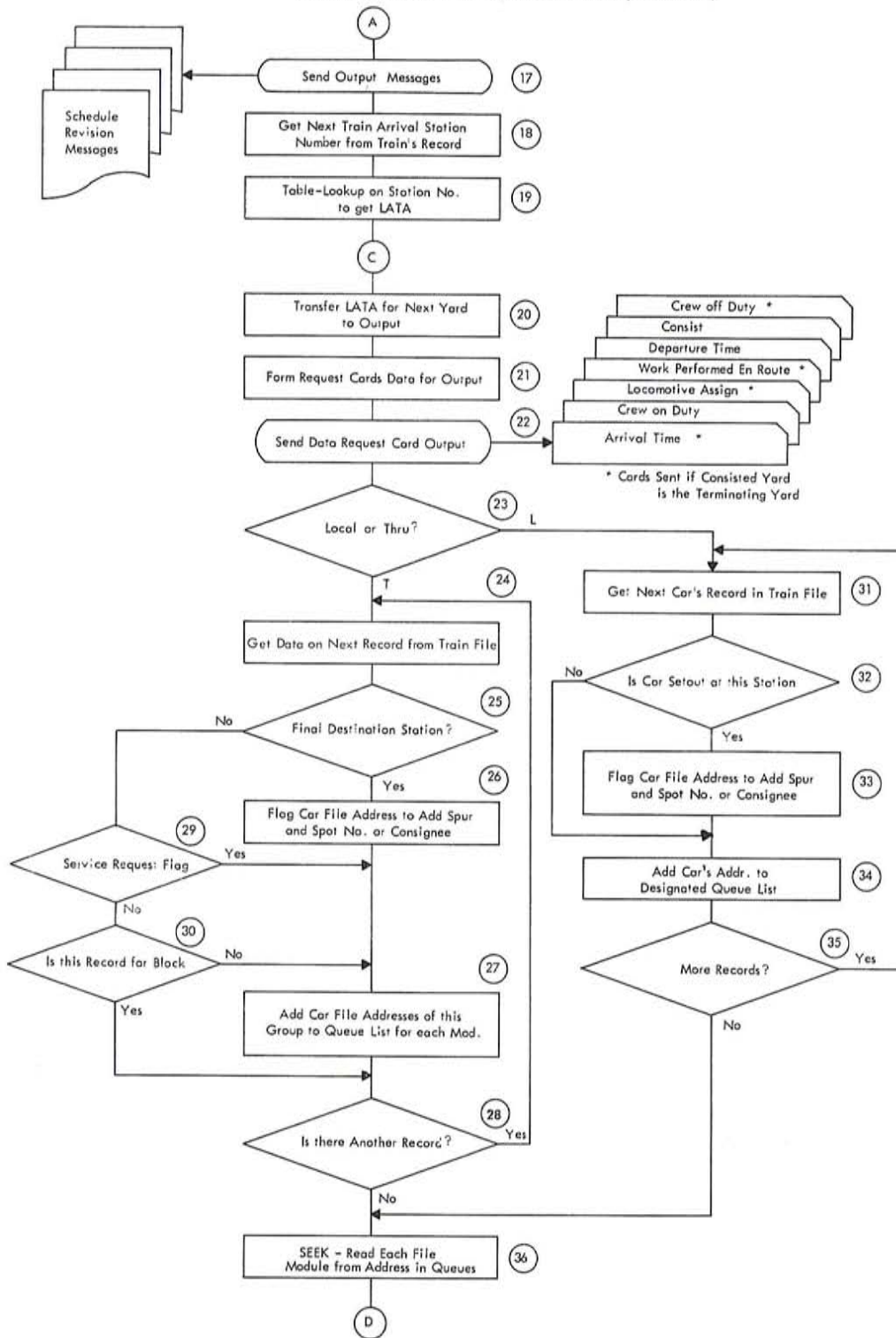

FIGURE 4-33 (CONTINUED)

Southern Pacific Company

SCHEDULE CONFIRMATION - ADVANCE CONSIST (CONTINUED)

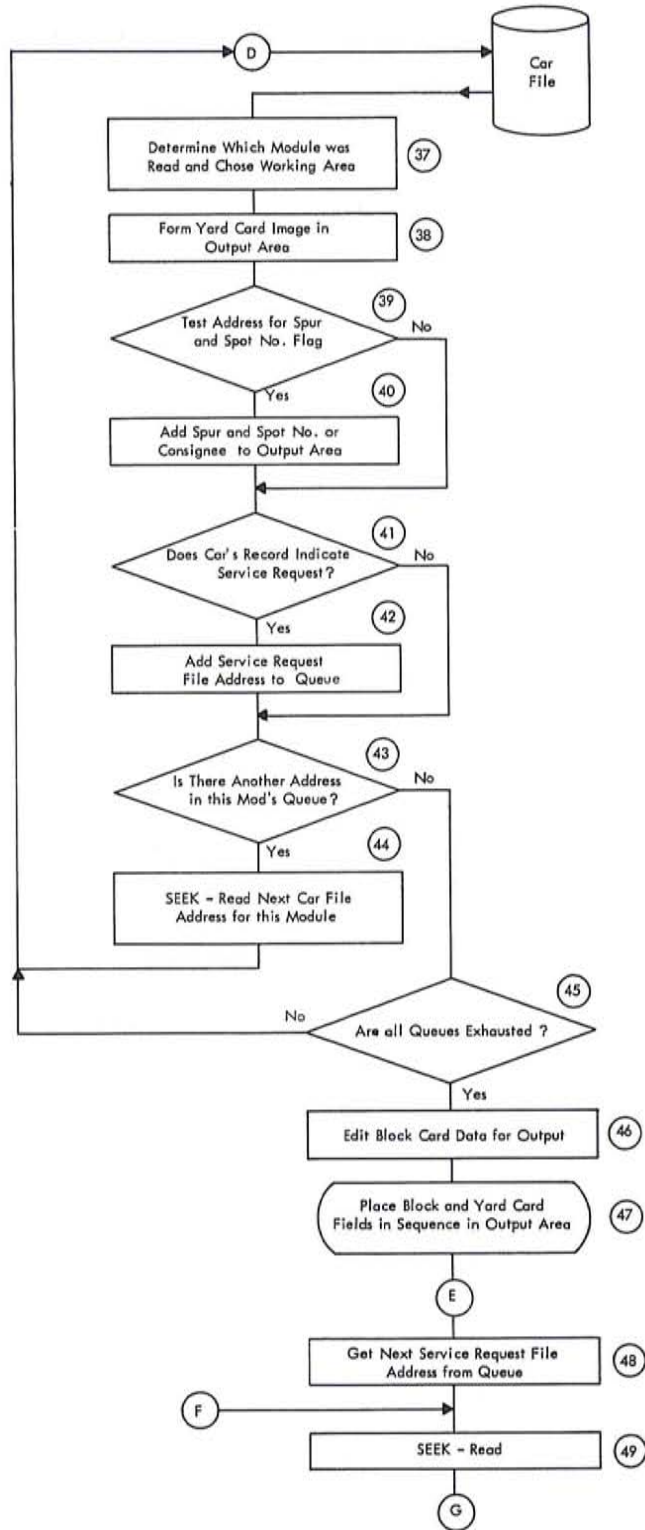

FIGURE 4-33 (CONTINUED) *Southern Pacific Company*

SCHEDULE CONFIRMATION - ADVANCE CONSIST (CONTINUED)

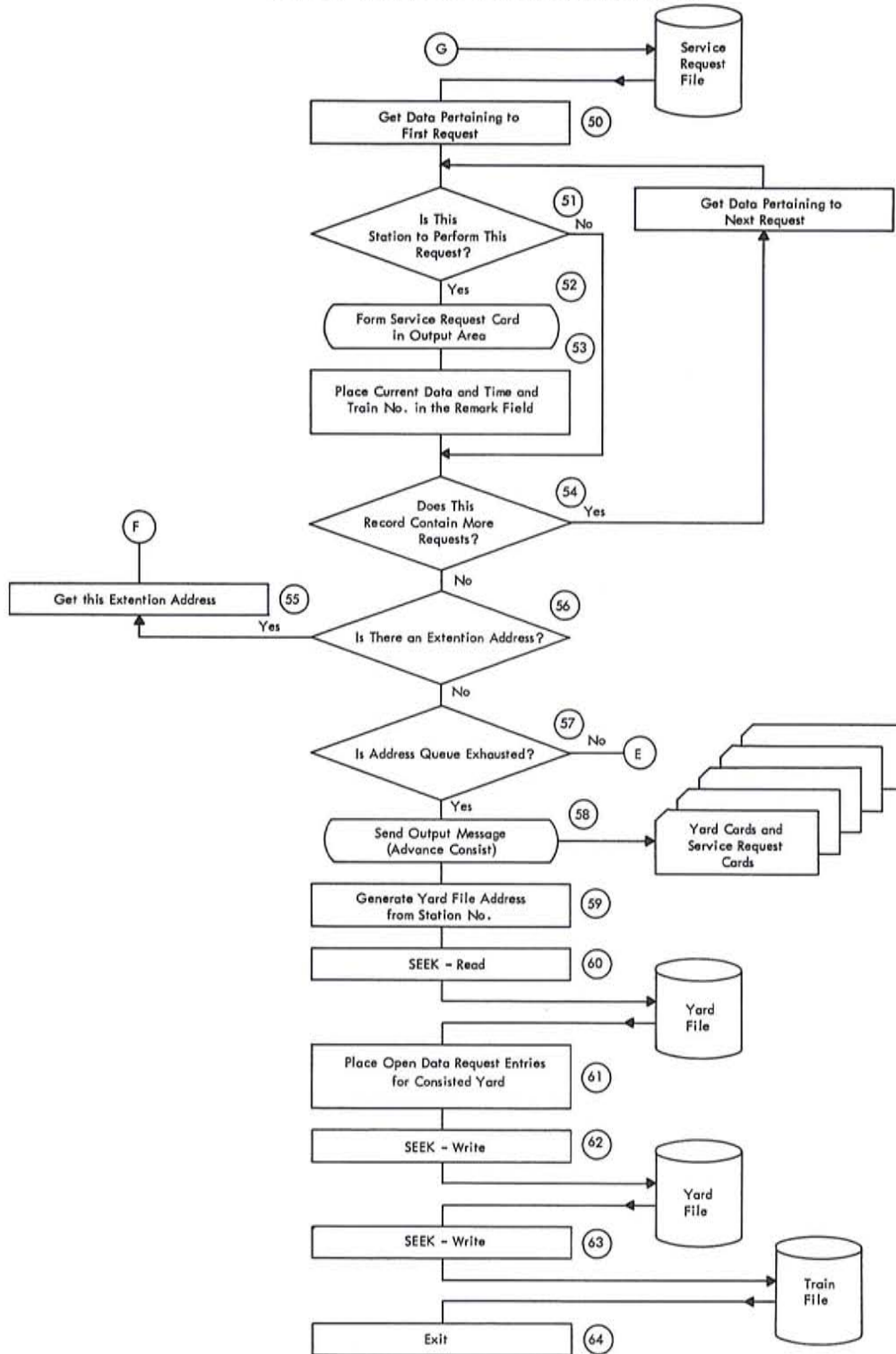

FIGURE 4-33 (CONTINUED) *Southern Pacific Company*

Block 46 - Form block card data for output.

Block cards are formed for all groups of cars for which yard card images have not been formed.

Block 47 - Place car consist in train order.

Yard card, and block card fields are placed in the output area in train order.

Blocks 48-57 - Service request cards, sent with the advance consist, are formed.

A queue of service request file addresses was built up from the car file while the consist was obtained. These addresses are now used to read selected portions of the service request file and check for service requests to be performed at the yard being advance consisted. The card fields are formed in blocks 64 and 65, and block 69 checks for completion of the process.

Block 58 The complete consist, followed by service request cards, is now in the output area and a command is given to the supervisory program to transmit the message.

Blocks 59-61 The yard file address is generated from the station number and the yard file is read into core storage.

Open data entries are placed in the first physical record of the yard record of the consisted yard as follows:

1. The train file address is placed in the subrecord area for open train-data requests.
2. The service request file address of service requests sent with the advance consist are placed in the appropriate sub-record area.

The yard file is then written back into file storage.

Blocks 62-64 The train record is written back into file. The train data request tags now show that the advance consist has been performed, and program exit is performed.

ARRIVAL TIME

General

The arrival time is punched in the data field of the arrival time data request card. Thus, the arrival time is available to update the train file, and other required operating records. This program is for thru trains.

Operations performed include:

1. Obtain the train record.
2. Replace the estimated arrival time with the actual arrival time in the train file.
3. Update car location, date, and time in car record for cars which are not in blocks and are not to be left at this yard.
4. Transfer responsibility to the yard file for cars set out at this yard, and retain a record of this transfer in the train file until train termination.
5. Update the car file responsibility address, date, time and location for cars scheduled to arrive at this yard.
6. If this is an intermediate yard, call the departure report program if all train data has been entered.
7. If this is a terminating yard, call the wheel report program if all terminating train data has been entered.

The sequence of operations in this program is chosen to expedite the handling of operating records for thru trains by assuming that car moves for blocks of cars have been made as planned. For the few cases of cars not moving in blocks, and not destined for this station the location, date, and time are updated in the car file. The car file continues to have the train file address in its responsibility file address field for all cars not destined to leave the train at this yard.

Program Description (Arrival Time)

- Blocks 1-4 The arrival time data request card is re-entered into TOPS System (Figure 4-34). The reference address is decoded, and the program and train file are read into core storage.
- Block 5 The train file data request tag is set to show that the arrival time has been received. For ease in following the flow chart, train order is assumed to be:
1. Cars not traveling in blocks and destined for other stations.
 2. Cars traveling in a block destined for this station.
 3. Cars traveling in blocks destined for a station further down the line.
- Block 6 In block 6, the fields in the train file describing each car on the train are obtained in sequence. These fields consist of:
1. The subrecord area for the car being checked, which contains a set out point and brief summary information for cars scheduled to leave the train whether these cars are traveling in a block or not.
 2. The car's subrecord area in the active portion of the train file. "Get next car's record in the train file" means looking at the train file representation of the train in consist order.

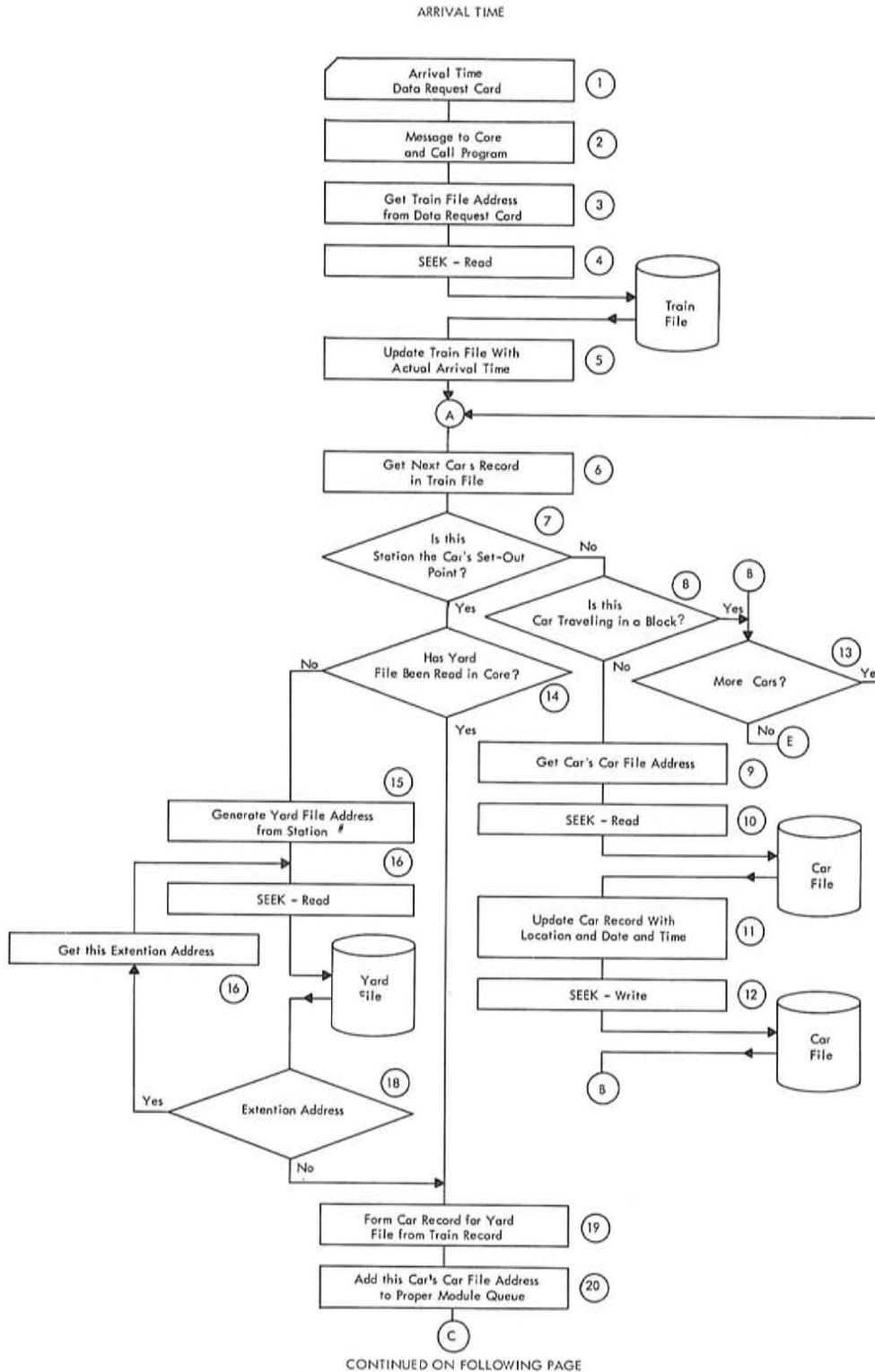

FIGURE 4-34 PROGRAM DESCRIPTION - ARRIVAL TIME

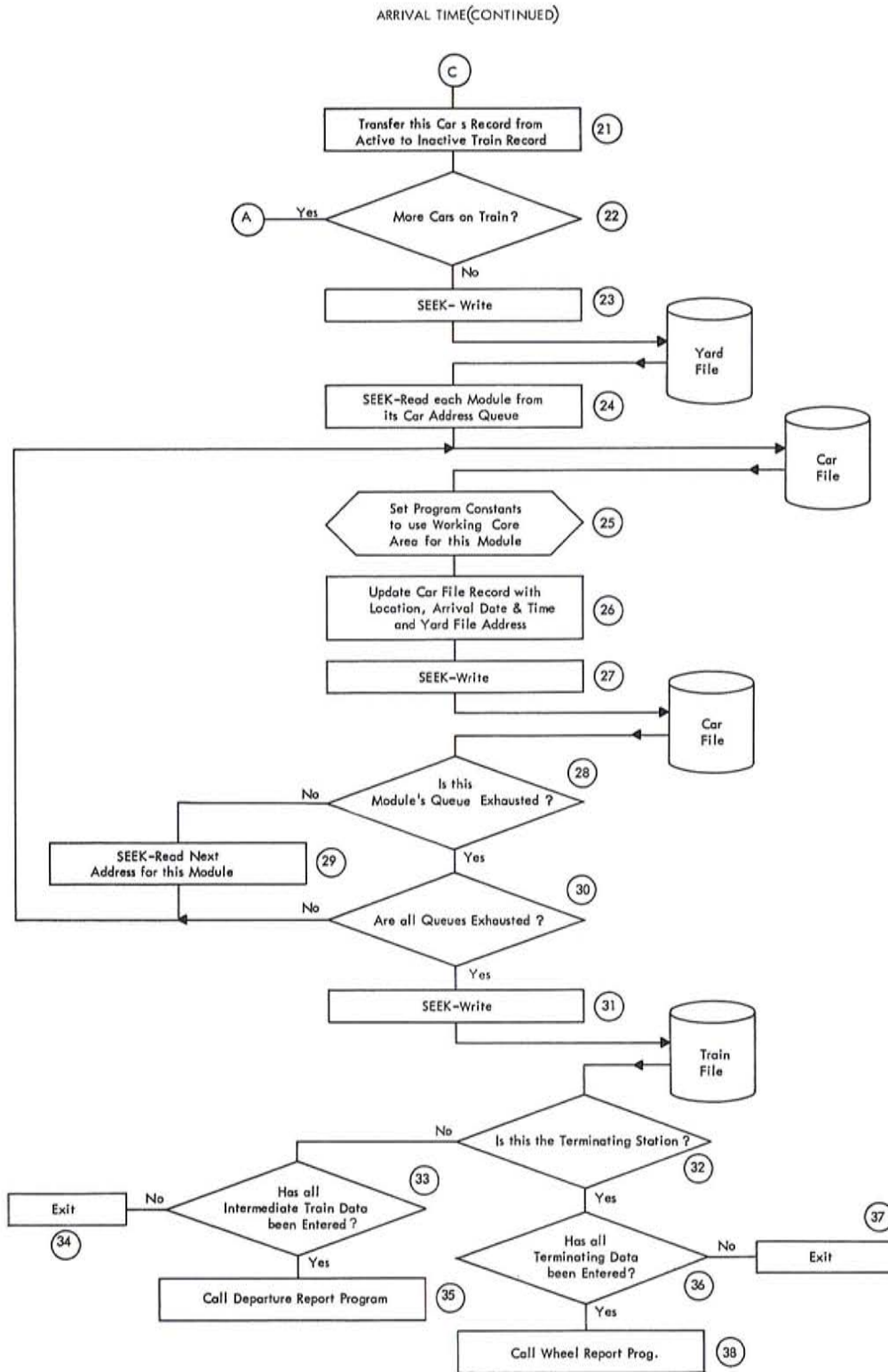

FIGURE 4-34 (CONTINUED) *Southern Pacific Company*

Blocks 7-13 (Cars not traveling in blocks destined for other station)

Cars not traveling in blocks and not destined for this yard constitute a small portion of the car volume of thru trains. The locations, dates, and times for these cases are updated in the car file.

Blocks 7 & 14-22 (Cars not traveling in a block destined for this station)

The car file address for each car destined for this station is:

1. Transferred to the yard responsibility file.
2. Transferred to the inactive portion of the train file.
3. Placed in a queue for the proper file module in preparation for the car file update; this is illustrated in blocks 23 through 30 of the flow chart.

Blocks 7, 8 & 13 (Cars traveling in blocks destined for a station further down the line)

This case occurs only at intermediate yards. No changes are made in the car file, train file, or yard file for this case. Movement of cars falling into this category is reflected in the yard file in the summary data developed when the intermediate consist program is obtains this data from the train file.

Block 23 The updated yard record is written back into file storage.

Blocks 24-30 (Car file update)

The car file is updated for all cars destined for this station. The yard responsibility file address replaces the train file address, and the date, time and location fields are updated. The control of processing and car file access is the same as that employed in the initial consist program.

Blocks 31-38

The updated train file is written. At a terminating station, the wheel report program is called if the work performed enroute, crew off duty, and locomotive assignment programs have been performed to complete the train movement. Completion of train data is determined by testing the train file data request tags.

If this is an intermediate station, a check is made to determine if all programs called by data request cards, which were sent with the advance consist, have been performed. If so, the departure report program may be incorporated in the programs which are shown as calling it.

If this is a terminating station and all data requests are fulfilled, a train performance report is generated from the train file as a part of the wheel report program.

Southern Pacific Company

Train Performance Report generation operates in the same way as Departure Report generation. The output formats are also the same, except that the message type appearing as the first line is PERF instead of DEPT. The performance report also differs in that block descriptions are not included; these are not included because blocks are not transferred from train to train, but are reformed from set-out headers followed by yard cards. The Train Performance Report describes the consist moved from the previous station. The actual arrival and departure times for all stations are also reported.

TABLE OF CONTENTS
COMMUNICATIONS ANALYSIS

| | Page |
|--|------|
| INTRODUCTION | 5-1 |
| COMMUNICATIONS FACILITIES FOR MAJOR I/O UNITS | 5-1 |
| General | 5-1 |
| Communications Requirements for On-Line Locations | 5-2 |
| Communications Requirements for Off-Line Locations | 5-2 |
| Data Transfer | 5-3 |
| Development of Line Layouts | 5-8 |
| Standby Communications Requirements | 5-9 |
| Communications Implementation Schedule | 5-10 |
| Future Facilities Testing | 5-10 |
| COMMUNICATIONS FACILITIES FOR MINOR INPUT UNITS | 5-10 |
| COMMUNICATIONS FACILITIES FOR HIGH SPEED DATA | |
| TRANSMISSION UNITS | 5-13 |
| General | 5-13 |
| Facilities Testing | 5-13 |
| COMMUNICATIONS FACILITIES FOR REMOTE LISTING I/O UNITS | 5-14 |
| LINE LAYOUT FOR MAJOR I/O UNITS | 5-16 |

LIST OF ILLUSTRATIONS

| Figure | | Page |
|--------|---------------------------------|------|
| 5-1 | Interface with I/O Units | 5-3 |
| 5-2 | Typical Line Configuration | 5-4 |
| 5-3 | Timing Diagram - Polling Mode | 5-4 |
| 5-4 | Timing Diagram - Selection Mode | 5-7 |
| 5-5 | Line Layout for Major I/O Units | 5-11 |

COMMUNICATIONS ANALYSIS

INTRODUCTION

Communications will supply the vital link for the transfer of current data between I/O units in Southern Pacific offices throughout the country and the TOPS central processor in San Francisco. It will thus provide I/O units with access to the timely and vital information in the central processor.

The Southern Pacific Communications Department will supply the facilities required for on-line locations. Off-line offices, generally, will be tied into the system via leased facilities to the nearest on-line point.

One of the prime considerations in the determination of the communications requirements was meeting the operational requirements of the system, such as the data volumes to be transmitted, their distribution in time, the means of preparation of the source information, and permissible wait times and/or response times. Another major consideration was the type of facilities that are and will be available at the time of system implementation.

Communications is not an independent entity in the TOPS System. As noted previously, it supplies the vital link for data transfer between locations. Accordingly, in the communications analysis it is also necessary to consider the various classes of equipment that will be used. It was determined that a different type of data communications capability was required for each general class of I/O unit. Thus, the four classes of communication facilities required are:

1. Communications facilities for major input-output units.
2. Communications facilities for minor input-output units.
3. Communications facilities for high speed data transmission units.
4. Communications facilities for remote listing input-output units.

COMMUNICATIONS FACILITIES FOR MAJOR INPUT-OUTPUT UNITS

General

In the TOPS System, no rehandling of data is required between the origination of a record and its ultimate processing at the central processor. The major I/O units in the system for operating and traffic information all have this direct access to the central processor. In most cases several I/O units will "share" a communications line to the central processor. This sharing will be discussed in more detail in another section of this book.

The operating, accounting, and traffic I/O units are identical insofar as the required data communications capability at on-line locations. The required off-line traffic office communications capability is somewhat different because leased facilities must be used.

The information transfer ability between major I/O units and the central processor is the "heart" of data gathering and distribution in the TOPS System. The vast majority of data transmitted in the system will be between the preceding units.

Communications Requirements For On-Line Locations

The communications channels planned for the major I/O units must be private, i. e., reserved exclusively for TOPS System use twenty-four hours a day, seven days a week. The channels must be full duplex, be capable of data transmission rates up to 180 bits/second, and be non-code restrictive. The interface between the IBM 7750 Programmed Transmission Control and major I/O units with the communications equipment is that specified in the Electronic Industries Association Recommended Standard 232, "Interconnection of Data Terminal Equipment with a Communications Channel," with certain modifications. The modifications are as follows:

- Section 1.5 The total distortion added to the signal by the communications facilities (subsets and line) should not exceed 25 per cent.
- Section 2.1.3 Signals presented on this line will be effective only if the Send Request (RS) lead is in the "ON" condition.
- Section 2.1.4 When the carrier is not detected at the demodulator, the subset will clamp this lead in the "space-hold" condition. This clamp will be removed after the carrier has been reliably detected. The clamp will be restored when the carrier is no longer being received at the demodulator.
RD?
- Section 2.1.5 The subset should have the capability of strapping the (RS) lead to a fixed voltage, such that the signal may be permanently in the "ON" condition when used with the IBM 7750 Programmed Transmission Control. Provision must be made at the subset to enable placement of the (RS) lead in an "OFF" condition under emergency conditions.
- Section 2.1.6 This circuit is not required.
- Section 2.2 Connected Circuit - The circuit shall consist of a relay contact to ground. This relay contact should be closed after the carrier has been detected at the demodulator and should be opened after loss of carrier has been detected.
Do not *X*

Communications Requirements For Off-Line Locations

As noted previously, the communications requirements for most off-line traffic offices are different since leased facilities will be required. Under present tariffs the most economical means of meeting the functional requirements for off-line traffic offices will be through the lease of full duplex channels suitable for the transmission of data at the rate of 75 bits per second. Such channels should not be code sensitive. The interface with the I/O units will be two 60 ma, neutral, dc loops. The interface is shown in Figure 5-1.

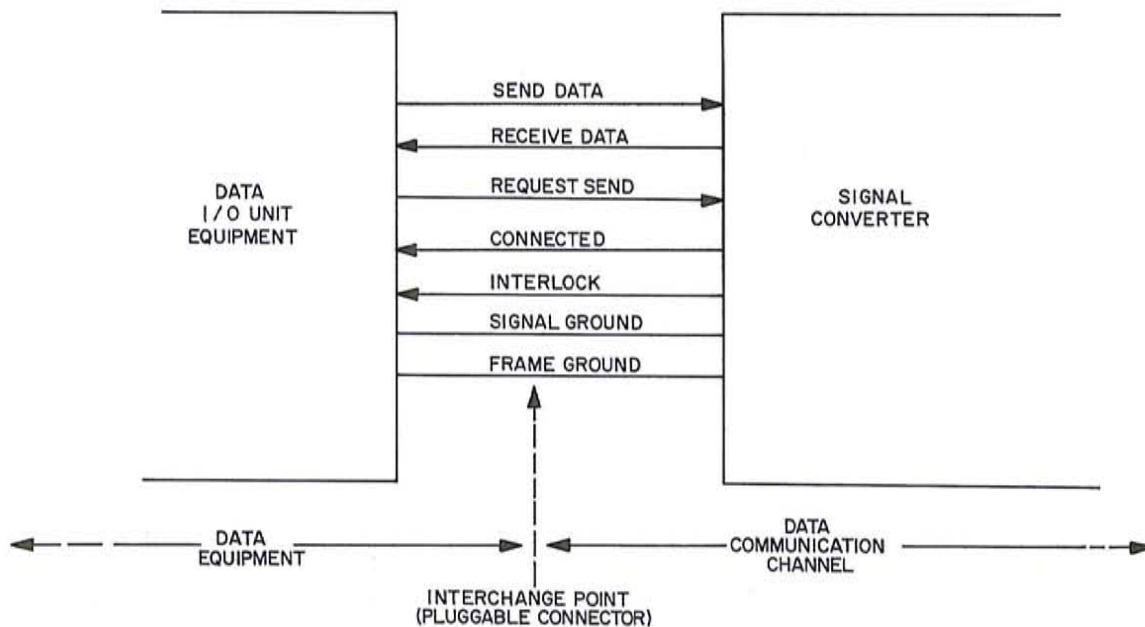

FIGURE 5-1 INTERFACE WITH THE I/O UNITS

Data Transfer

The IBM 7750 Programmed Transmission Control is used to link the central processor to the communications network. A complete description of the operational capability of the IBM 7750 is included in the Programming Analysis section of this book. That section contains a description of the polling and selection routines that will be used in the System.

Polling and selection of major I/O units will be described briefly here with emphasis being placed on what occurs at the interfaces with the communication system.

1. Polling

Figure 5-2 (Typical Line Configuration) and Figure 5-3 (Timing Diagram-Polling Mode) illustrate the following procedure. The interlock lead is normally "ON" and this lead will always be in this state under normal operating conditions (reference EIA RS-232). Assume that no information is being transmitted or received from the line. All I/O units are monitoring the line for a polling or selection sequence. The initial status of the various data and control leads are as follows:

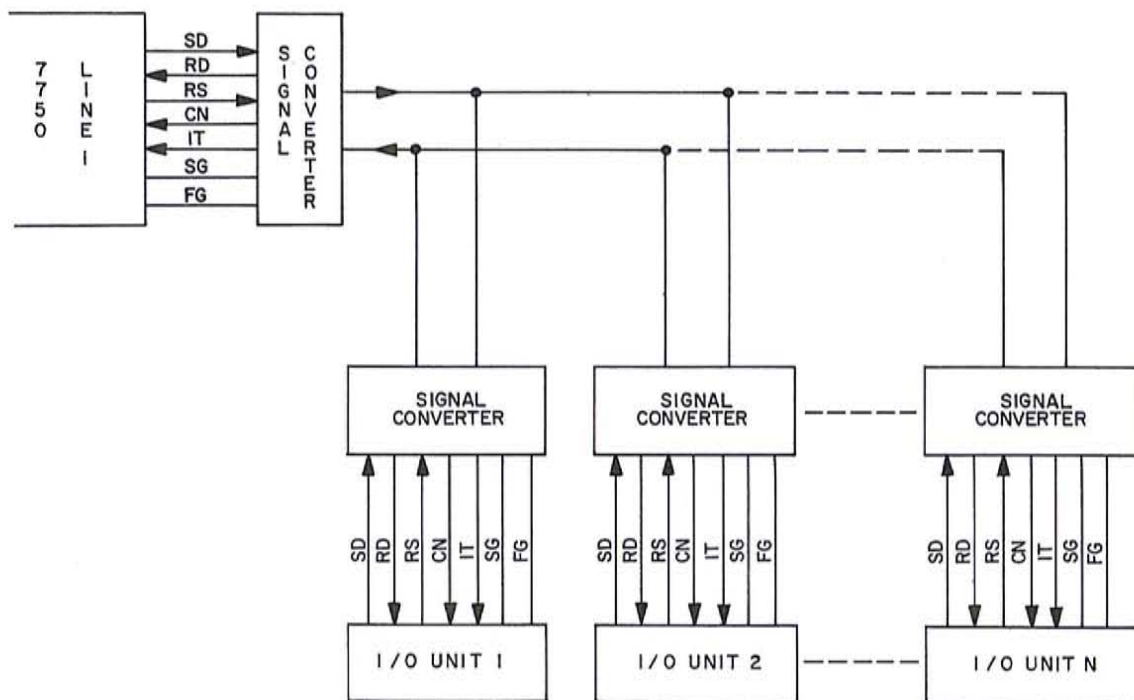

FIGURE 5-2 TYPICAL LINE CONFIGURATION

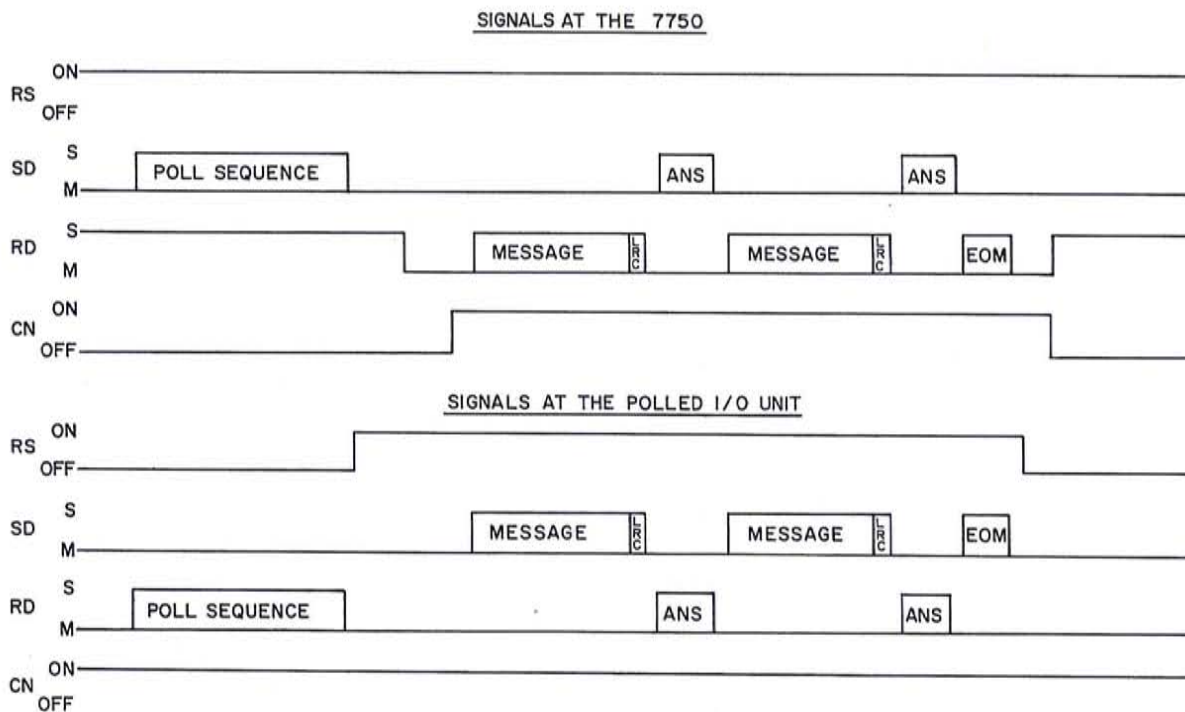

FIGURE 5-3 TIMING DIAGRAM-POLLING MODE

At the 7750

SD - mark hold
RD - space hold (clamped by subset)
RS - "ON" (strapped at subset)
CN - "OFF"

At all I/O units

SD - mark hold
RD - mark hold (Since RS lead at the 7750 is permanently "ON," the state of the SD lead is continually transmitted down line).
RS - "OFF"
CN - "ON" (continually under normal operating conditions)

The timing diagram shows that all signals appear to be sent and received effectively in synchronism. This would be true if the transmitting and receiving equipment were in close proximity, i. e. in the same building. To find the exact relative timing for any particular location, the propagation delay must be calculated and added to the appropriate delay between the received and transmitted signals.

As an example, suppose that the IBM 7750 wishes to poll an input component of I/O unit #2. The IBM 7750 will transmit a polling message. This message will be recognized by I/O unit #3 and it will change the state of its RS lead from "OFF" to "ON." At this time the SD lead is in the mark hold state. The subset at the IBM 7750 will receive the frequency corresponding to MARK almost immediately (ignoring the propagation delay). At this time the RD lead at the IBM 7750 is being clamped to a space hold condition.

The clamp is maintained until it is fairly certain that the signal being received from the line is valid and is not, in all probability, just a noise burst. At this time, the clamp on the RD lead will be removed and RD will be changed to a mark hold condition. After the carrier has been received at the IBM 7750 subset for a pre-determined interval, the CN lead will change from "OFF" to "ON."

Summarizing the states of the signals:

At the IBM 7750

SD - mark hold
RD - mark hold
RS - "ON"
CN - "ON"

At I/O unit #2

SD - mark hold
RD - mark hold
RS - "ON"
CN - "ON"

When no information is being exchanged between the IBM 7750 and unit #2 (after it has been polled) all signals will remain in the above quiescent state.

Southern Pacific Company

I/O unit #2 is now ready to respond to the polling inquiry. Two responses are possible: message present or no message present. The I/O unit will check to see if the addressed component has a message waiting for transmission. If it has, the I/O unit will respond by transmitting the first character of the message. If the polled component has no information to transmit, the I/O unit will respond with a single character and will "disconnect" itself from the line (on the transmit side). In either case, the I/O unit will wait a predetermined time after changing its RS lead from "OFF" to "ON" before transmitting a response. This allows sufficient time for all control and data leads to be in their quiescent state before a response is generated. The sequence of events in "disconnecting" after a "no message" response is identical to the sequence occurring after the transmission of an end of message character. This sequence is discussed in detail in a succeeding section.

A longitudinal redundancy check (LRC) character is sent at the end of every block of characters transmitted from the I/O unit. A complete block will consist of one typing line or IBM card. After the LRC has been transmitted, all signals are in the previously mentioned quiescent state. If the LRC transmitted from the I/O unit agrees with the internally generated LRC character of the IBM 7750, the IBM 7750 will respond with a character that will enable the I/O unit to transmit the next block of characters. If there is an LRC non-compare, the IBM 7750 will transmit a character indicating to the I/O unit that the information transmitted was invalid in part and that a retransmission is necessary. In either case, sufficient delay will be generated to allow the I/O unit to receive the character transmitted from the IBM 7750 (operationally, the I/O unit, like the IBM 7750, operates only in a half duplex mode).

The transmitting component will retransmit the last block of characters if LRC non-compare occurred. The information will be sent three times only (two retransmissions). At this time, an error signal will be sent to the I/O unit which will alert the operator to the difficulty.

If the LRC was correct, the I/O unit will continue with the message until completion. If the final block of the message is correct, an end of message character will be transmitted from the I/O unit. After transmission of this character, the I/O unit will disconnect itself from the line. The RS lead at the I/O unit will be changed from "ON" to "OFF"; this turns off the carrier on the line. Ignoring the propagation delay, the loss of carrier will be detected by the subset at the IBM 7750. After a short period (to ignore the effect of a short loss of transmission due to noise) the clamp will be restored on the RD lead at the IBM 7750 and the CN lead will be changed to "OFF."

The signals are now in their initial states in which all I/O units are monitoring the line and waiting to be polled or selected.

2. Selection

Figure 5-4 (Timing Diagram-Selection Mode) illustrates the selection sequence. Assume I/O unit #2 is to be selected. The appropriate selection sequence of characters will be transmitted from the IBM 7750. The I/O unit will recognize its address and will respond as follows: The RS lead will be changed from "OFF" to "ON"; after a short delay the clamp on the RD lead at the IBM 7750 will be removed, allowing it to go into the mark hold state; after the carrier has been detected on the line for a predetermined interval, the CN lead changes from "OFF" to "ON"; at this point, the I/O unit is ready to answer back.

Southern Pacific Company

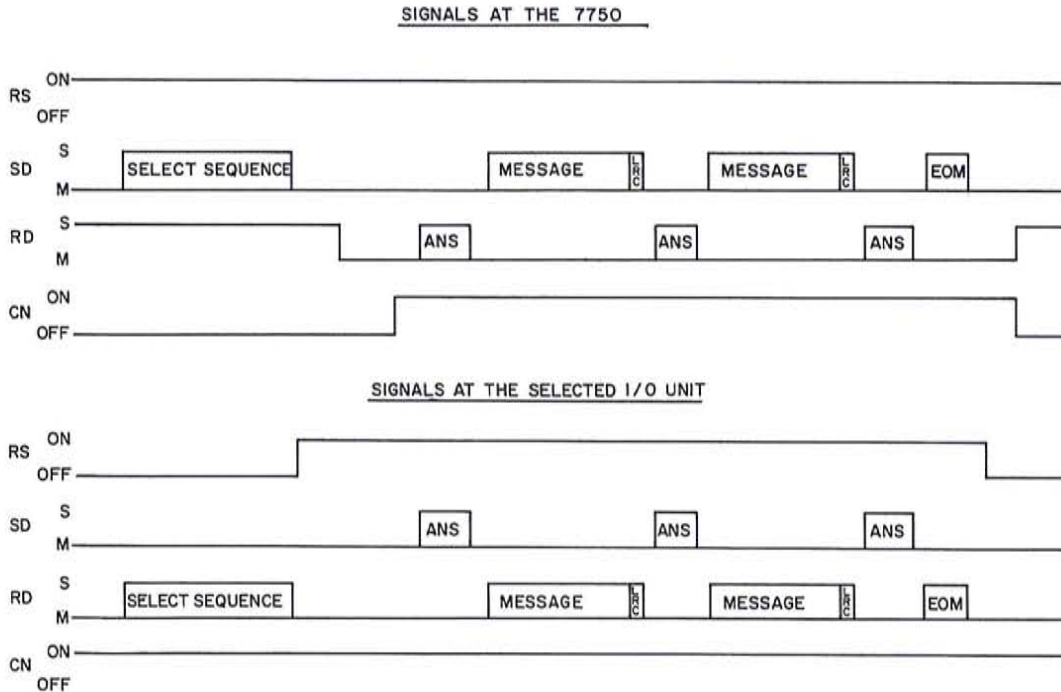

FIGURE 5-4 TIMING DIAGRAM-SELECTION MODE

The answer-back in the selection case is different from that in the polling case. In polling, the answer-back signifies either message present or no message present. In this case, the answer-back signifies that the I/O unit and component(s) are available and ready to receive information or that they are unavailable.

Since certain components of the I/O unit may be used under local control rather than under control of the IBM 7750, it is possible that the addressed component is unavailable. If the component address signifies more than one component is being selected, the I/O unit will check the required combination of components before an answer-back is sent. The answer-back will consist of a single specific character if the addressed component(s) is not available. In such a case, the I/O unit will disconnect after an end of message character in the polling sequence. If the component(s) is available, the answer-back will be the I/O unit address and component(s) address. These two characters are available to the program so that a positive response may be noted. In this case the I/O unit, after appropriate turn-around time, is ready to receive the message from the IBM 7750.

The message will be transmitted in blocks of one typewritten line or one IBM card. The last character of the block will always be LRC. The LRC will be noted by the I/O unit and compared with its internally generated check character. If the comparison is correct, a single character will be transmitted to the IBM 7750 and the I/O unit will prepare to receive the remainder of the message. If the comparison is incorrect, the I/O unit will respond with a single character that will cause the IBM 7750 to retransmit the information twice; if an error still exists, the operator will be alerted. Assuming that the LRC checks are correct, message flow will continue from

the IBM 7750. When the end of message is recognized at the I/O unit, the RS lead changes from "ON" to "OFF." After the loss of carrier is detected at the IBM 7750 subset, the RD lead is clamped to space hold and the CN lead is changed from "ON" to "OFF." The signals are now identical to the initial case in which all I/O units are monitoring the line and waiting to be selected or polled.

3. Error Detection

Periodic error checking is essential in the transmission of large volumes of data over any communications system. This checking avoids lengthy retransmission on error detection. In operating units, checking will occur after each IBM card has been transmitted. In the case of accounting and traffic terminals, each line of the message will be considered a block and will be checked.

The objective in setting periodic checks in a message and establishing error routines is to maximize throughput of the communications system. The decision as to the frequency of checking and the type of error detection to be used is based on the results of facility tests conducted to date.

Development of Line Layouts

One of the major products of the communications analysis is the line layouts for the major I/O units; that is, the determination as to which I/O units or combination of units should be placed on a given communication line and still meet the functional objectives of the System. The design criteria used in the development of these line layouts are as follows:

1. Ninety percent of all operating messages originated over a twenty-four hour period will have a wait time of less than fifteen minutes. In this case, wait time is defined as the time when a complete message is ready for transmission until the time the first character is sent to the central processor.
2. Ninety percent of all input messages from a dispatcher I/O unit will have a wait time of less than two minutes.
3. Eighty percent of all car tracing and manifest requests from traffic type I/O units will have a virtually immediate response. Response time is measured between the time a tracing message is ready for transmission until the first character of the reply is printed out at the I/O unit. It is assumed that an input tracing or manifest message will be approximately fifteen characters in length.

Generally, the freight traffic I/O units and dispatcher I/O units were placed on lines not having operating units. This was done in order to ensure rapid tracing and manifest response times and low wait times for dispatcher entries. There are two dispatcher I/O units for virtually every Southern Pacific dispatcher location. In all cases, standby I/O units have been placed on separate lines so that they are operationally independent. In certain cases standby I/O units have been placed on lines with one or more operating I/O units; therefore, they may not provide the two minutes response. therefore, they may not provide the two minutes response. With one exception, the

With one exception, the number of major I/O units of all types placed on a line has been limited to five. Actually, the large majority of lines service only one, two, or three units.

A number of line simulations using an IBM 7090 computer were made. A description of the results of these simulations is included in the section on System Analysis. These simulations provided the necessary usage guide in the determination of which I/O units were to be placed together on a line and still meet the design specified criteria. The major I/O unit line layout is shown in the foldout, Figure 5-5. A complete list of the I/O unit locations and the communications lines that will service them is given at the end of this section.

Priorities established for message handling in the major I/O units are described in the discussion of the IBM 7750 Programmed Transmission Control in the Program Analysis section.

Standby Communications Requirements

TOPS will be a central system. That is, under normal operating conditions all data from the major I/O units will be sent to the central processor, and all data will be received from the central processor. From time to time communications failures may occur in certain areas. During such times it may be necessary to have the capability to connect two operating I/O units directly together at two separate major yards. This will enable the transmission of vital train movement information on a point-to-point basis during the communications failure. A listing of the locations between which this capability is considered desirable is included below.

- Avondale - Lafayette
- Lafayette - Alexandria, Lake Charles, Beaumont
- Beaumont - Englewood
- Englewood - San Antonio, Hearne, Lufkin
- San Antonio - El Paso, Alice, Corpus Christi, Edinburg
- Hearne - Corsicana, Ennis
- Ennis - Fort Worth
- El Paso - Tucson
- Yuma - Tucson, El Centro, Indio
- Indio - Colton
- Colton - Los Angeles
- Los Angeles - Los Nietos, Bakersfield, Santa Barbara
- Bakersfield - Fresno
- Fresno - Roseville, Stockton, Tracy
- Tracy - Stockton, Roseville
- Roseville - Oakland, San Jose, Sparks, Dunsmuir
- Sparks - Ogden
- Dunsmuir - Klamath Falls, Ashland
- Oakland - San Jose, Bayshore, Tracy
- Eugene - Portland, Klamath Falls, Ashland

If more than two locations on the list are shown on the same line, then the requirement is to be able to communicate directly between the first yard listed and each of the other yards at different times. For example, referring to the yards indicated

Southern Pacific Company

on the fourth line of the list, it is necessary to be able to transmit data directly between Englewood and San Antonio, and between Englewood and Hearne, and between Englewood and Lufkin at different times during a communications failure affecting these locations.

Communications Implementation Schedule

The schedule for system installation is included in the Implementation and Installation section of this book. The dates at which communications facilities should be available coincide with the cut-over dates for the I/O units. These dates are given below:

- | | |
|--|-----------------|
| 1. All Pacific Lines accounting and on-line traffic I/O units. | July 1, 1964 |
| 2. Operating units in the Portland, Shasta, Sacramento and Salt Lake Divisions. | July 1, 1964 |
| 3. Operating units in the Coast, Western, San Joaquin and Los Angeles Divisions. | January 1, 1965 |
| 4. Off-line traffic office I/O units. | January 1, 1965 |
| 5. All Pacific Lines minor input units. | January 1, 1965 |
| 6. Operating units in the Tucson and Rio Grande Divisions. | July 1, 1965 |
| 7. Pacific Electric accounting I/O units. | July 1, 1965 |
| 8. All Texas and Louisiana Lines I/O units (including minors). | January 1, 1966 |
| 9. All NWP and SD & AD I/O units. | July 1, 1966 |

Future Facilities Testing

As previously indicated, the majority of data will be transferred between major I/O units and the central processor. It is essential that this data be correct. To insure this, it is necessary to have adequate error detection provisions. IBM is prepared to conduct future facilities testing, in conjunction with the Southern Pacific Communications Department to verify that the most efficient error detection arrangement and the optimum block lengths for data transmission are being used in the new facilities.

COMMUNICATIONS FACILITIES FOR MINOR INPUT UNITS

The minor input-only units consist of the IBM 1001 Data Transmission System and receiving IBM 26 Card Punches with data translators. The IBM 1001 Data Transmission System will utilize the Southern Pacific dial network. All minor input locations on Pacific Lines will dial a San Francisco extension and transmit their data; the data will be punched into a series of cards in San Francisco. Similarly, all minor input units on the Texas and Louisiana Lines will dial into Houston. The required number of

Southern Pacific Company

FIGURE 5-5 LINE LAYOUT FOR MAJOR I/O UNITS

lines on rotary groups in San Francisco and Houston will be seven and three, respectively. Cards punched at these two locations will be transferred to a card reader on a major I/O unit for subsequent entry to the TOPS central processor.

The IBM 1001 Data Transmission System is designed to operate in conjunction with a dial telephone system. The input in this network will operate with communications equipment having an interface and data transmission capability similar to the Data Phone 401A (transmitter) and Data Phone 401B (receiver).

Two series of tests with the IBM 1001 were performed by sending from various locations in the Portland, Western, San Joaquin and Los Angeles Divisions into San Francisco.

These tests revealed that data collection in San Francisco for Pacific Lines minor input units is technically feasible. Difficulties were encountered in some locations, but errors in data transmission were detected at both the transmitting and receiving units. It was determined that this type of data transmission over the voice portion of channels that use speech-plus circuits is possible. It was also found that the lifting of a handset on the same circuit as the IBM 1001 will result in an error(s) if data were being transmitted from the input set at that time. Thus, it is advisable to severely limit the number of extensions and other parties on the same circuit with the IBM 1001.

COMMUNICATIONS FACILITIES FOR HIGH SPEED DATA TRANSMISSION UNITS

General

There is a requirement for high speed data transmission at 1200 bits per second between San Francisco and Houston, and Los Angeles and Portland. This data transmission capability will be used to transfer freight bills and car distributor reports to the above locations three times a day.

The equipment that will be used for this application must operate with communications equipment that conforms to the Electronic Industries Association Recommended Standard 232 "Interconnection of Data Terminal Equipment with a Communications Channel."

Data transmission at 1200 bits per second will take place between San Francisco and only one of the other three locations at any one time. The information will be physically transferred from the TOPS central processor in the form of a magnetic tape to an IBM 7702 Magnetic Tape Transmission Unit. A full duplex voice channel will be maintained to the appropriate city and the freight bill and car distributor data will be transferred directly from the IBM 7702 to an IBM 1009 Data Transmission Unit attached to an IBM 1401 central processor. This operation is independent of the central processor in San Francisco.

Facilities Testing

Tests covering a period of approximately two months were conducted between San Francisco and Houston, and Los Angeles and Portland. Data was transmitted

Southern Pacific Company

at 600 and 1200 bits per second. A full report on these tests has been forwarded to the Communications Department.

In summary, it was determined that transmission at 600 and 1200 bits per second was technically feasible and that a 1200 bits per second rate would be the most efficient. Under normal operating conditions, it was found that the anticipated volume of information could be successfully transferred. The actual error rates encountered varied considerably. For example, during a Portland test, thirteen consecutive hours of error free transmission occurred (over 56 million bits, or 7 million characters, were sent without one error). At other times considerable interference took place and data could not be transmitted. Such times nearly always coincide with bad weather conditions. The latter difficulty can be expected to occur, in varying degrees, in all open wire communications systems. Southern Pacific's present program of microwave installation will result in a considerable improvement in communications reliability and will also result in a decreased error rate.

COMMUNICATIONS FACILITIES FOR REMOTE LISTING INPUT-OUTPUT UNITS

The "remote listing" IBM 1912 Telegraphic Card Reader-Punch Units are used to transfer information on a point-to-point basis within a major yard complex. A full description of the I/O unit to be used for this purpose is included in the Equipment Specifications section of this book.

The communications requirement of the IBM 1912 is a standard half-duplex telegraph dc loop. The IBM 1912 can be made available to operate at either 60, 75, or 100 words per minute, using the 7.42 bit per character Baudot Code in transmission (conversion from the IBM Card Code to the transmitted Baudot Code, and vice versa, is an internal function of the IBM 1912).

The "remote listing" locations and lines are:

| IBM 1912 | TELEGRAPH EQUIPMENT |
|-----------------------------------|------------------------------|
| Eugene Yard Office | Eugene West End |
| Eugene Yard Office | Eugene East End |
| Roseville Hump (1) | Retarder Towers for Hump (1) |
| Roseville Hump (2) | Retarder Towers for Hump (2) |
| San Jose | San Jose West End |
| Tucson 22nd St. - Tucson 38th St. | Tucson Yardmaster (1) |
| Yuma Yard | Yuma Subway - Yuma Point (2) |
| Los Angeles Hump | Los Angeles Hump |
| Los Angeles Bull Ring | Los Angeles Bull Ring |
| Los Angeles "C" Yard | Los Angeles "C" Yard |
| Bakersfield Yard Office | Bakersfield Edison |
| Fresno Yard | Fresno Merced Street |
| Houston - Englewood Yard Office | Houston - Englewood Bowl |
| Houston - Englewood Yard Office | Houston - Englewood Hump |

(1) Tucson - 22nd St. transmits to 36th St. and the Yardmaster on a multi-point line. The equipment at 22nd St. and 36th St. consists of an IBM 1912; telegraph equipment is required at the Yardmaster's location.

Southern Pacific Company

(2) Yuma Yard transmits to Yuma Subway and Yuma Point on a multi-point line. The equipment at the yard consists of an IBM 1912; telegraph equipment is required at Yuma Subway and Yuma Point.

LINE LAYOUT FOR MAJOR I/O UNITS

The following listing shows the major I/O unit locations and the communications lines that will service each location. Where more than one (x) is shown for a specific I/O unit in a given location, this indicates that there is more than one such unit at that location. This listing may be used as a reference to the foldout, Figure 5-5.

LINE LAYOUT FOR MAJOR I/O UNITS

| LOCATION | TYPE OF I/O UNITS | | | | LINE NUMBER |
|--|-------------------|------------|------------------------|---------|-------------|
| | Operating | Accounting | Operating & Accounting | Traffic | |
| PORTLAND DIVISION | | | | | |
| Brooklyn SE | x | | | | 1 |
| Brooklyn SE | x | x | | | 2 |
| Brooklyn NE | x | | | | 3 |
| NPT Interchange | x | | | | |
| Salem | x | | | | |
| Portland Car Distb. | | | | xx | 4 |
| Portland Freight Traffic | | | | x | |
| Seattle Freight Traffic | | | | x | |
| Albany | x | | | | 5 |
| Coos Bay | x | | | | |
| Springfield | x | | | | |
| Eugene Dispatcher | | | | x | 6 |
| Salem Freight Traffic | | | | x | |
| Eugene Dispatcher | | | | x | 7 |
| Eugene Freight Traffic | | | | x | |
| Eugene Yard Office | x | | | | 8 |
| Eugene Yard Office | x | x | | | 9 |
| Eugene Yard Office | | x | | | 10 |
| Eugene Old Yard | x | | | | |
| Roseburg | x | | | | 11 |
| Grants Pass | x | | | | |
| Medford | | | x | x | 12 |
| Ashland (Shasta Division) | x | | | | |
| SHASTA DIVISION | | | | | |
| Alturas | x | | | | 13 |
| Klamath Falls | xx | x | | | |
| Dunsmuir | x | | | | 14 |
| Gerber | | | x | | |
| Dunsmuir Dispatcher | | | | x | 15 |
| Klamath Falls Traffic | | | | x | |
| Dunsmuir Dispatcher | | | | x | 16 |
| Sacramento Dispatcher (Sacramento Division) | | | | x | |

| LOCATION | TYPE OF I/O UNITS | | | | LINE NUMBER |
|--|-------------------|------------|------------------------|---------|-------------|
| | Operating | Accounting | Operating & Accounting | Traffic | |
| SACRAMENTO DIVISION | | | | | |
| Sacramento Dispatcher | | | | x | 17 |
| Sacramento Traffic | | | | x | |
| Stockton Freight Traffic | | | | x | |
| Stockton Agency (Western Division) | | x | | | |
| Sacramento Yard Office | x | x | | | 18 |
| Roseville Hump | x | | | | 19 |
| Roseville Hump | x | | | | 20 |
| Roseville Yard Office | x | x | | | 21 |
| Roseville East End | x | | | | 22 |
| Roseville PFE | x | | | | |
| SALT LAKE DIVISION | | | | | |
| Ogden Yard Office | x | x | | | 23 |
| Ogden Yard Office Carlin | x | x | | | 24 |
| Salt Lake City Freight Traffic (Off-Line) | | | | x | 25 |
| Ogden Dispatcher | | | | x | |
| Reno | | x | | x | |
| Ogden Dispatcher Fernley | x | | | x | 26 |
| Sparks | x | | | | |
| WESTERN DIVISION | | | | | |
| Oakland Yard Office | x | xx | | | 27 |
| Oakland Dispatcher | | | | x | |
| Oakland Dispatcher | | | | x | 28 |
| Oakland Freight Traffic | | | | x | |
| Oakland Homestead | x | | | | 29 |
| West Oakland Tower | x | | | | 30 |
| East Oakland | x | | | | 31 |
| Chevrolet | x | | | | |

Southern Pacific Company

| LOCATION | TYPE OF I/O UNITS | | | | LINE NUMBER |
|---|-------------------|------------|------------------------|---------|-------------|
| | Operating | Accounting | Operating & Accounting | Traffic | |
| San Francisco Disp. Train Service Bureau | | | | x | 45 |
| Train Service Bureau | | | | x | 46 |
| Regional Card Distb. System Car Distributor Rating & Revising Bureau | | | | x | 47 |
| Regional Card Distb. System Car Distributor | | | | x | 48 |
| Minor Inputs | x | | | | 49 |
| Minor Inputs | x | | | | 50 |
| Administrative Messages | | | | x | 51 |
| Data Central (Computer Center) | x | | | | 52 |
| Guadalupe is on line number 71 with three locations in the Los Angeles Division | | | | | |
| SAN JOAQUIN DIVISION | | | | | |
| Bakersfield | | | | x | 53 |
| Bakersfield Bakersfield Dispatcher Mojave | | | | x | 54 |
| Fresno | x | x | | | 55 |
| Fresno | x | x | | | 56 |
| Bakersfield Dispatcher Bakersfield Traffic Fresno Freight Traffic | | | | x | 57 |
| LOS ANGELES DIVISION | | | | | |
| Los Angeles Dispatcher Wilmington | | | | x | 58 |
| Los Angeles Harbor Tweedy | | | | x | |

Southern Pacific Company

| LOCATION | TYPE OF I/O UNITS | | | | LINE NUMBER |
|-----------------------|-------------------|------------|------------------------|---------|-------------|
| | Operating | Accounting | Operating & Accounting | Traffic | |
| Richmond Transfer | x | | | | 32 |
| Emeryville | x | | | | |
| Desert | x | | | | 33 |
| Elmhurst | x | | | | |
| Lodi | x | | | | 34 |
| Stockton | x | | | | |
| Modesto | x | | | | |
| Tracy | | x | xx | | 35 |
| Lombard | x | | | | 36 |
| Martinez | x | | | | |
| Port Chicago | x | | | | |
| Niles | | | x | | |
| NORTHWESTERN DIVISION | | | | | |
| San Rafael Dispatcher | | | | x | 37 |
| Eureka | | | x | x | |
| Santa Rosa | | x | | | |
| Eureka | | | x | | 38 |
| Willits | xx | | | | |
| Schellville | | | x | | |
| COAST DIVISION | | | | | |
| San Jose | | | x | | 39 |
| San Jose | | | x | x | 40 |
| San Luis Obispo | x | | | | |
| Watsonville Junction | x | x | | | 41 |
| Salinas | x | | | | |
| Watsonville Junction | x | xx | | | 42 |
| Salinas | x | | | | |
| Mission Bay | x | | | | 43 |
| Bayshore | xx | | | | |
| South City | x | | | | |
| San Francisco Disp. | | | | x | 44 |
| San Francisco Traffic | | x | | x | |
| Diversion Bureau | | | | x | |

| LOCATION | TYPE OF I/O UNITS | | | | LINE NUMBER |
|---|-------------------|------------|------------------------|---------|-------------|
| | Operating | Accounting | Operating & Accounting | Traffic | |
| City of Industry | xx | | | | 59 |
| Los Angeles Bull Ring | x | | | | |
| Los Angeles "C" Yard | x | | | | 60 |
| Los Angeles Hump | x | | | | 61 |
| Los Angeles Yard Office | x | x | | | 62 |
| Los Angeles Yard Office ATSF | x | x | | | 63 |
| UP | x | | | | |
| Los Angeles PFE | x | | | | |
| Los Angeles General Shops | x | | | | |
| Los Angeles Junction RR | x | | | | |
| Los Angeles Desk Yardmaster | xx | | | | |
| Los Angeles Car Distb. | | | | x | 64 |
| Los Angeles Train Service Bureau | | | | x | |
| Los Angeles Car Distb. | | | | x | 65 |
| Los Angeles Train Service Bureau | | | | x | |
| Los Angeles Pacific Elec. (Pacific Electric Div.) | | x | | | |
| Yuma Yard | x | x | | | 66 |
| Yuma Yard | x | | | | 67 |
| Indio | | | x | | |
| El Centro | xx | xx | | | 68 |
| San Diego (SD & AF Div.) | x | | | | |
| Colton | | | xx | | 69 |
| Kaiser | x | | | | |
| Guadalupe (Coast Div.) | | | x | | 70 |
| Santa Barbara | x | | | | |
| Oxnard | x | x | | | |
| Gemco | xx | | | | |
| Riverside | | | | x | 71 |
| Los Angeles Dispatcher | | | | x | |

| LOCATION | TYPE OF I/O UNITS | | | | LINE NUMBER |
|-------------------------|-------------------|------------|------------------------|---------|-------------|
| | Operating | Accounting | Operating & Accounting | Traffic | |
| PACIFIC ELECTRIC | | | | | |
| Butte | x | | | | 72 |
| Graham | x | | | | 73 |
| Long Beach | | | x | | |
| Los Nietos | x | x | | | |
| Watson | x | | | | |
| Eighth Street | x | | | | 74 |
| Baldwin Park | x | | | | |
| El Segundo | x | | | | |
| PE Dispatcher | | | | x | 75 |
| TUCSON DIVISION | | | | | |
| Phoenix | x | x | | | 76 |
| Phoenix Freight Traffic | | | | x | 77 |
| Tucson Dispatcher | | | | x | |
| Tucson Dispatcher | | | | x | 78 |
| Tucson Traffic Office | | | | x | |
| El Paso Traffic Office | | | | x | |
| Tucson PFE | x | | | | 79 |
| Tucson 22nd Street | xx | x | | | |
| RIO GRANDE DIVISION | | | | | |
| Deming | x | | | | 80 |
| El Paso Adair | x | x | | | |
| El Paso Dallas Street | | | x | | |
| El Paso Dallas Street | | | x | | 81 |
| Douglas | | x | | | |
| Lordsburg | x | | | | 82 |
| Tucumcari | x | x | | | |
| Douglas | x | | | | |

| LOCATION | TYPE OF I/O UNITS | | | | LINE NUMBER |
|--|-------------------|------------|------------------------|---------|-------------|
| | Operating | Accounting | Operating & Accounting | Traffic | |
| SAN ANTONIO DIVISION | | | | | |
| Eagle Pass | | | x | | 83 |
| Del Rio | x | | | | |
| Valentine | x | | | | |
| San Antonio Traffic | | | | x | |
| Brownsville | x | | | | 84 |
| Harlingen | | | | x | |
| Edinburg | | | x | | |
| Alice | x | | | | |
| Victoria (Houston Div.) | | | x | | |
| Gregory | x | | | | 85 |
| Corpus Christi | x | x | | x | |
| San Antonio | | | xx | | 86 |
| LAFAYETTE & HOUSTON DIVISIONS | | | | | |
| Glidden | | | x | | 87 |
| Eagle Lake | | | x | | |
| Galveston | x | | | | 88 |
| Beaumont | xx | x | | | |
| Avondale | xx | x | | | 89 |
| New Iberia | | | x | | 90 |
| Lafayette | x | | x | | |
| Alexandria | x | | | | |
| Lake Charles | x | | x | | 91 |
| Schriever | | | x | | |
| Lake Charles Traffic | | | | x | 92 |
| Beaumont Traffic | | | | x | |
| Houston Dispatcher | | | | x | |
| Houston Agency | | x | | | |

| LOCATION | TYPE OF I/O UNITS | | | | LINE NUMBER |
|--|-------------------|------------|------------------------|---------|-------------|
| | Operating | Accounting | Operating & Accounting | Traffic | |
| DALLAS - AUSTIN & HOUSTON DIVISIONS | | | | | |
| Dennison | x | | | | 93 |
| Sherman | x | | | | |
| Fort Worth | | | x | | |
| Waco | x | | | | |
| Ennis | x | | x | | |
| Miller Dallas | x | | x | | 94 |
| Dallas Yard | x | | | | |
| Corsicana | | | x | | |
| Hearne | x | | x | | 95 |
| Austin | x | x | | | |
| Dallas Freight Traffic | | | | x | 96 |
| Houston Freight Traffic | | | | x | |
| Houston Car Service Bureau | | | | x | |
| Houston Car Distb. | | | | xx | |
| Houston Dispatcher | | | | x | |
| Houston Dispatcher | | | | x | 97 |
| HOUSTON DIVISION | | | | | |
| Shreveport | | | xx | | 98 |
| Lufkin | | | x | | |
| Chaney | x | | | | |
| Englewood Yard Office | x | x | | | 99 |
| Englewood Yard Office | x | | | | 100 |
| West End | x | | | | 101 |
| Navigation Yard | x | | | | 102 |
| Minor Inputs | x | | | | 103 |
| OFF-LINE TRAFFIC OFFICES | | | | | |
| Denver | | | | x | 104 |
| New Orleans | | | | x | |
| Atlanta | | | | x | 105 |
| Birmingham | | | | x | |
| Memphis | | | | x | |

| LOCATION | TYPE OF I/O UNITS | | | | LINE NUMBER |
|---------------|-------------------|------------|------------------------|---------|-------------|
| | Operating | Accounting | Operating & Accounting | Traffic | |
| Tulsa | | | | x | 106 |
| Kansas City | | | | x | |
| Indianapolis | | | | x | |
| Washington | | | | x | 107 |
| Pittsburgh | | | | x | |
| Winston-Salem | | | | x | |
| Chicago | | | | x | 108 |
| Cincinnati | | | | x | |
| Buffalo | | | | x | 109 |
| Detroit | | | | x | |
| Cleveland | | | | x | |
| Minneapolis | | | | x | 110 |
| Milwaukee | | | | x | |
| Chicago | | | | x | |
| St. Louis | | | | x | |
| Boston | | | | x | 111 |
| New York | | | | x | |
| Philadelphia | | | | x | |

TABLE OF CONTENTS
SYSTEM ANALYSIS

| | Page |
|---|------|
| INTRODUCTION | 6-1 |
| GENERAL STUDIES | 6-2 |
| Time Between Train Events | 6-2 |
| Distribution of Trains in Operation by Hour and Day | 6-3 |
| Number of Cars per Train | 6-4 |
| Monthly Train Lengths by District | 6-7 |
| Message Rate and Message Length - Representative Curves | 6-8 |
| Waybill Input | 6-12 |
| Railroad Activity | 6-13 |
| IBM 7074 - 1301 SYSTEM | 6-14 |
| Introduction | 6-14 |
| Message Entry | 6-14 |
| Program and File Control | 6-15 |
| Supervisory Program Simulation | 6-15 |
| Simulation Statistics | 6-16 |
| Summary | 6-24 |
| SIMULATION OF THE IBM 7750 | 6-24 |
| ANALYSIS OF LINES AND I/O UNITS | 6-27 |
| Introduction | 6-27 |
| Configurations | 6-27 |
| Line Speed | 6-27 |
| Data Entry | 6-28 |
| Generalized Curves | 6-29 |

LIST OF ILLUSTRATIONS

| Figure | | Page |
|--------|---|------|
| 6-1 | On-Line System Configuration of the TOPS System | 6-1 |
| 6-2 | Time Between Train Events (October, 1960) | 6-3 |
| 6-3 | Average Number of Trains on Pacific and Texas and Louisiana Lines (October, 1960) | 6-4 |
| 6-4 | Train Traffic on Pacific and Texas and Louisiana Lines (October, 1960) | 6-5 |
| 6-5 | Thru Originations - Cars per Train (October, 1960) | 6-6 |
| 6-6 | Monthly Train Activity for Two Major Routes on Pacific and Texas and Louisiana Lines (for 1960) | 6-7 |
| 6-7 | Distribution of Mean Input Message Length | 6-8 |
| 6-8 | Distribution of Mean Output Message Length | 6-9 |
| 6-9 | Average Output Message Length from Central Processor | 6-10 |
| 6-10 | Average Input Message Length into Center Processor | 6-10 |
| 6-11 | Average Output Message Volumes from Central Processor | 6-11 |
| 6-12 | Average Input Message Volumes into Central Processor | 6-11 |
| 6-13 | Number of Characters Per Waybill Type | 6-12 |
| 6-14 | IBM 7074 - 1301 System - Distribution of Overall Internal Processing Time | 6-17 |

LIST OF ILLUSTRATIONS
(CONTINUED)

| Figure | | Page |
|--------|--|------|
| 6-15 | IBM 7074 - 1301 System - Response Time For Tracing Inquiries | 6-18 |
| 6-16 | IBM 7074 - 1301 System - Response Time Distribution for Manifest Inquiry | 6-18 |
| 6-17 | IBM 7074 - 1301 System - Queue Time Distribution of Transactions Waiting for a Typical 1301 Disk Storage Module | 6-19 |
| 6-18 | IBM 7074 - 1301 System - Queue Time Distribution of Transactions Waiting for Disk File Channels | 6-20 |
| 6-19 | IBM 7074 - 1301 System - Queue Time Distribution of Transactions Waiting for the Central Processing Unit of the 7074 | 6-21 |
| 6-20 | Variation of Message Rate Compared to the Average IBM 7074 - 1301 Processing Time per Message | 6-22 |
| 6-21 | Variation of Message Rate Compared to the Average IBM 7074 - 1301 Processing Time for Tracing and Manifest Requests | 6-23 |
| 6-22 | Variation of Message Rate Compared to IBM 7074 - 1301 System Disk Storage Access Rate | 6-23 |
| 6-23 | Distribution of Storage Words in the IBM 7750 | 6-25 |
| 6-24 | Cumulative Distribution of Figure 6-23 | 6-26 |
| 6-25 | Output Messages Queued in the IBM 7750 | 6-26 |
| 6-26 | Events Used in the Lines and I/O Unit Analysis (Dallas Street, El Paso) | 6-29 |
| 6-27 | Generalized Wait Time Curves | 6-30 |
| 6-28 | Generalized Input Wait Time Curve (Mean) | 6-31 |
| 6-29 | Generalized Output Wait Time Curve (Mean) | 6-32 |
| 6-30 | Wait Time Curve, Dallas Street, El Paso | 6-33 |
| 6-31 | Queue Length, Dallas Street, El Paso | 6-34 |
| 6-32 | Message Length Curve, Dallas Street, El Paso | 6-35 |

SYSTEM ANALYSIS

INTRODUCTION

This TELE-PROCESSING System was developed with the assistance of simulation and analytical evaluation studies. In addition to many manually conducted studies, the service of a large-scale, scientific computer, the IBM 7090, was employed for 90 hours on simulation and general studies.

The operational system for the railroad responds primarily to random, external stimuli which produce inputs and outputs at the I/O units. Because of this randomness, the approach to system design and evaluation has been through the use of simulation models. The number of units and capacities of the equipment in the configuration of the TOPS System shown in Figure 6-1 have been determined through simulation. The analysis conducted in each of these is described, including representative resultant curves, later in this section.

General analytical studies were conducted prior to the time of the simulation studies to depict characteristics of the Southern Pacific railroad which were needed to build or substantiate simulation techniques and other methods of analysis. Several of these special studies are briefly described in the following discussion.

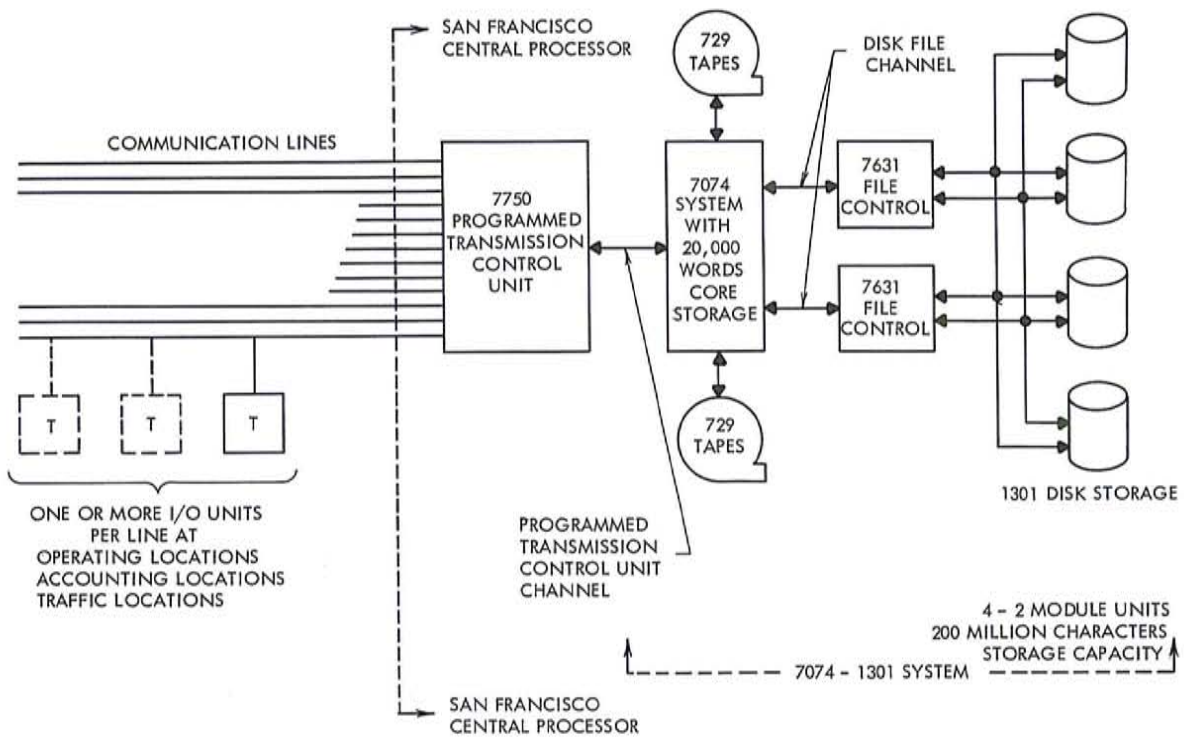

FIGURE 6-1 ON-LINE SYSTEM CONFIGURATION OF THE TOPS SYSTEM

GENERAL STUDIES

Although the number of train originations, terminations, and crew changes at yards was readily available, other important statistics of trains were not.

Train information such as the following had to be derived:

1. Time interval between train originations.
2. Time interval between through train arrivals for intermediate yard crew changes.
3. Time interval between train terminations.
4. Number of trains operating throughout the system at one time.
5. Number of cars on through and local trains.
6. Number of cars picked up and set out by through and local trains.
7. Number of blocks of cars on the average through train.

A second area of importance, because of the large daily volume, is the length, and variation of length of the many types of waybills.

The following studies were conducted and will serve as an illustration of some of the general studies that were completed and their usefulness.

Time Between Train Events

The time between train events in a yard is important, primarily in the design of the communication network and selection of I/O unit equipment.

In this study, the characteristics of trains at twenty-seven yards on the Pacific Lines and Texas and Louisiana Lines were studied. The basic data was the Locomotive Header Cards for all trains during October, 1960.

Typical results of this study are illustrated in Figure 6-2 for the yards at Roseville, Imlay, and Avondale.

At Roseville, 50% of train originations and 50% of train terminations occur within 27 minutes of each other. At Avondale, the interval between originations or terminations is much greater; in fact, only 4% of the train terminations occur within 27 minutes. The capacity of the I/O unit and the communication facility at Roseville compared to Avondale must be greater to handle train activity.

The resultant statistics at Imlay show that 50% of the through train arrivals occur within 53 minutes of each other. While Imlay is not an I/O unit location, Carlin is, and has a similar train arrival rate.

The simulation models used to evaluate the I/O unit equipment requirements and line requirements have incorporated characteristics described above.

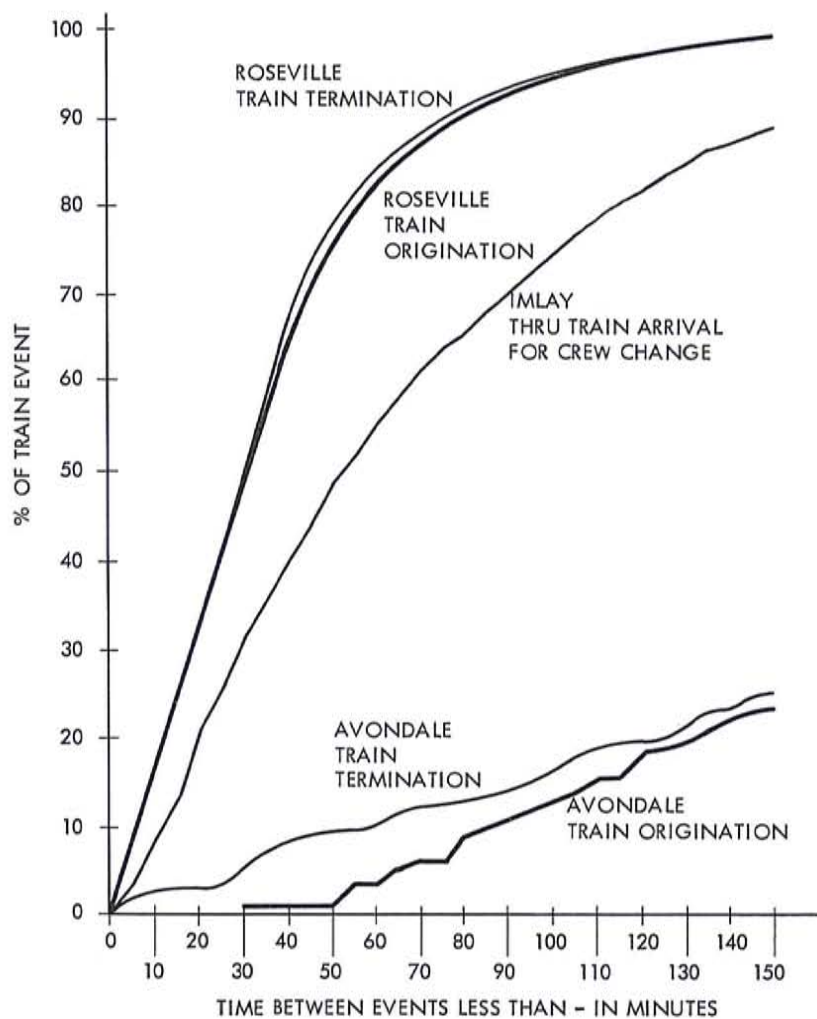

FIGURE 6-2 TIME BETWEEN TRAIN EVENTS (OCTOBER, 1960)

Distribution of Trains in Operation by Hour and Day for the Pacific and Texas and Louisiana Lines (October, 1960)

An estimate of the size of disk storage units for train records required analysis of the number of trains in operation. Locomotive Date Request Cards for October, 1960 containing train number, time of day, and date were sorted according to hour for Figure 6-3 and according to day for Figure 6-4.

Figure 6-3 indicates the hourly distribution for the peak day and low day of through and local trains and the mean hourly distribution for the month. Recognizing that the peak number of trains occurs at noon, disk storage capacity during that period can be evaluated.

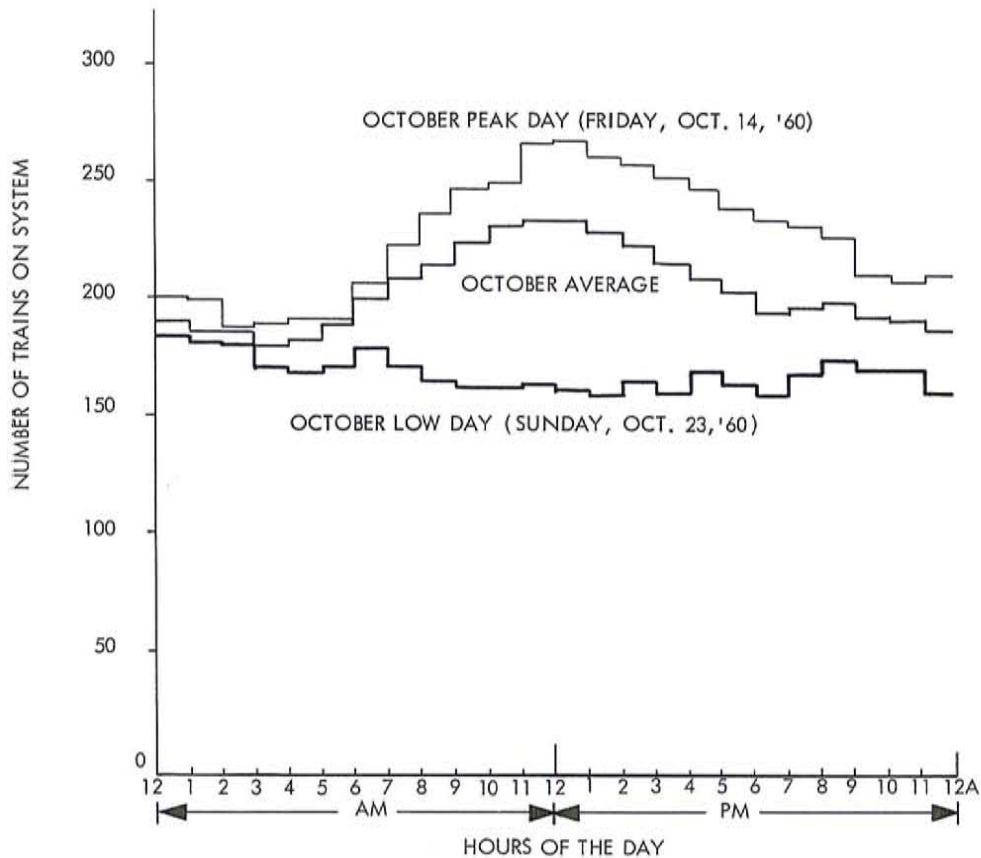

FIGURE 6-3 AVERAGE NUMBER OF TRAINS ON THE PACIFIC AND TEXAS & LOUISIANA LINES (OCTOBER, 1960)

Figure 6-4 contains the results of a study to determine whether there is a large relative difference in number of trains during the days of the week. This study was needed to assure an efficient exploitation of the disk files.

Number of Cars Per Train

The variation of the number of cars on trains is important primarily in the design of the communication network and selection of I/O unit equipment, and of secondary importance in regard to the central processor.

In this study, over 2400 wheel reports (from October, 1960) were examined to determine the following quantities:

1. AT YARDS WHERE TRAINS ORIGINATE
 - a. Number of cars on through trains.
 - b. Number of cars on local trains.

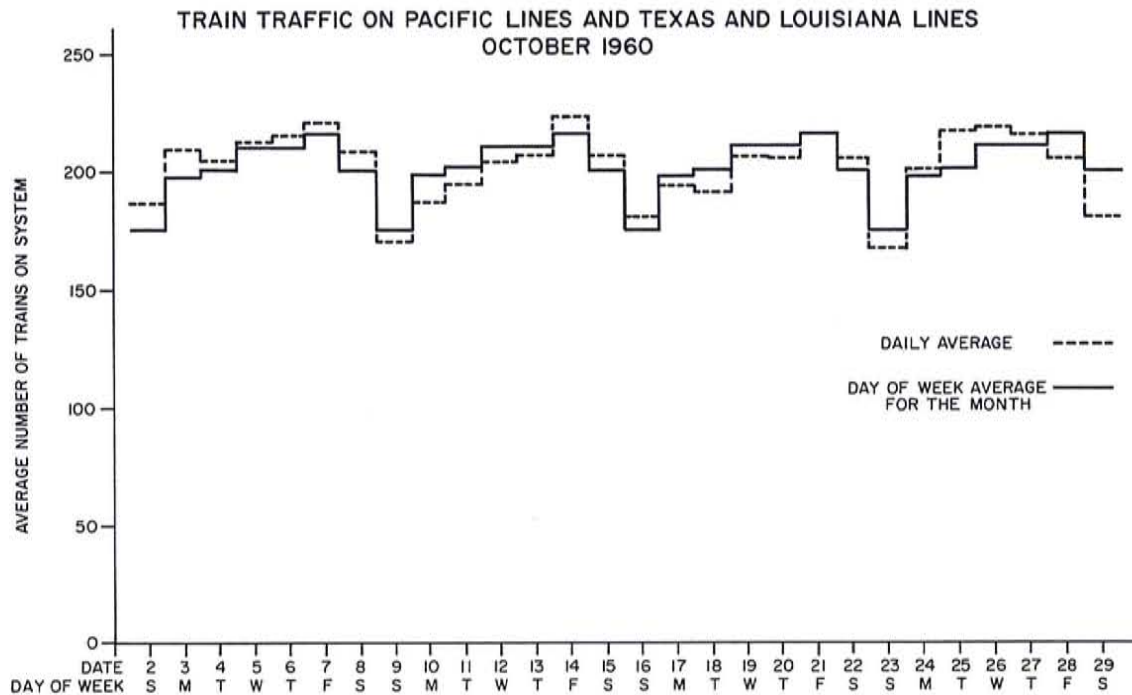

FIGURE 6-4 TRAIN TRAFFIC ON PACIFIC LINES AND TEXAS & LOUISIANA LINES (OCTOBER, 1960)

2. AT YARDS WHERE TRAINS TERMINATE
 - a. Number of cars on through trains.
 - b. Number of cars on local trains.
 - c. Number of cars picked-up.
 - d. Number of cars set-out.
3. AT YARDS WHERE THROUGH TRAINS CHANGE CREWS
 - a. Number of blocks of cars on through trains.
 - b. Number of cars picked-up.
 - c. Number of cars set-out.

Data was tabulated for about twenty locations. The three curves of Figure 6-5 illustrate the typical results found for through train originations. Notice that the Englewood yard has the greatest variation of train length, while at the Roseville yard most of the trains are between 90 and 99 cars (in October, 1960). Ogden, in contrast, has more variation than Roseville; 85% of its trains have between 60 and 100 cars.

This information and other data from the study has been useful in building the simulation models where train consists and the number of cars picked-up and set-out are important.

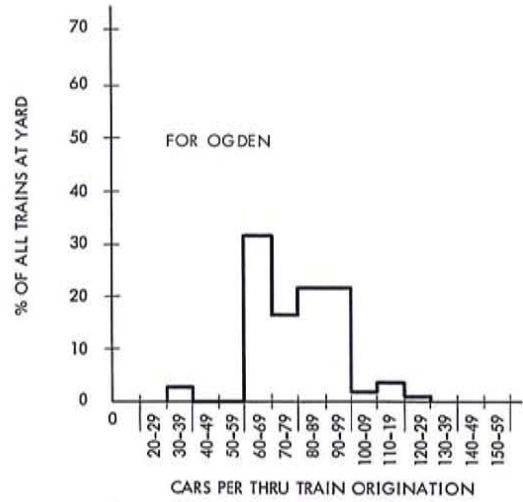
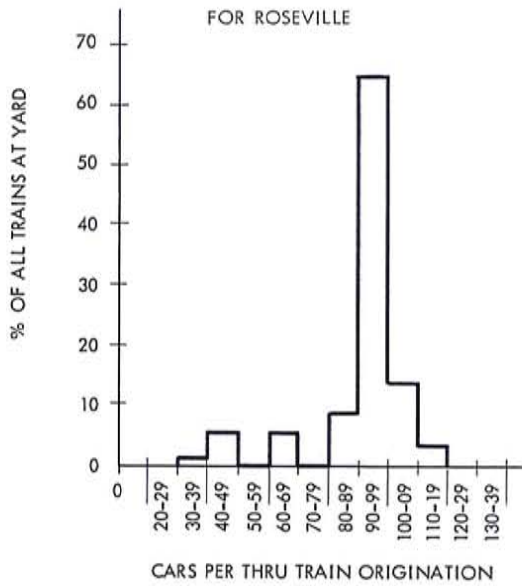
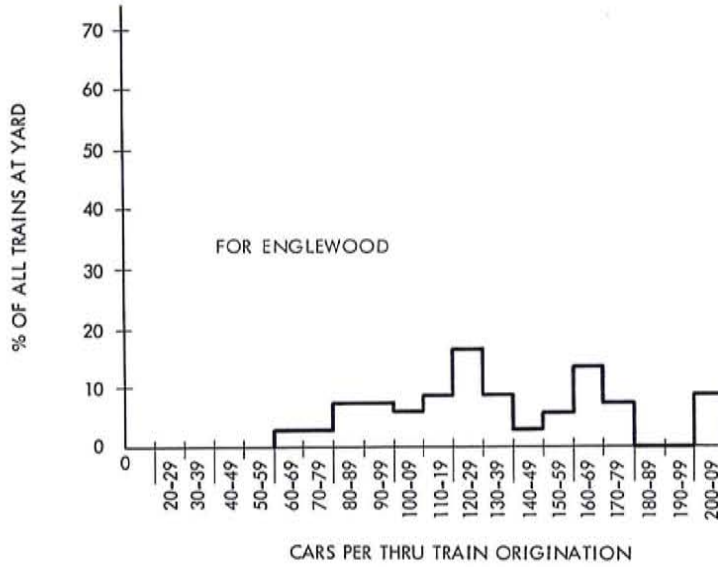

FIGURE 6-5 THROUGH ORIGINATIONS - CARS PER TRAIN (OCTOBER, 1960)

Monthly Train Lengths by District for the Pacific and Texas and Louisiana Lines

Analysis of the efficiency of Freight Locomotive Loading Reports for the year 1960 permitted the analysis of the distribution of through train statistics with respect to the transmission lines which handle the input and output data relating to the trains. Peak line activity analysis was accomplished using this document.

Figure 6-6 depicts the monthly variation of train activity for the Polk, Sacramento, Roseville district, and the Hearne-Ennis district. It was evident that similar analysis had to be made for all train districts if line utilizations were to be correctly evaluated.

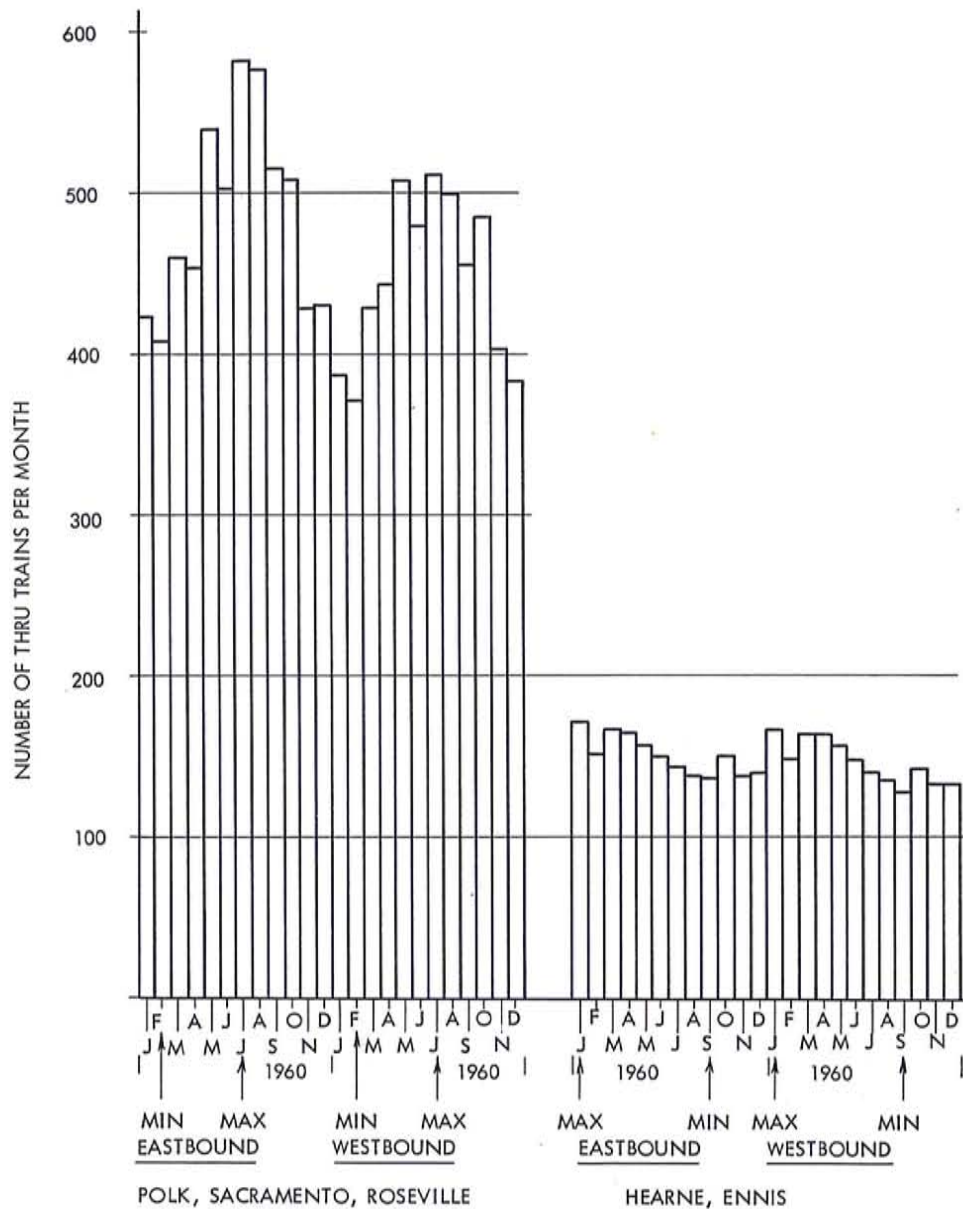

FIGURE 6-6 MONTHLY TRAIN ACTIVITY OF TWO MAJOR ROUTES ON PACIFIC AND TEXAS & LOUISIANA LINES (FOR 1960)

Message Rate and Message Length - Representative Curves

1. Distribution of Input Mean Message Length for 6 a.m. - 9 a.m.

Figure 6-7 illustrates the diversity of message lengths which will be received by the central processor in the period from 6 a.m. to 9 a.m. Only mean message lengths are shown. Some of these means represent wide varieties of lengths within particular message types, such as input consists.

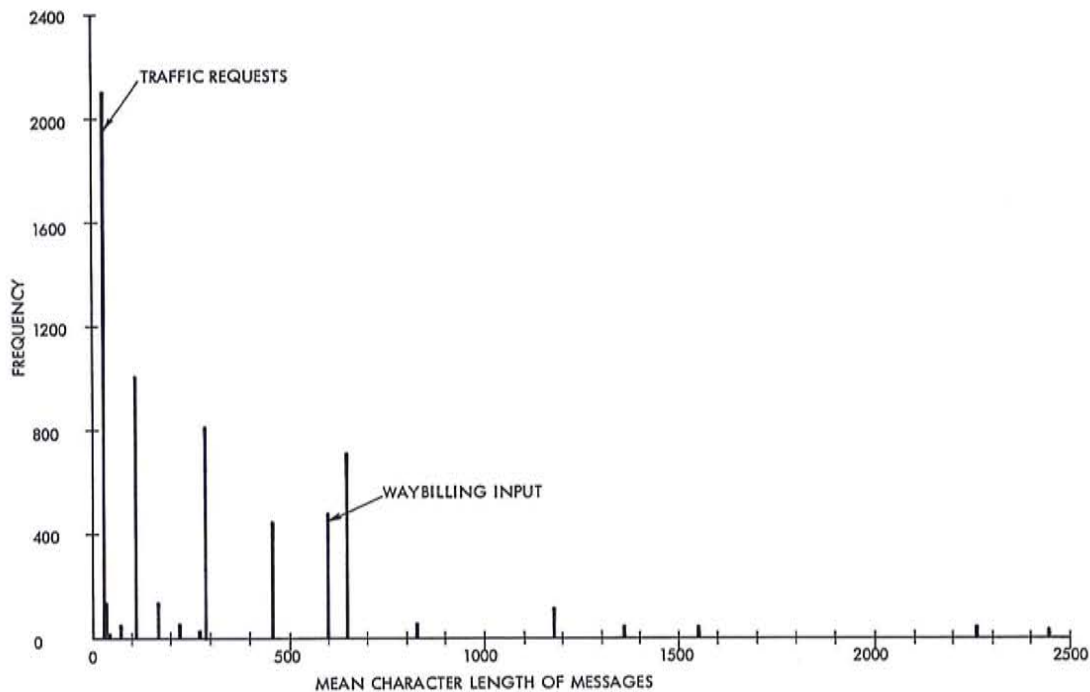

FIGURE 6-7 DISTRIBUTION OF MEAN INPUT MESSAGE LENGTH (6 A.M. to 9 A.M.)

Actual impact on the communications portion of the TOPS System is determined by multiplying a message length by its frequency of occurrence; this gives the total number of characters transmitted. Thus, it may be seen that traffic requests account for less character volume than the input of waybills, even though the frequency of traffic requests is greater.

2. Distribution of Output Mean Message Length for 6 a.m. - 9 a.m.

Figure 6-8 is analogous to the preceding graph, but illustrates output mean message lengths.

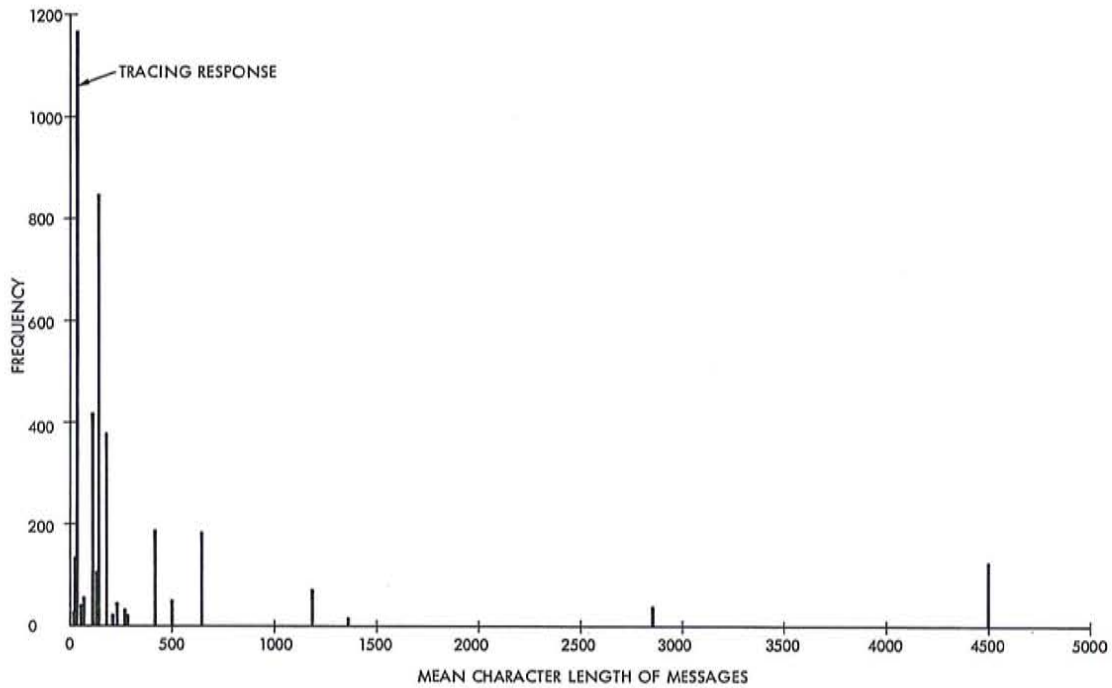

FIGURE 6-8 DISTRIBUTION OF MEAN OUTPUT MESSAGE LENGTH (6 A.M. to 9 A.M.)

3. Average Output Message Length From Central Processor (Figure 6-9).
4. Average Input Message Length Into Central Processor (Figure 6-10).

If curves were drawn similar to those in Figures 6-7 and 6-8 for all other three hour periods, and the average message lengths calculated by weighting each length by its frequency, the data shown on these charts would result.

5. Average Output Message Volumes Out of Central Processor (Figure 6-11).
6. Average Input Message Volumes Into Central Processor (Figure 6-12).

These volumes, if multiplied by the tri-hourly average message lengths would yield the total character volume by three hour intervals.

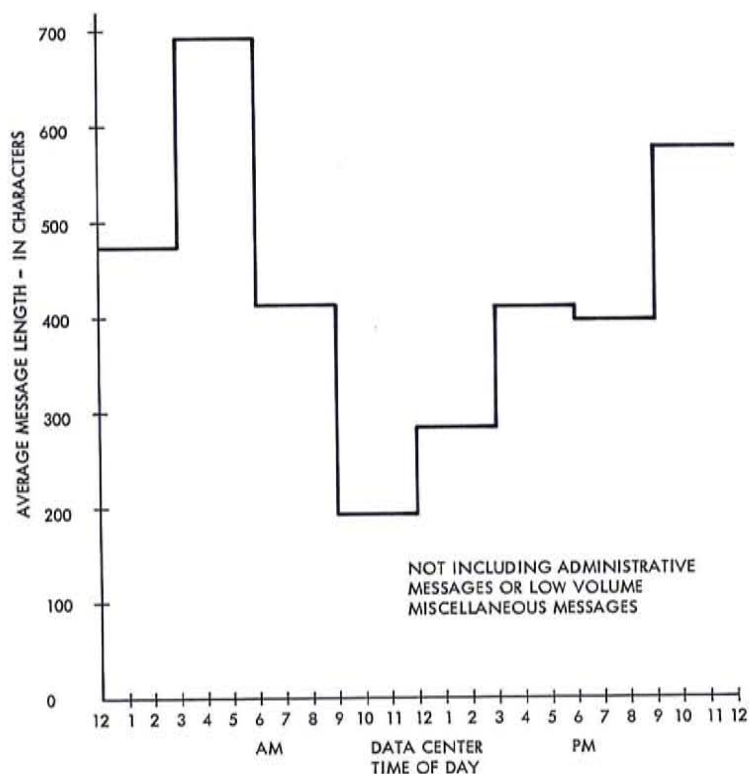

FIGURE 6-9 AVERAGE OUTPUT MESSAGE LENGTH FROM CENTRAL PROCESSOR

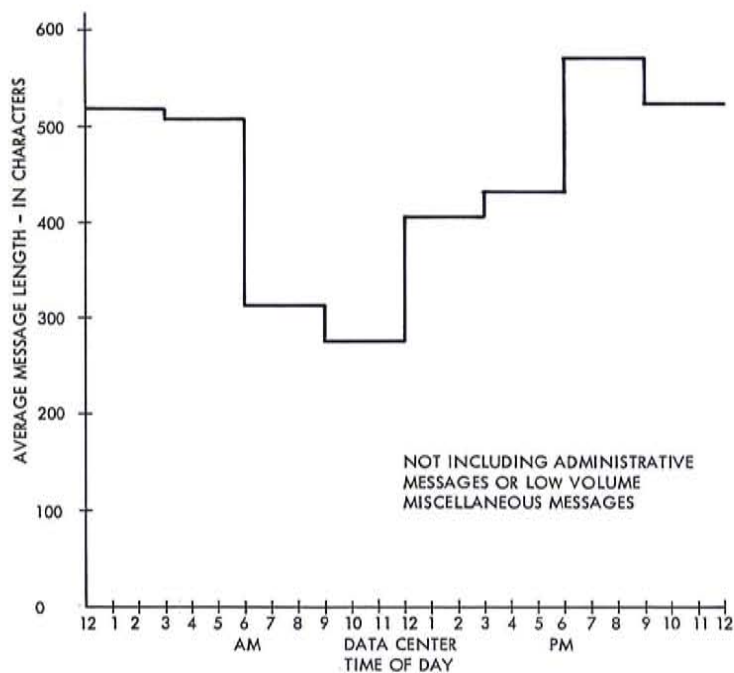

FIGURE 6-10 AVERAGE INPUT MESSAGE LENGTH INTO CENTRAL PROCESSOR

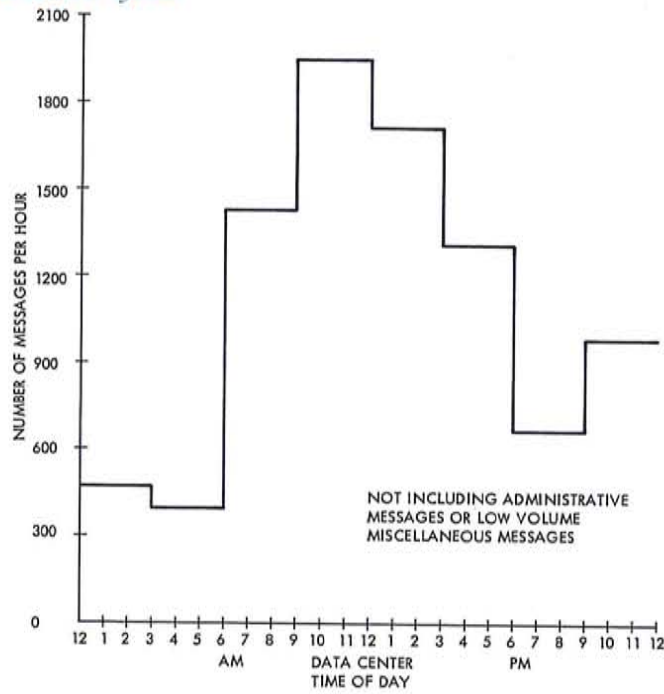

FIGURE 6-11 AVERAGE OUTPUT MESSAGE VOLUMES FROM CENTRAL PROCESSOR

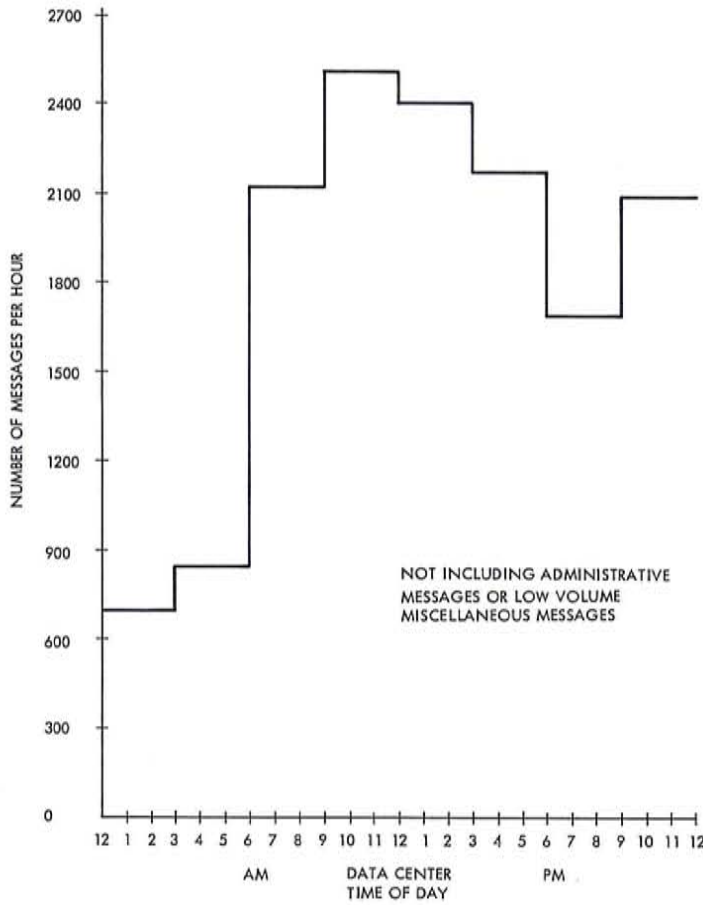

FIGURE 6-12 AVERAGE INPUT MESSAGE VOLUMES INTO CENTRAL PROCESSOR

Waybill Input

The number of characters per waybill (W/B) type, shown in Figure 6-13, was developed from a sample of W/B's obtained during August, 1961.

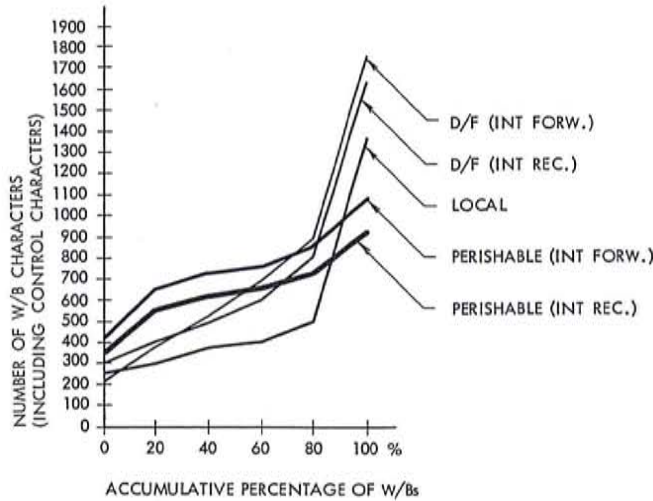

FIGURE 6-13 NUMBER OF CHARACTERS PER WAYBILL TYPE

A count of every character presented on the waybill, as well as stricken characters and control characters, was made. The types of waybills considered were:

| W/B TYPE | NUMBER IN SAMPLE | REMARKS |
|---------------------|------------------|--|
| Perishables | 35 | 7 different origin areas shipping 17 different categories of perishables. |
| Interline Received | 121 | The sample covered Piggy back, Livestock, Perishable, and Transit Freight Waybills. |
| Interline Forwarded | 62 | The sample was composed of Dead Freight Waybills from the four largest shipping centers on the Southern Pacific Lines. |
| Local | 78 | The sample was equally distributed throughout the total region of the Pacific Lines. |

Southern Pacific Company

The particular distribution of W/B lengths per type was employed by the I/O unit simulation in proportion to the mix of products shipped and received at each TOPS waybilling location. An average distribution of all waybills was employed for the IBM 7074 - 1301 system simulation of waybill processing.

Railroad Activity

Railroad activity in the following list was simulated during the period from 6:00 a.m. to 9:00 a.m. This period represents an excellent cross section of events and presents a satisfactory mix of messages and operational programs for system analysis. The input processing, and output specified in the procedures were simulated for each event.

| EVENT AND ASSOCIATED I/O UNIT | NUMBER OF OCCURRENCES |
|---|-----------------------|
| Local Train Originations - I/O unit | 38 |
| Thru Train Originations - I/O unit | 46 |
| Crew Changes, Intermediate Yards - I/O unit | 24 |
| Local Train Terminations - I/O unit | 21 |
| Thru Train Terminations - I/O unit | 48 |
| Train Origination - Card Reader and Transmission Set | 19 |
| Train Terminations - Card Reader and Transmission Set | 18 |
| Crew Changes, Intermediate Yards - Card Reader and Transmission Set | 13 |
| Switchers Going on Duty - I/O unit | 224 |
| Switchers Going off Duty - I/O unit | 215 |
| Switchers Going on Duty - Card Reader and Transmission Set | 18 |
| Switchers Going off Duty - Card Reader and Transmission Set | 13 |
| Change in Car Status - I/O unit | 350 |
| Situation and Turnover Report for a Yard - I/O unit | 110 |
| Transfer Between Yard Complexes - I/O unit | 72 |
| Spots & Pulls - I/O unit | 5577 |
| Car Releases - Card Reader and Transmission Set | 561 |
| Car Orders - I/O unit | 1264 |
| Interchange Cuts Received - I/O unit | 23 |
| Interchange Cuts Delivered - I/O unit | 25 |
| Interchange Cuts Received - Card Reader and Transmission Set | 8 |

| EVENT AND ASSOCIATED I/O UNIT | NUMBER OF OCCURRENCES |
|---|-----------------------|
| Interchange Cuts Delivered - Card Reader and Transmission Set | 7 |
| Waybill Entry - Waybilling and Transmission Set | 481 |
| Tracing Inquiry - I/O unit | 1170 |
| Manifest Inquiry - I/O unit | 222 |
| Diversion Request - I/O unit | 58 |
| Expedite Request - I/O unit | 32 |
| Waybill Data Inquiry - I/O unit | 51 |
| Arrival and Delivery Request - I/O unit | 42 |
| Administrative Messages - I/O unit | 196 |
| Bad Order Notice - I/O unit | 125 |
| Car Releases - (Loads and Empties) - I/O unit | 1552 |

IBM 7074 - 1301 SYSTEM

Introduction

With the aid of simulation, an IBM 7074 - 1301 system has been specified which represents a solution to the total data processing problem posed by the procedures. This solution is achieved with a balanced combination of data processing equipment and program philosophy.

The role of simulation and analysis has been to measure the capability of various configurations and to aid in choosing that configuration which represents optimum capacity at lowest cost, with potential for growth in railroad activity and in new application areas.

With the proposed central processing unit and disk storage (also called disk file) organization, the mean time an application program remains in the processing unit is approximately 2 seconds. Tracing Requests and Manifest Requests require a mean time of less than one second in the processing unit. Thus, their response time can be measured in terms of transmission line and message assembly times.

Graphs are included to show the detailed distributions of response time and the effect on the central processing unit of varying message rates.

Message Entry

Complete and partial messages are transmitted to the IBM 7074 from the IBM 7750 and are assembled and held either in the core storage of the central processor

or disk file storage. Waybills and other long messages are assembled in the disk files prior to IBM 7074 processing. Messages requiring a many-access application program, such as Consists, are assembled and temporarily held in a disk file. Only one many-access program is permitted in the IBM 7074 for processing at any one time. Short messages which require few-access application programs are assembled directly in IBM 7074 core storage.

Program and File Control

The core storage utilization for the application program and the program processing sequence per message type is maximized. Most application programs are stored in disk files.

A central processing unit with twenty thousand words of core storage was selected as the result of simulation. Half of this core storage is used for processing application programs; the other half is used for tables, the supervisory program, and the more frequently employed application programs. The availability of core storage for processing is monitored. As queue in the disk files of many-access program messages becomes evident, the core storage available for few-access programs will be restricted. This procedure assures rapid processing of all application programs and the continuation of processing of the many-access programs. In the absence of the many-access programs, the supervisory program extends all of core storage to the few-access programs.

Processing priority is maintained on a first-come, first-served basis. This priority is established when the application program is first entered into IBM 7074 core storage.

The supervisory program exploits the simultaneous processing features of the IBM 7074. This is vital since there is an order-of-magnitude difference in the time of disk file processing compared to that of the IBM 7074 processing phase of any application program. If the application program presently in process initiates a seek for a record in a disk file or is waiting for the completion of a file operation, another application program may be selected by the supervisory program. IBM 7074 processing also continues as data is being read in and out of core storage.

Supervisory Program Simulation

The order of processing priority as it was developed for the supervisory program is as follows: (In order of highest to lowest priority.)

1. Of highest priority is the IBM 7074 peripheral equipment interrupt.
 - IBM 7074 processing is interrupted and the supervisory program services the particular interrupt.
 - Data Channel service between the IBM 7074 is initiated for the start and termination of input and output data transmissions.
 - Disk file data channel and IBM 1301 file servicing for the initiation and completion of file seek, read, and write operation is provided by the supervisory program.

Southern Pacific Company

2. Messages queued for file processing or IBM 7750 output will be worked as the facilities become available.
3. Interrupted programs will resume processing at the point of interrupt.
4. Messages which have their programs in core storage are queued and processing may commence.
5. Assembled messages are queued and are available for program entry into IBM 7074 core storage.

Simulation Statistics

The IBM 7074 and 1301 system was simulated for the interval between 6 a.m. and 9 a.m. The demand for service within this interval for IBM 7074 and 1301 system processing was established as a reference rate, i. e. 100% level or approximately 1.5 seconds between service demands.

A thorough knowledge of the equipment characteristics has been employed in developing statistics on the operation of the IBM 7074 - 1301 system.

Disk file access time is distributed according to the probability frequency of addressing any disk file address. A special probability function for the Car File access time has been developed since the access and the distribution of Car File records on a disk file is unique.

Probabilistic randomness has also been employed in the selection of message types, message lengths, and message length variations.

General Information - Graphs of Simulation Results (Representative Curves)

Figures 6-14 through 6-19 pertain to results obtained by simulating the period from 6 a.m. to 9 a.m., as described in Part 2. This period, based upon statistics gathered, involves a wide range and typical frequency of message types.

To generalize these results, other message rates which produced file accesses equivalent to all other periods of the day were also simulated. These rates were extended well beyond the peak rate to determine the capacity of the IBM 7074-1301 system. File access rate was used as the criterion because it was found to be the limiting factor.

Figures 6-20 through 6-22 show the relationships discovered.

Figure 6-14 - IBM 7074-1301 System - Distribution of Over-all Internal Processing Time

Internal processing time is considered here to be the total time a particular message remains in the central processing unit. This time is measured from the moment a message is assembled to the moment all processing and file manipulation is complete and any output message is transferred to the IBM 7750. It is important

to note that processing time is not necessarily the execution time of the program. An application program servicing a particular message relinquishes control of the central processing unit to the supervisory program when the application program is delayed for a file access. Much time may be spent waiting for return of the central processor, even after the access is complete. The supervisory program, in this circumstance, may have initiated or re-established processing on another application program.

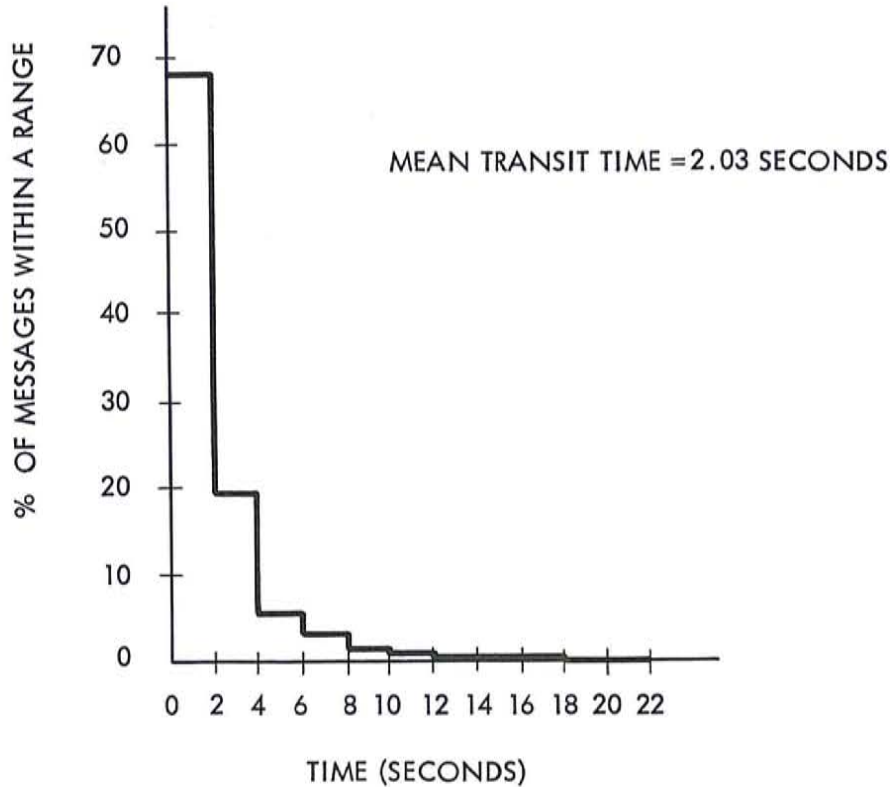

FIGURE 6-14

Figure 6-15 - IBM 7074 - 1301 System - Response Time Distribution For Tracing Inquiries

In this case, the method of measurement is identical to that used in Figure 6-14. (This also does not include message transmission time.)

The shorter response time here, as compared to Figure 6-14, is accounted for by the fact that a tracing inquiry involves only one file access and very little processing.

Figure 6-16 - IBM 7074-1301 System - Response Time Distribution For Manifest Inquiry

This chart is identical in meaning to Figure 6-15. Response time for this message is higher than for a tracing inquiry because two file accesses are required.

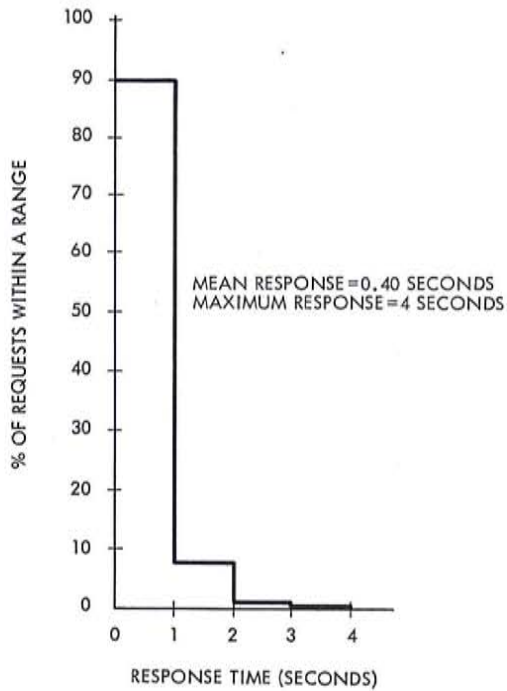

FIGURE 6-15

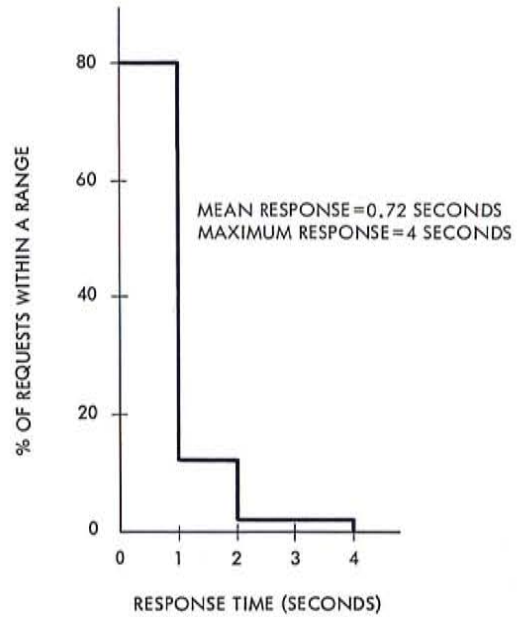

FIGURE 6-16

Figure 6-17 - IBM 7074 - 1301 System - Queue Time Distribution of Transactions Waiting For a Typical 1301 Disk Storage Module

Most of the time used in processing a message is spent in waiting for, or making, disk file accesses. Because all of the files and their copy records are distributed equally over eight modules, all eight modules will be equally utilized.

The wait times shown on this graph apply only to those accesses which could not be performed immediately. Forty percent of the total accesses were initiated without delay, and are therefore not included on this graph.

This distribution of wait times applies to accesses, not messages. A particular message could involve many accesses.

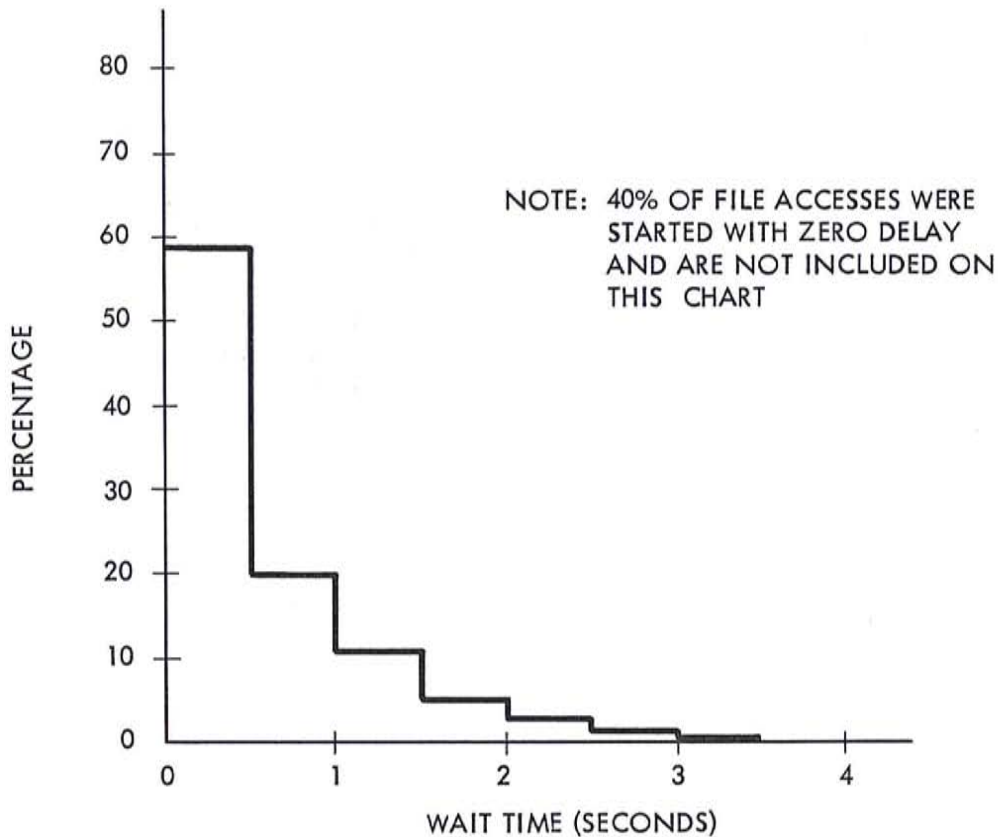

FIGURE 6-17

Figure 6-18 - IBM 7074 -1301 System - Queue Time Distribution of Transactions Waiting for Disk File Channels

In this case, the scale of time is much shorter than that in Figure 6-17. Disk file channels are used for two basic purposes:

1. Control information transfer.
2. Data transfer in reading or writing.

Control information transfer accounts for only a small percentage of disk file channel use. Data transfer is accomplished at a rate much faster than the motion of the access mechanisms in seeking data.

The 70% of data transmissions which had no queue delays are not included in the graph.

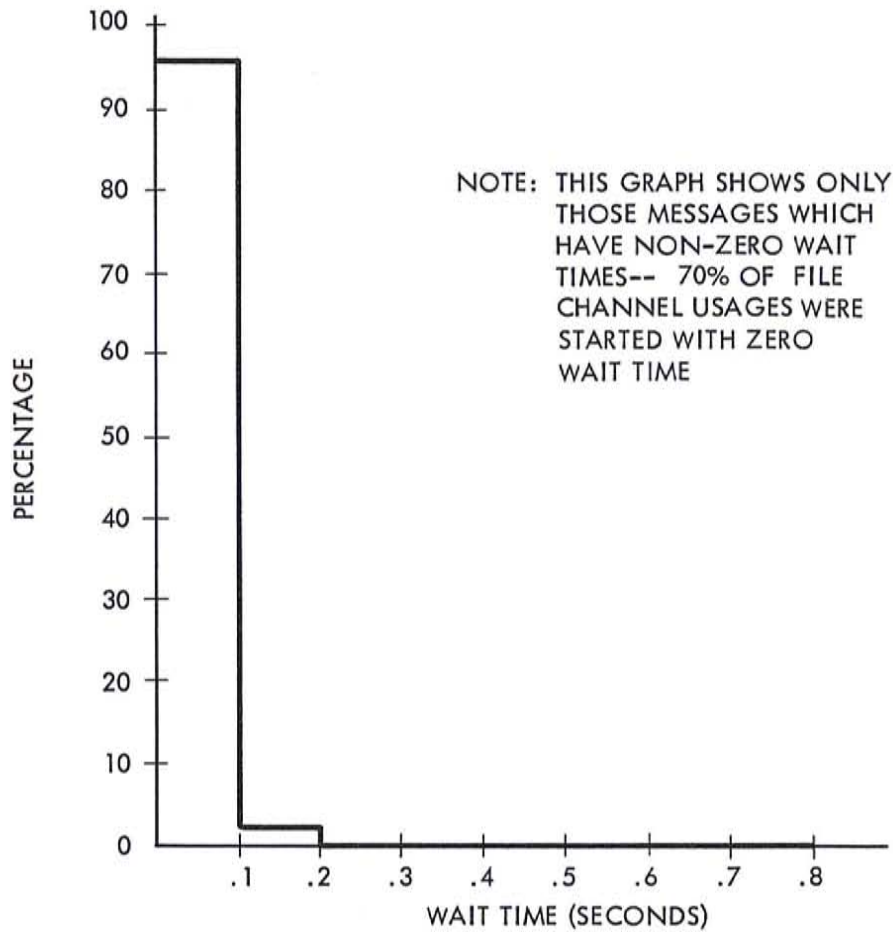

FIGURE 6-18

Figure 6-19 - IBM 7074 - 1301 System - Queue Time Distribution of Transactions Waiting For the Central Processing Unit of the 7074.

Only 8% of the central processor utilizations involved any waiting for central processor availability. The rest are not shown.

This illustration, coupled with Figure 6-18, helps to demonstrate that most internal queuing is due to disk files.

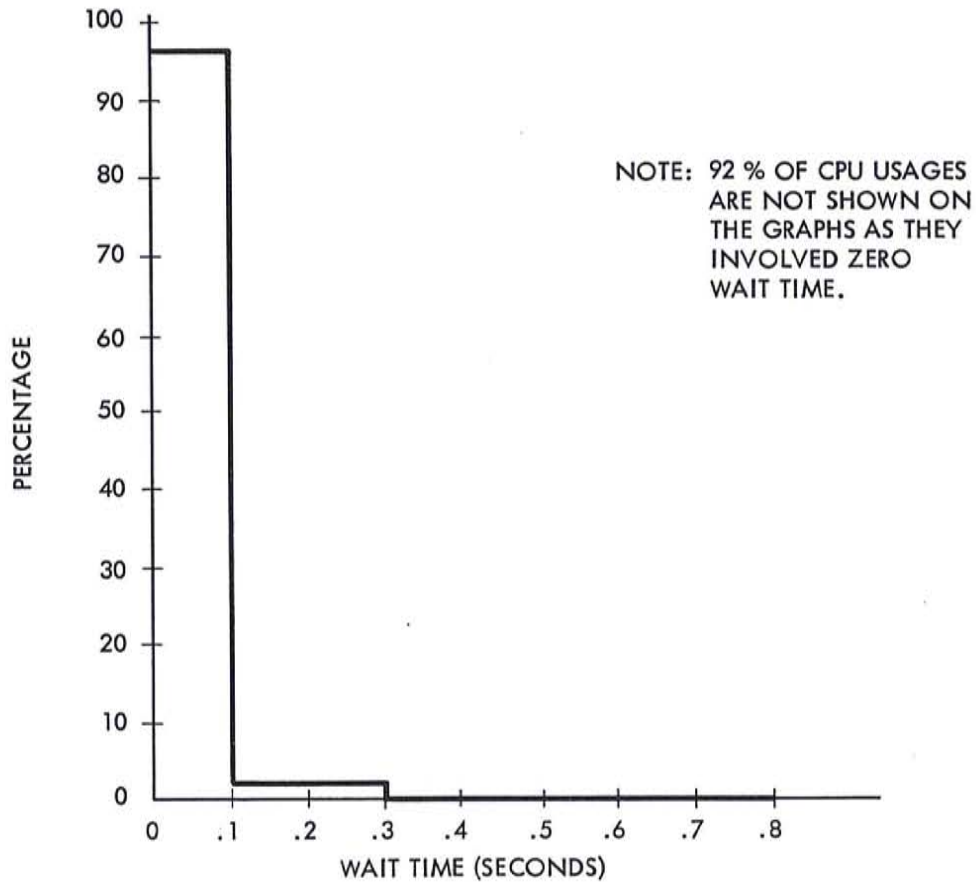

FIGURE 6-19

Figure 6-20 - Variation of Message Rate Compared to the Average IBM 7074 - 1301 Processing Time Per Message

Processing time has the same meaning here as in Figure 6-14. Figure 6-20 is the plot of means of processing time distributions which are similar to Figure 6-14, but with different message rates. The shapes of the Figure 6-14 type curves vary, but the mean is indicative of where it would lie with respect to the 100% message rate that is plotted in Figures 6-14 through 6-19. This 100% message rate corresponds to the activity between 6:00 a.m. and 9:00 a.m. The other points are relative to this maximum capacity of the IBM 7074-1301 system. The peak period of the day falls well below this maximum providing ample reserve capacity for short term peaks and additional applications.

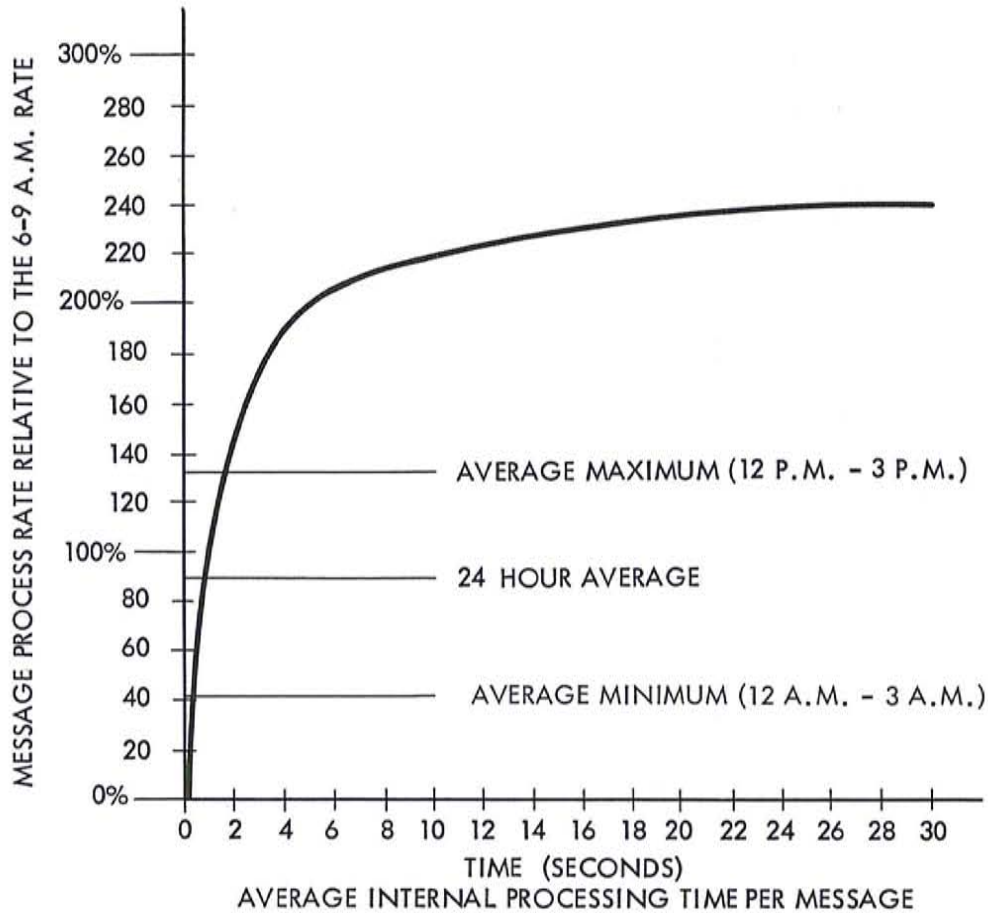

FIGURE 6-20

Figure 6-21 - Variation of Message Rate Compared to the Average IBM 7074 - 1301 Processing Time for Tracing and Manifest Requests

This graph is analogous to Figure 6-20, but for tracing and manifest inquiries only. The time scale is smaller by an order of magnitude. On the same scale as Figure 6-20, the change in response time would be negligible.

Figure 6-22 - Variation of Message Rate Compared to IBM 7074 - 1301 System Disk Storage Access Rate

The percentage message rate is relative to the 6 a.m. - 9 a.m. period.

This illustration shows a reserve capacity of 48% in file access capability. When growth and new applications exceed this reserve, additional capacity may be added by increasing the number of access mechanisms.

The point where maximum capacity is indicated is that point where the IBM 7074-1301 system could no longer process messages as rapidly as they are entered.

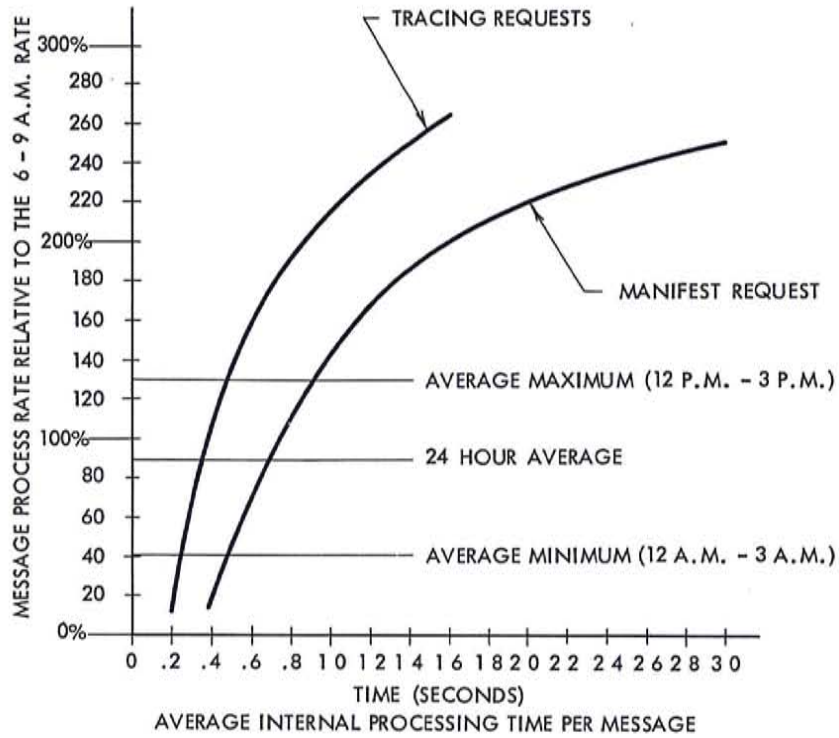

FIGURE 6-21

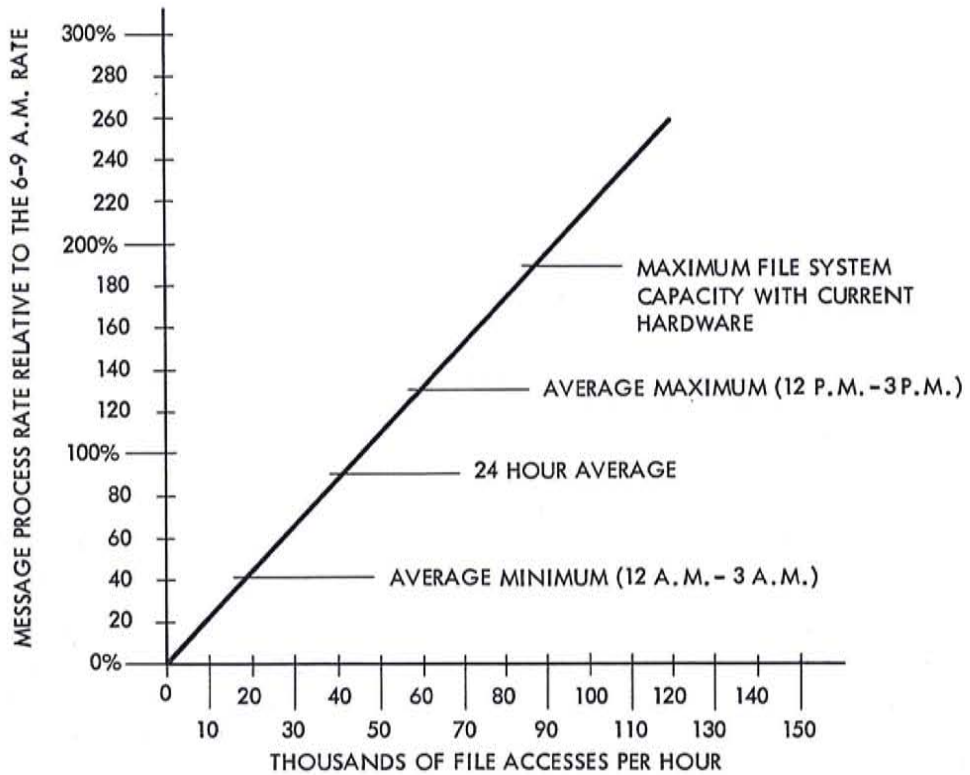

FIGURE 6-22

Summary

With the specified IBM 7074 - 1301 system, there is adequate capacity to perform those functions required by the procedures. Response times, as shown in the graphs, are well within the anticipated processing interval.

Three avenues are open for possible expansion:

1. With present techniques and hardware, the IBM 7074 - 1301 system is capable of a throughput which is double the average daily message rate.
2. With present equipment, more sophisticated methods of accessing disk file records can yield greater file efficiency. This becomes a dominant factor as the IBM 7074 - 1301 system becomes heavily loaded.
3. Additional equipment in the form of disk files, disk file channels and core storage can increase capacity significantly.

SIMULATION OF THE IBM 7750

The IBM 7750 was simulated to determine the amount of storage required. The time interval simulated was the 6:00 a.m. to 9:00 a.m. period. This is the peak throughput period for the TOPS System. The line speed simulated was 14.8 characters/second. The polling scheme used is explained in the Analysis of Lines and I/O Units, which follows this discussion.

The parameters assumed for the simulation are as follows:

1. The maximum block length received from the central processor is 495 characters.
2. The maximum output queue permitted in the IBM 7750 is 3 messages per line, or a total of 100 messages for all lines.
3. Input messages are transmitted to the central processor either after the end of message character, or in partial form after the first longitudinal redundancy check of each 100 characters of input.

The distribution of line utilizations used in the simulation was developed from the line layouts and the I/O unit statistics.

The simulations confirmed that the maximum capacity of the IBM 7750 required for the TOPS System is 16,000 words, of which 7,000 are needed for the control program. Figures 6-23, 6-24, and 6-25 are results from a typical simulation run.

Figure 6-23 is a plot of the distribution of storage words used in the IBM 7750. When a control program storage words have been added the mean utilization of storage during the run is 12,250 words. The lower limit and upper utilization limits were 10,000 and 14,250 words respectively. The curve is normally distributed about the mean.

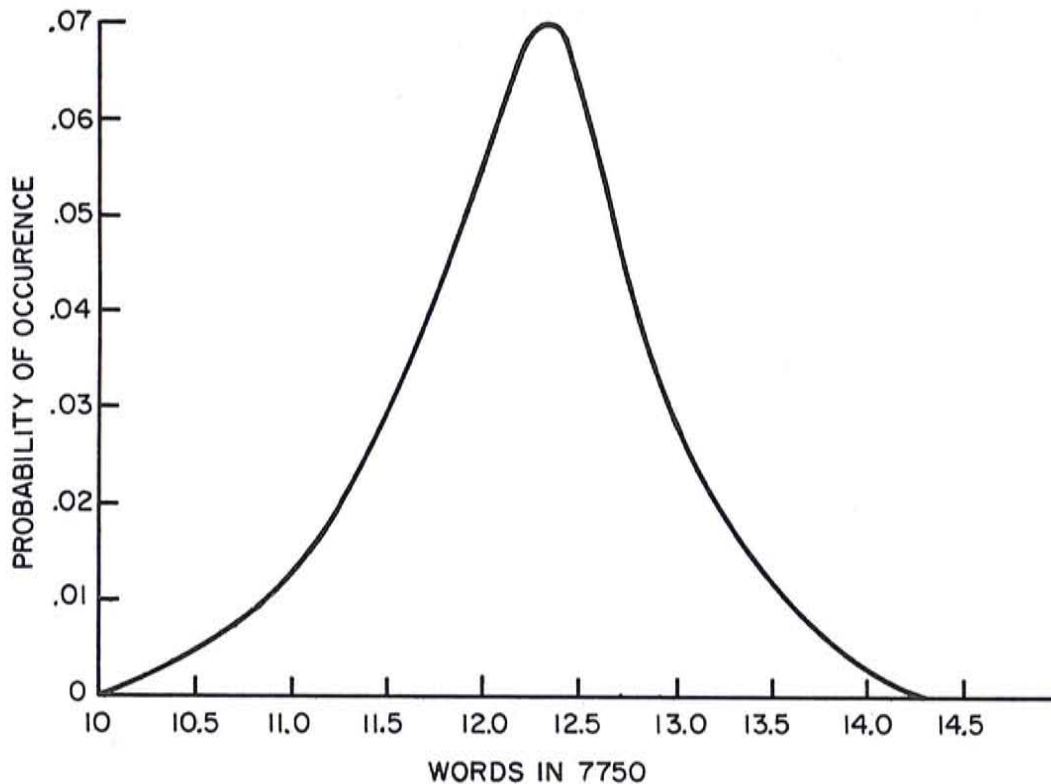

FIGURE 6-23 DISTRIBUTION OF STORAGE WORDS IN THE IBM 7750

Figure 6-24 is the cumulative distribution of Figure 6-23 and shows the probability of using less than the number of storage words shown on the horizontal axis. Note that the probability is .9 of using 13,100 words or less, or probability is .1 of using more than 13,100 words of storage.

Figure 6-25 is a plot of the number of messages queued in the IBM 7750 for output. The minimum and maximum number of messages observed in the IBM 7750 during this sample was 30 and 70, respectively, with a mean of 50.

The storage of administrative messages for off-line traffic offices was not taken into consideration in the IBM 7750 simulation. From the statistics available on the 6:00 a.m. - 9:00 a.m. period, the IBM 7750 will have an average throughput of 243 administrative messages. From the curve in Figure 6-23, at least 1,750 words or 7,000 characters are available during the simulated period.

The mean length of an administrative message is approximately 300 characters; this will allow an average of 23 administrative messages to be stored at one time. Assume that each message is in the IBM 7750 for one and one-half minutes (wait time plus transmission time). This specification would give a theoretical throughput rate of 2,760 messages in the peak 3-hour period; this is well above the empirically estimated 243 messages. There is a significant increase in administrative message throughput when the upper limit of non-administrative output messages is reduced from 3 to 2 per line.

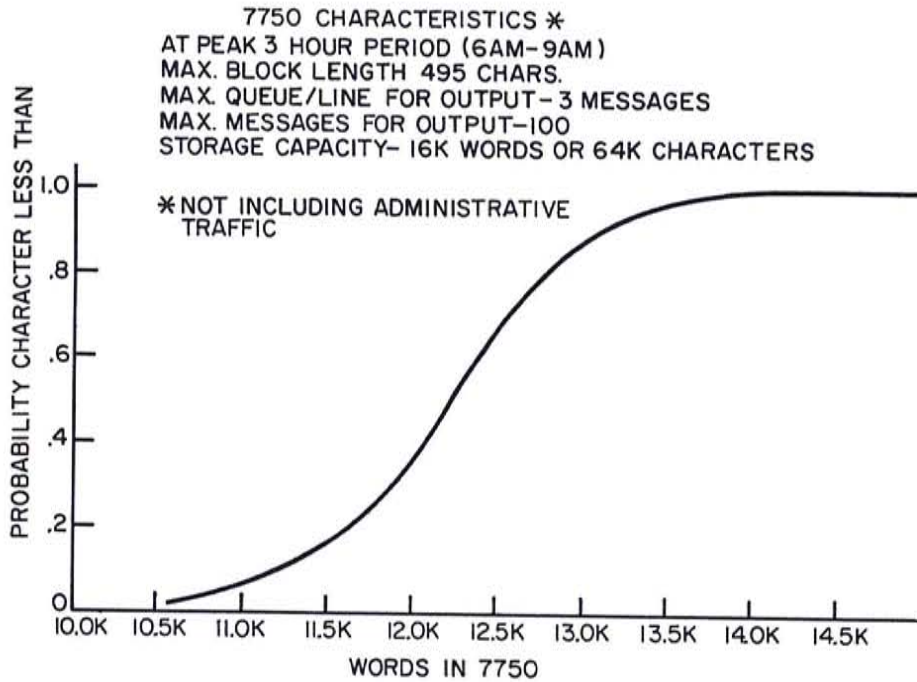

FIGURE 6-24 CUMULATIVE DISTRIBUTION OF FIGURE 6-23

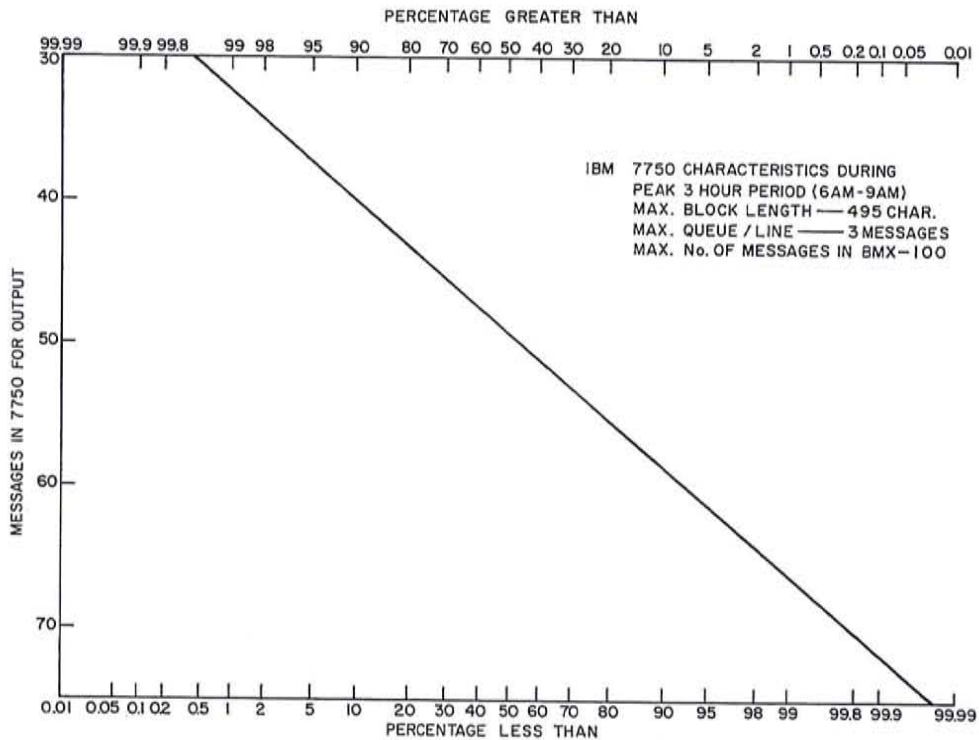

FIGURE 6-25 OUTPUT MESSAGES QUEUED IN THE IBM 7750

ANALYSIS OF LINES AND I/O UNITS

Introduction

Criteria for the analysis of lines and I/O units was developed using a set of generalized curves which are characteristic of railroad performance and statistics.

Within the structure of a mathematical model, various configurations of I/O units were considered for the purpose of producing generalized utilization curves. From the analysis of these curves, a specific design for a line layout can be developed.

The order of polling and selection is one of many parameters which effect the shape of both generalized and specific line utilization curves. The polling and selection scheme that was simulated reflects three modes of operation: output message transmission, high priority input transmission and low priority input transmission. For each line:

1. Queued output messages are sent until exhaustion.
2. All traffic, car distributor, car dispatcher and operating I/O units listed in the high priority table are polled and serviced sequentially.
3. If there was an input message, the cycle is restarted. Otherwise, I/O units in the low priority table are polled; these are the TOPS waybilling points.
4. Polling terminates when one pass is made through the low priority table or when one waybill is serviced. The cycle is then restarted.

Configurations

Various configurations of I/O units were simulated in the model:

1. Operating
2. Traffic (on and off-line)
3. Waybilling
4. Dispatcher
5. Combinations of the above

The utilizations of I/O units were developed using various mixes of equipment. Operating I/O units were either dedicated to a line or used in combination with off-line processing.

Line Speed

The line speed used in the simulation was 9 characters per second for off-line traffic I/O Units and 14.8 characters per second for all on-line I/O Units.

Data Entry

An example of empirical railroad events used in the simulation is shown in Figure 6-26. This data is for the I/O units at Dallas Street, El Paso. The simulation statistics are summarized in the following table.

| EVENT | AVERAGE OBSERVED FREQUENCY Dallas Street - El Paso I/O Units |
|--|---|
| 1. Thru Originations | 14 |
| 2. Local Originations | 1 |
| 3. Crew Changes | 0 |
| 4. Thru Terminations | 9 |
| 5. Local Terminations | 1 |
| 6. Interchange Received | 15 |
| 7. Interchange Delivered | 16 |
| 8. Releases - Loads | 70 |
| 9. Car Orders | 70 |
| 10. Releases - Empties | 80 |
| 11. I.S.C. Activity (Spots & Pulls List) | 4 each per shift |
| 12. Turn Around Local Trains | 0 |
| 13. Advance Arrival Notices | 76 |
| 14. Switcher Activity | 5 each per shift |
| 15. Status Changes | 570 |
| 16. Car Servicing | 130 |
| 17. Situation Turnover Reports | 4 |
| 18. Volume Interchange Report | 1 |
| 19. Transfer | 9 |
| 20. Waybilling | 263 |
| 21. Dispatcher Activity | 0 |
| 22. Tracing Request | 0 |
| 23. Manifest Request | 0 |
| 24. W/B Request | 0 |
| 25. Diversion Request | 0 |
| 26. Arrival and Delivery | 0 |
| 27. Expedite | 0 |
| 28. Historical Tracing | 0 |
| 29. Bad Order | 0 |
| 30. Special Accounts | 0 |
| 31. Administrative Messages | 0 |

JUNE 1960 - 61 STATION NAME DALLAS STREET, EL PASO NO. 71181

| | 12A | 3A | 6A | 9A | 12P | 3P | 6P | 9P | 12A | TOTAL |
|--------------------------|----------------------|------|------|------|------|------|------|------|------|-------|
| THRU TRAIN ORIGINATIONS | 1.95 | 2.12 | 1.57 | 2.12 | 1.53 | 0.81 | 0.68 | 0.68 | 1.66 | 11.0 |
| LOCAL TRAIN ORIGINATIONS | 0 | 0 | 0 | 0 | 0 | 0 | 0 | 0 | 0 | 0 |
| INTERMEDIATE YARD | 0 | 0 | 0 | 0 | 0 | 0 | 0 | 0 | 0 | 0 |
| THRU TERMINATIONS | 2.98 | 2.73 | 0.79 | 1.15 | 1.63 | 2.10 | 2.57 | 2.05 | 16.0 | |
| LOCAL TERMINATIONS | 0.16 | 0.14 | 0.15 | 0.08 | 0.10 | 0.07 | 0.16 | 0.14 | 1.0 | |
| YARD ACTIVITY | TRANSFERS | | | | | | | | | |
| INTERCHANGE | 1.0 | 1.0 | 1.0 | 1.0 | 1.0 | 1.0 | 1.0 | 1.0 | 1.0 | 8.0 |
| ICS ACTIVITY | 1.0 | 1.0 | 1.0 | 1.0 | 1.0 | 1.0 | 1.0 | 1.0 | 1.0 | 8.0 |
| | 1.82 | 1.99 | 1.82 | 1.99 | 1.08 | 1.32 | 0.91 | 2.07 | 13.0 | |
| | 1.16 | 1.85 | 1.44 | 0.82 | 0.75 | 0.75 | 1.37 | 1.85 | 10.0 | |
| | TURN - AROUND LOCALS | | | | | | | | | |
| | 0 | 0 | 0 | 0 | 0 | 0 | 0 | 0 | 0 | 0 |
| | 0 | 0 | 0 | 0 | 0 | 0 | 0 | 0 | 0 | 0 |
| | SHIFT | | | | | | | | | |
| | NO. OF SPOT LISTS | | | | | | | | | |
| | CARS SPOTTED | | | | | | | | | |
| | CARS PULLED | | | | | | | | | |
| | PULLED INTO YARD | | | | | | | | | |
| | 1 | 2 | 3 | 4 | 5 | 6 | 7 | 8 | 9 | 10 |
| | 8 | 3 | 4 | 24 | 24 | 24 | 24 | 24 | 24 | 24 |
| | 16 | 16 | 16 | 16 | 16 | 16 | 16 | 16 | 16 | 16 |

| | 1 | 2 | 3 | TOTAL |
|------------------------|----|-----|----|-------|
| WAYBILLS | | | | |
| INIT REC | 36 | 36 | 36 | 108 |
| PER + LIV'K ORIGINATED | 26 | | | 26 |
| LOCAL | 29 | | | 29 |
| INT FWD | 33 | | | 33 |
| EMPTY CAR | 2 | 2 | 2 | 6 |
| ADV ONLY | 8 | 8 | 9 | 25 |
| TOTAL | 46 | 134 | 47 | 227 |

FIGURE 6-26 EVENTS USED IN THE LINES AND I/O UNIT ANALYSIS (DALLAS STREET, EL PASO)

Generalized Curves

Figures 6-27 through 6-30, are used for the design of the line layout for operating and/or waybilling I/O units. Using many possible configurations of I/O units, a family of similar curves was obtained. The upper boundary curve describes the performance of a duplexed I/O unit where one, a dedicated I/O unit, is always attached to the communication line and the other is used for local processing or on the communications line as required. The lower boundary describes the single I/O unit which is used on or off the communications circuit.

The three distinct priority classes in the polling scheme produce the disjoint in the input and output curves. The parameters which determine the shape of the curves fall into the following three categories:

1. Message size distribution
2. Polling scheme
3. Ratio of input to output

The shape of the curves are independent of line speeds. Variation of line speeds will inversely affect the line utilization.

Figure 6-27 - Generalized Wait Time Curves (90th Percentile)

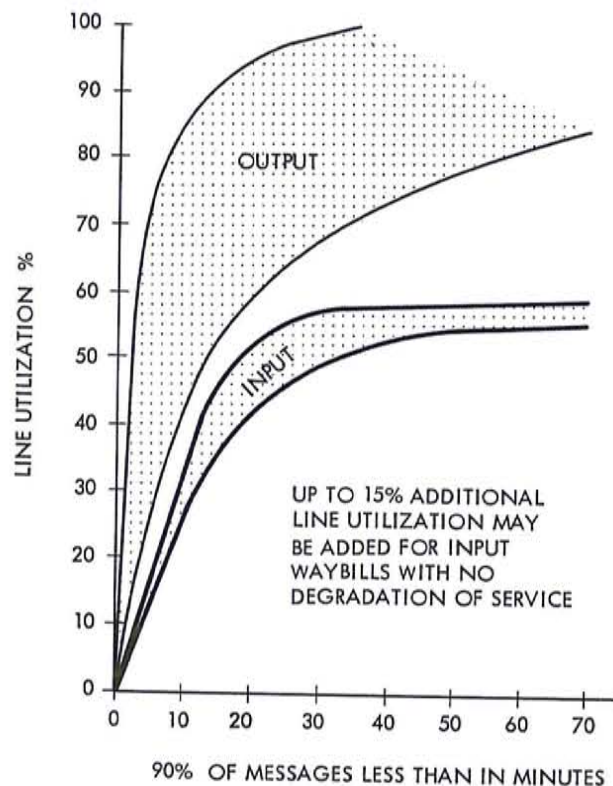

FIGURE 6-27

Generalized design curves for line layouts are a plot of line utilization versus 90th percentile of message wait time. Analysis shows that a 30% to 45% utilization results in a message wait time of less than 15 minutes for 90% of all operational input messages. Half of the messages have a wait time less than 5 minutes and many of these have immediate service. Up to 15% additional line utilization may be added for input waybills without degradation of service time. The simulated message wait times are over a 24-hour period.

Figure 6-28 - Generalized Input Wait Time Curve (mean)

Input messages for operating I/O units are shown as the functions of line utilization versus mean wait time. Using Dallas Street, El Paso as a typical example, a 47% line utilization gives a mean input wait time of 4.1 minutes over a 24-hour time period.

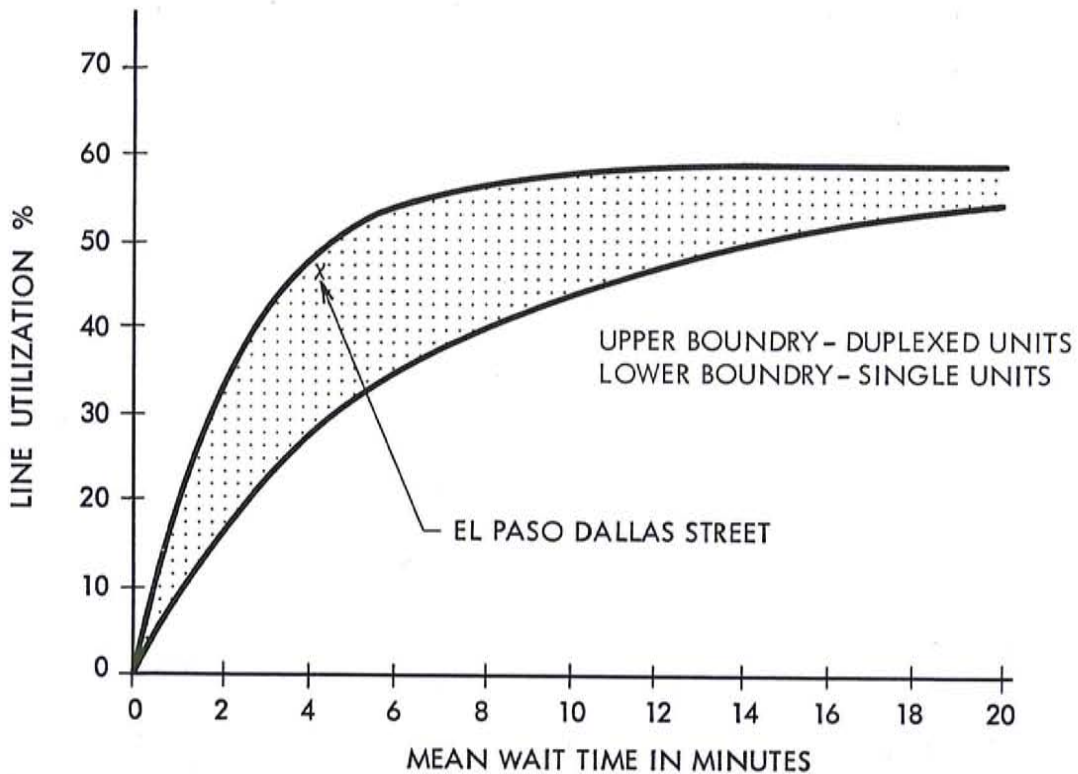

FIGURE 6-28

Figure 6-29 - Generalized Output Wait Time Curve (mean)

In the general output wait time curve for operating I/O units, the Dallas Street, El Paso I/O unit has a mean output message wait time of 1.2 minutes over a 24-hour period.

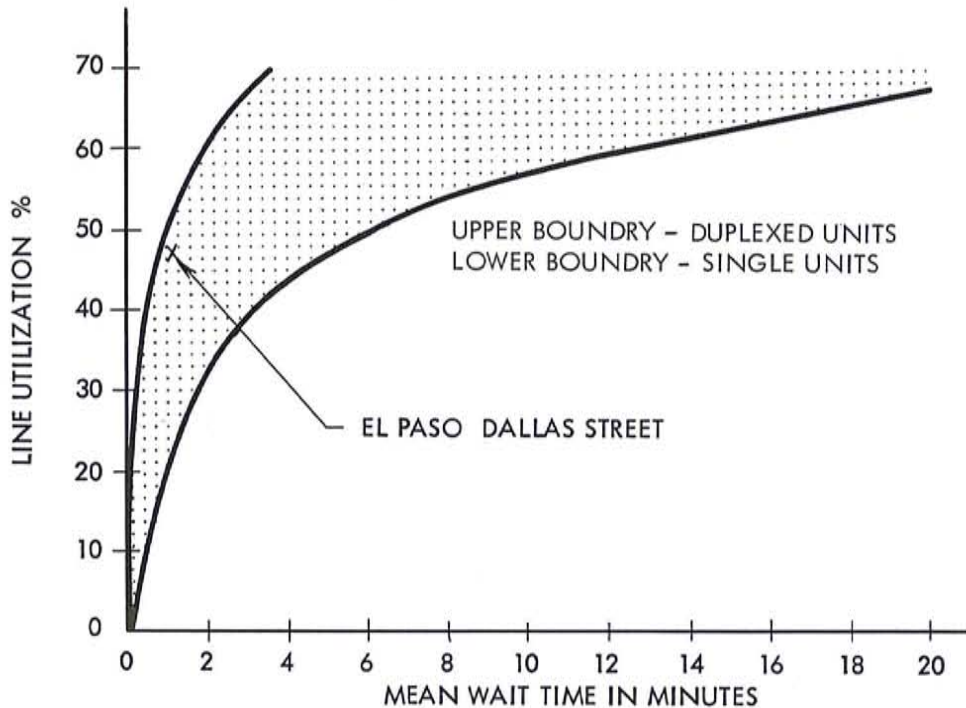

FIGURE 6-29

Figures 6-30, 6-31 and 6-32 - Wait Time, Queue and Message Length Curves

Wait time, queue length, and the message length curves are representative of a typical combined operating - waybilling I/O unit at Dallas Street, El Paso. This is a duplexed I/O unit which has been simulated over a typical twenty-four hour day.

The observed frequency of each event is shown in Figure 6-26. The simulated line utilization for Dallas Street, El Paso is 47%. This represents an assumption that 15% of Dallas Street inputs and outputs will be handled by the second I/O unit which is primarily used for local operators.

Figure 6-30 - Wait Time Curve, Dallas Street, El Paso

The curve for output shows that for 90% of the time, the wait is less than five minutes. On input, 90% of the time the wait is less than twelve minutes.

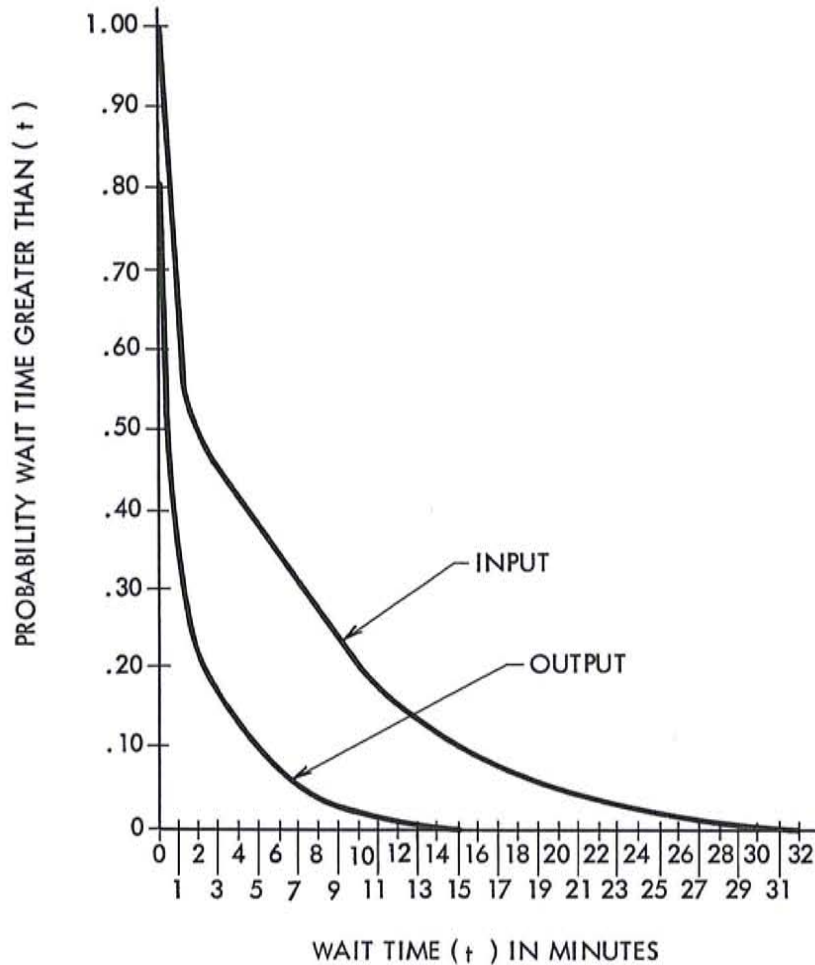

FIGURE 6-30

Figure 6-31 - Queue Length, Dallas Street, El Paso

Queue length distribution is the result of a periodic sampling of the number of messages in the queue on input and output during the simulation run.

In actual practice, the input queue will probably be shorter than shown, because no attempt was made to simulate the work schedule of a yard office.

For 69% of the time there is no input queue, and for 90% of the time there is no output queue. These percentages exclude the message being transmitted on the communication line.

Input and output queue lengths vary with the message input to output ratio and the choice of polling scheme.

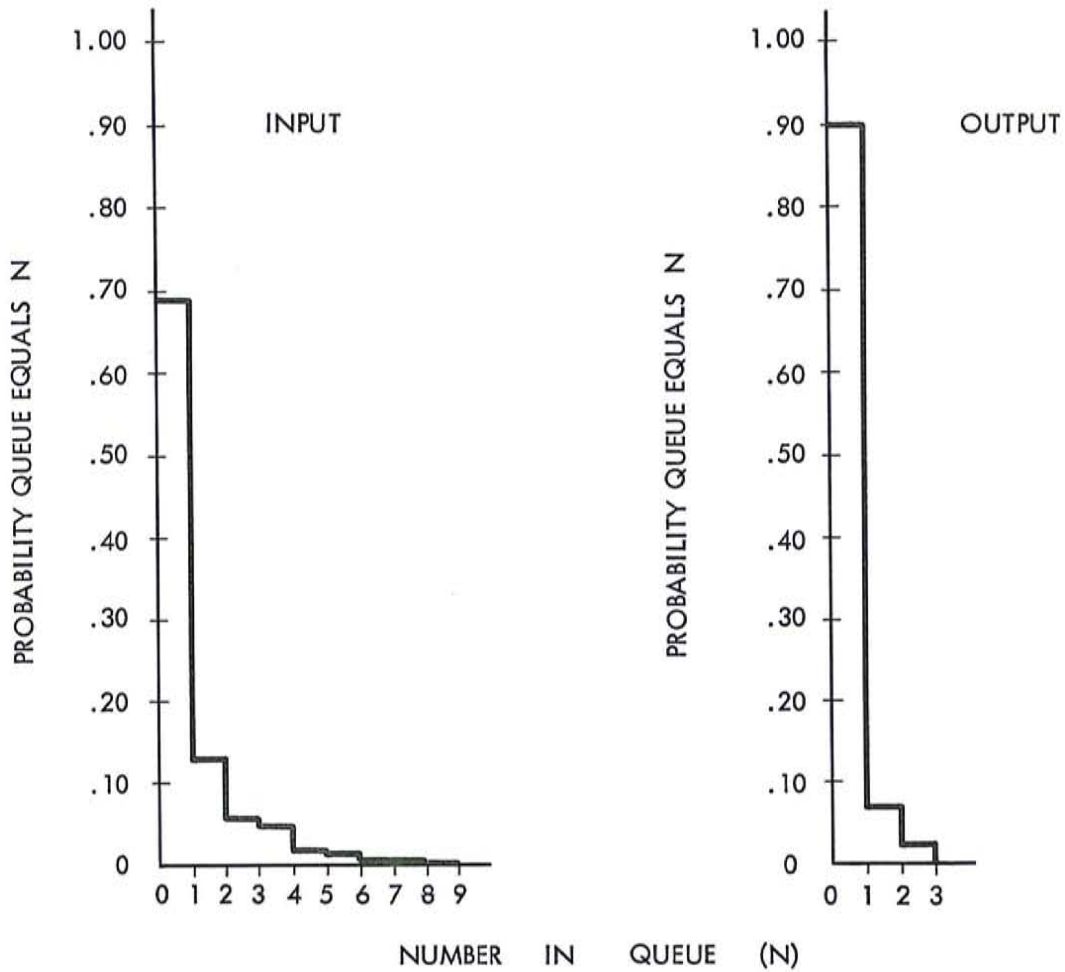

FIGURE 6-31

Figure 6-32 - Message Length Curve, Dallas Street, El Paso

Message length distribution is the tabulation of the actual message lengths simulated for Dallas Street, El Paso. These are similar to message lengths for the total Southern Pacific System described previously, but differ by reason of the particular characteristics of the location.

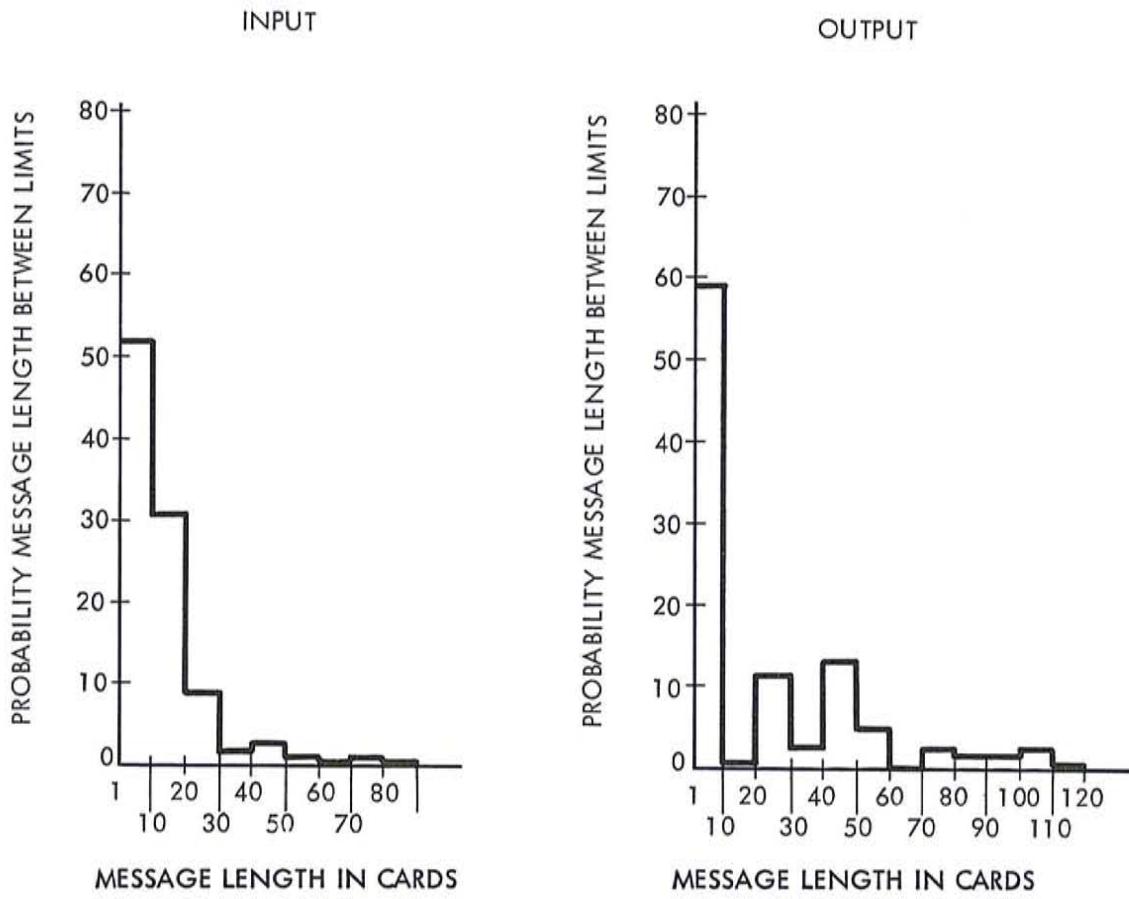

FIGURE 6-32

102717314

Southern Pacific Company

TABLE OF CONTENTS
EQUIPMENT SPECIFICATIONS

| | Page |
|---|------|
| EQUIPMENT COMPONENTS | 7-1 |
| CENTRAL PROCESSOR | 7-1 |
| IBM 7074 Data Processing System | 7-1 |
| IBM 1301 Disk Storage Unit and 7631 File Control Unit | 7-3 |
| IBM 7750 Programmed Transmission Control | 7-4 |
| Modifications to the IBM 7074 | 7-6 |
| Modifications to the IBM 1301 and 7631 | 7-7 |
| Modifications to the IBM 7750 | 7-7 |
| REGIONAL PROCESSING EQUIPMENT | 7-8 |
| IBM 1401 Data Processing System | 7-8 |
| EQUIPMENT LISTS | 7-11 |
| INPUT-OUTPUT UNITS | 7-14 |
| Configuration | 7-15 |
| Card Reader and Transmission Set | 7-21 |
| IBM 1912 Telegraphic Card Read-Punch | 7-22 |
| I/O UNIT LOCATION LISTING | 7-28 |

LIST OF ILLUSTRATIONS

| Figure | | Page |
|--------|--|------|
| 7-1 | IBM 1301 Disk Storage Unit | 7-3 |
| 7-2 | IBM 7631 File Control Unit | 7-4 |
| 7-3 | Functions of the IBM 7750 | 7-5 |
| 7-4 | IBM 1009 Data Transmission Unit | 7-9 |
| 7-5 | IBM 7702 Magnetic Tape Transmission Unit | 7-10 |
| 7-6 | Accounting I/O Unit Configuration (Config. #4) | 7-16 |
| 7-7 | Operating I/O Unit Configuration (Config. #3) | 7-18 |
| 7-8 | Freight Traffic, Dispatcher and Car Distributor I/O Unit Configuration (Config. #1) | 7-20 |
| 7-9 | IBM 1001 Data Transmission System | 7-22 |
| 7-10 | Configuration of Combined I/O Unit for Operating and Waybilling Applications (Config. #2) | 7-23 |
| 7-11 | Configuration of Multi-I/O Unit for Train Service Bureaus and Car Distributors (Config. #1-A) | 7-24 |
| 7-12 | Configuration of I/O Unit for Off-Line Traffic Offices (Config. #5) | 7-24 |
| 7-13 | I/O Unit Assignments by Location and Type (Pacific Lines) | 7-25 |
| 7-14 | I/O Unit Assignments by Location and Type (Texas and Louisiana Lines) | 7-26 |
| 7-15 | Off-Line I/O Unit Locations | 7-27 |

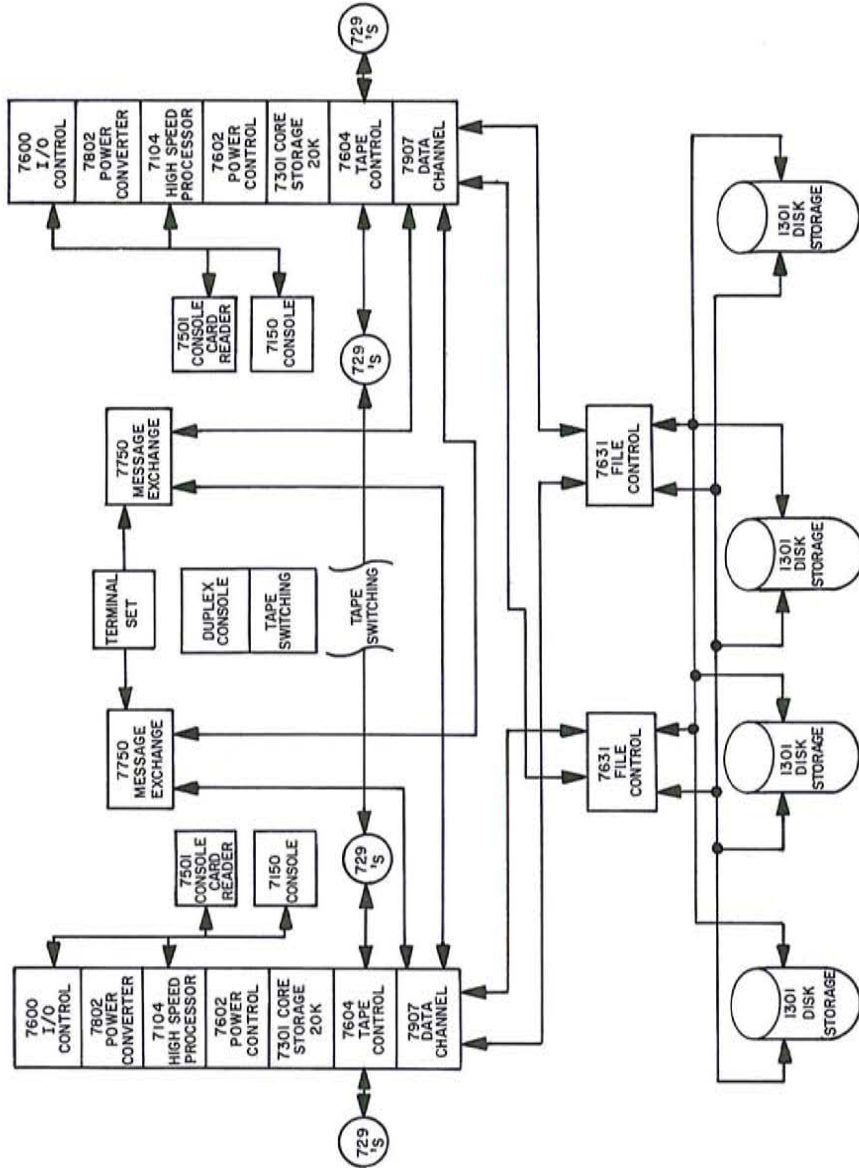

CENTRAL PROCESSOR FOR THE TOPS SYSTEM

EQUIPMENT SPECIFICATIONS

EQUIPMENT COMPONENTS

The IBM TELE-PROCESSING System designed for the Southern Pacific Company is capable of performing the functions of data transmission and data processing efficiently, rapidly, and reliably. The suggested equipment configuration will provide a system for the Southern Pacific Company with flexibility to meet varying requirements.

The equipment in the TELE-PROCESSING System is separated into three functional areas: a central processor, remote input-output (I/O) units, and associated processing equipment in regional locations. The equipment in each location performs its specific functions as part of the over-all system. The central data processor is functionally connected to the remote equipment through a communications network to form a system capable of performing all necessary data processing functions.

CENTRAL PROCESSOR

The central processor will handle the data processing and message switching functions of the TOPS System. Communications are entered into the central processor over transmission lines and are processed or routed to the proper location. Processed transactions containing required information are returned to appropriate I/O units when required.

The central processor consists of the IBM 7074 Data Processing System, IBM 1301 Disk Storage Units, IBM 7631 File Control Unit, IBM 7750 Programmed Transmission Control, and IBM 729 Magnetic Tape Units.

The Southern Pacific Company has an IBM 7074 installed in San Francisco. This IBM 7074 will be duplexed with another IBM 7074 to provide a standby for the TELE-PROCESSING System. This will insure continuous operation for the central processing unit during any period of emergency and during non-peak hours when preventive maintenance requirements are being fulfilled. At other times, the present IBM 7074 system will continue its normal function with an additional advantage of having access to the disk storage units of the TELE-PROCESSING System if this procedure is desirable for specific applications.

IBM 7074 Data Processing System

The IBM 7074 Data Processing System incorporates the most recent developments in high speed, solid-state technology. Features such as automatic priority processing and code validity checking provide the high degree of equipment availability necessary for proper utilization of the IBM 7074 in a TELE-PROCESSING System.

The IBM 7074 obtains an instruction or data word from core storage in four microseconds. This high internal speed allows simultaneous operation of the central processor with several input-output (I/O) data channels. The use of automatic priority

processing makes it possible to combine the supervisory program with priority routines for handling information flow for tape units, disk storage units, and data transmission input and output.

Priority processing allows the program execution to function normally until a peripheral unit has completed an operation. At this time, the application program is interrupted to service the unit requiring attention. As soon as the service is complete, the application program is resumed.

The central processor will be modified to allow an equipment malfunction to automatically initiate an interrupt of the supervisory program through priority processing. Priority routines can provide for diagnostic interrogation of the error indicators to determine the source of the error and the necessary corrective procedures. The units of the IBM 7074 system and their functions are:

- The IBM 7074 High Speed Processor, which contains the circuits used to perform arithmetic, logical and other programming operations for the IBM 7074.
- The IBM 7150 Console, which contains the main operating controls for the IBM 7074 and permits program operation, program initiation, and manual control of all instructions. The Customer Engineering console contains controls and indicators used in maintaining the system and in locating and correcting malfunctions.
- The IBM 7301 Core Storage is a high speed core storage containing words of program storage and data storage.
- The IBM 7501 Console Card Reader provides direct punched card input to the system under control of the stored program.
- The IBM 7600 Input-Output Control contains synchronizing and timing controls for peripheral equipment.
- The IBM 7602 Core Storage Control contains power controls for the system.
- The IBM 729 Tape Unit provides data or program storage on magnetic tape. The tape unit can read from, or write on, the tape at two densities of bit storage, either 556 or 220 characters per inch. The density is set by program control. The characters are read from, or written on, the tape at a speed of 15,000 or 41,700 characters per second. The reading and writing mechanism for the tape unit is contained in one unit called the two-gap head. The two-gap head contains a write head followed by a read head. Reading operations use the read head only, while writing operations use both heads. During writing, the write head records the data while the read head checks the character for validity.
- The IBM 7604 Tape Control Unit contains circuits for controlling and checking the transfer of data between core storage and the tape units. The control unit provides extensive checking for character validity during writing and reading. In addition to checking each character for validity, provision is made to check each record for validity.

- The IBM 7802 Power Converter converts 60 cycle power to 400 cycle power and isolates the central processor from the outside power source.
- The IBM 7907 Data Channel controls and synchronizes the transfer of data between core storage and disk storage units, and between core storage and the IBM 7750 Programmed Transmission Control. The IBM 7907 used in the TOPS System contains three channels. Each of the three channels operates independently of the other channels. One IBM 7907 Data Channel is used with each IBM 7074 system. Selection and priority scheduling of the data channels are controlled by the system.

IBM 1301 Disk Storage Unit and 7631 File Control Unit

The IBM 1301 Disk Storage Unit, shown in Figure 7-1, provides a large random access storage area. Each IBM 1301 contains two modules of disks and contains an access mechanism for each module. A storage capacity of up to 56,000,000 characters is provided by each IBM 1301. The data is accessed on the disks at a speed of 50-180 milliseconds and is transferred at a speed of 90,000 characters per second.

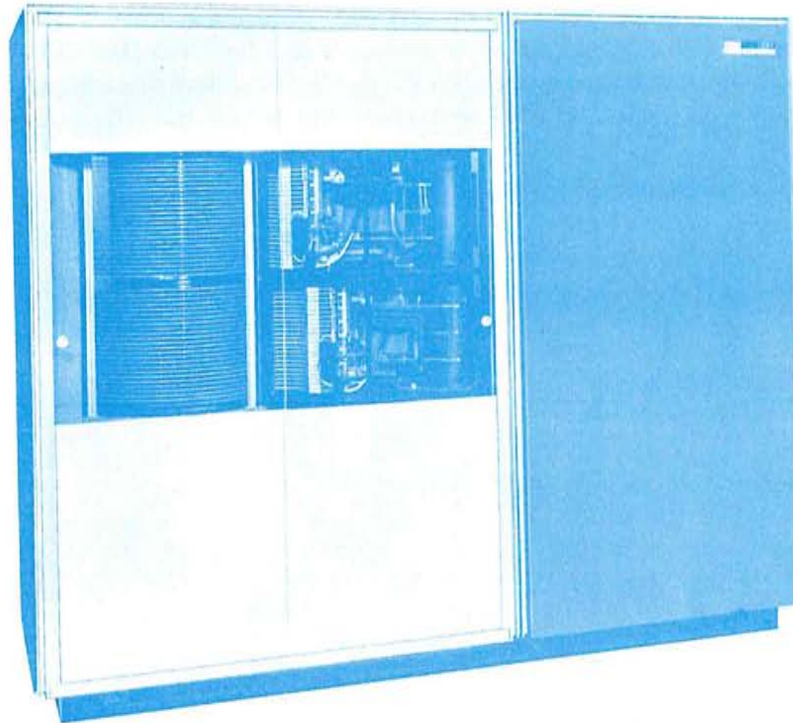

FIGURE 7-1 IBM 1301 DISK STORAGE UNIT

There are 250 tracks on each of 40 disk storage surfaces which provide 10,000 addressable data tracks in each module. Each disk surface has its individual read-write head. These heads are mounted on movable arms which position the head at the desired track.

A new IBM 7074 instruction, "Channel Select", initiates all IBM 1301 disk operations. The instruction performs three basic functions: (1) it selects the input-output channel and the file control to which the channel is connected; (2) it supplies

the address of the initial channel command that is to be sent to the IBM 9707 Data Channel; and (3) it forms and stores an initial status word which allows the program to later identify the operation in progress. When these basic functions are completed, the IBM 7074 proceeds to execute the instruction that follows the select instruction.

In this manner the disk storage unit may be signaled to position the access mechanism for reading and writing. During the "seek" time, the IBM 7074 may proceed with program execution.

After the access mechanism has been positioned, the disk storage unit will signal for attention. At this time, the IBM 7074 may again give the disk storage unit new instructions for reading or writing, or other orders.

Both access mechanisms may be given instructions to "seek" simultaneously. The IBM 7074 will proceed with its computation during the seek time, returning its attention to any disk storage unit only after the access mechanism is in position for reading or writing.

The central processor contains 2 IBM 7631 File Control Units (Figure 7-2). One channel of each IBM 7631 is connected to one of the duplexed IBM 7074's and the other channel is connected to the other IBM 7074. This method allows rapid switchover of equipment and allows each IBM 7074 to have access to any file which is not in use.



FIGURE 7-2 IBM 7631 FILE CONTROL UNIT

The IBM 7750 Programmed Transmission Control

The IBM 7750 Programmed Transmission Control is a stored program input-output device used for coupling a central processing unit to a communication network.

The unit receives binary electrical signals from a number of communication lines simultaneously; it converts the signals to bits and the bits to characters, and assembles the characters into messages. Code conversion, editing, and error checking are performed. The completed message may be relayed to the central processor or to an I/O unit. Figure 7-3 illustrates the functions of the IBM 7750.

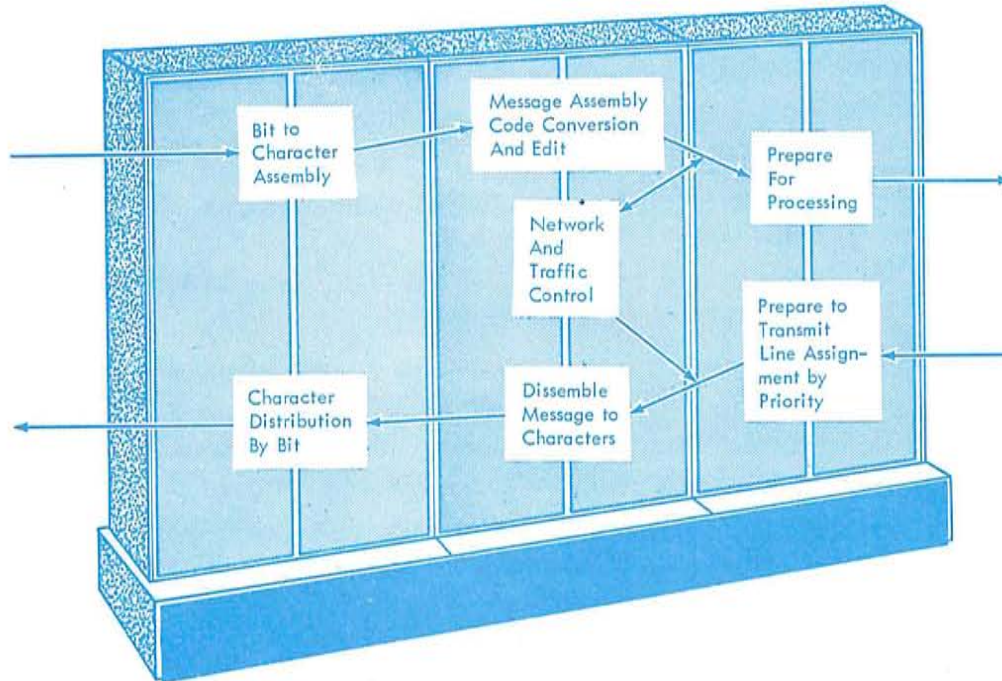

FIGURE 7-3 FUNCTIONS OF THE IBM 7750

An outgoing message from the central processor will be edited, code converted and error checked by the IBM 7750 and then transmitted to a communication line. Incoming messages are transmitted by the I/O units to the IBM 7750 where editing, code conversion and error checking is accomplished before the message is relayed to the central processor.

The IBM 7750 has two internal core storage units, the process storage and the control storage. Control storage provides 128 words of 48 bits each. Control storage performs alternate scan and process cycles to:

1. Service a channel in transferring data to or from the channel.
2. Provide an operational register for the execution of instructions.

The process storage will contain 16,384 words of 48 bits each. Programs, tables, and messages are stored in this area. This storage alternately locates and executes instructions.

The IBM 7750 includes multiplexing channel adapters that contain the transmission facilities. Up to 112 low speed transmission circuits may be attached to these units.

The IBM 7750 handles normal traffic and special conditions through a priority system. There are six levels of priority; these are called modes. Each mode handles a particular set of conditions.

If a special condition arises, the IBM 7750 automatically switches to the priority mode called for, provided it is a higher level than one in which the unit is operating. If two different modes are requested simultaneously, the IBM 7750 will switch automatically to the one with higher priority.

The IBM 7750 operates in the following modes:

1. Service Mode - This program contains error identification and recovery procedures.
2. Channel Service Mode - This program assigns a new storage block to the channel that requests it.
3. Copy Mode - This mode controls the transfer of data between the processor and the IBM 7750.
4. Out Mode - This program sets up control for the transfer of data from the IBM 7750 to the processor.
5. In Mode - This program sets up control for a transfer of data from the processor to the IBM 7750.
6. Normal Mode - Programs for code conversion, message editing, and other normal functions are carried out in this mode. If no other mode is requested, the IBM 7750 operates in the normal mode.

In addition to the above equipment, a Duplex Console will be provided for monitoring and controlling the active equipment. This unit contains the controls and alarms necessary to permit the rapid transfer of the TELE-PROCESSING System work load from one central processor to the other.

An I/O unit will also be located in the processing center for communication with the central processor and remote I/O units.

Modifications to Standard IBM Data Processing Units

The Southern Pacific Company TELE-PROCESSING System will consist of standard IBM units as previously described. However, these standard IBM units will require certain modifications in order to most efficiently handle the specific TOPS applications.

Modifications to the IBM 7074 Data Processing System

1. Real Time Clock and Real Time Clock Stacking Latch - The TELE-PROCESSING System must know the time of day to properly identify data and to automatically initiate the preparation of periodic reports. The real time clock will serve this function. A record of the time of day in hours and minutes will be maintained in the IBM 7301 Core Storage Unit.

2. Program Addressable Latch - The central processor will be required to signal the Duplex Console every few seconds that operation is proceeding normally. If this assurance is not received from the central processor, an alarm will be sounded so that the operator may take corrective action. The Program Addressable Latch provides this facility.
3. Diagnostic Stacking Latch and Interrupt Indicator - This modification provides for initiation of an automatic interrupt of the supervisory program if any error is detected through the Program Addressable Latch. Corrective action may then be taken. The IBM 7074 may operate in this diagnostic mode or may operate in the standard "stop on error" mode for normal data processing. The choice of mode will be made by the system operator by means of a switch on the IBM 7150 Console. An indicator will be provided on the Duplex Console to show the mode of operation.
4. Remote Emergency Off Switch - This is a safety feature to allow power for the IBM 7074 system to be turned off from the Duplex Console.

Modifications to IBM 1301 Disk Storage Units and IBM 7631 File Control Units

1. Cross Channel Switching - One of the requirements of the Southern Pacific Company System is that both IBM 7631 units have access to any disk storage module. The Cross Channel Switching modification will provide this facility.
2. Access Inoperative - If a malfunction occurs in a disk storage unit, the supervisory program may deactivate the particular module. This modification provides an indication to the Duplex Console that the module has been taken out of service by the program.
3. Independent Power Control - This modification makes power control of each IBM 1301 Disk Storage Unit independent of the IBM 7631 File Control Unit. If power must be removed from either IBM 7631 File Control Unit, the IBM 1301 Disk Storage Units may continue to operate through the second IBM 7631 File Control Unit.

Modifications to IBM 7750 Programmed Transmission Control

1. Dual Processor Interface - Allows an IBM 7750 Programmed Transmission Control to communicate with either IBM 7074 Data Processing System.
2. Duplex Low Speed Line Groups - Allows either IBM 7750 Programmed Transmission Control to operate with any or all communication lines. The Dual Processor Interface and Duplex Low Speed Line Group modifications provide duplexing facilities for the IBM 7750 Programmed Transmission Control.

3. Op Code, External Signal - Operation codes will be provided for the IBM 7750 Programmed Transmission Control programs. They will be used for sounding an alarm at the Duplex Console if trouble should occur in the IBM 7750 operation.

REGIONAL PROCESSING EQUIPMENT

At four locations (San Francisco, Portland, Los Angeles, and Houston), an IBM 1401 system will prepare freight bills, handle cash applications, and prepare special reports such as those for Car Distributors. The IBM 1401 provides the logical ability and the high speed necessary for this purpose.

The IBM 1401 system consists of an IBM 1401 Processing Unit, an IBM 1403 Printer, an IBM 1402 Card Read Punch, four IBM 729 or 7330 Magnetic Tape Units, and an IBM 1009 Data Transmission Unit. An IBM 7702 Tape Transmission Unit will be located at the central processor for data transmission to the remote locations.

Because the Southern Pacific Company has IBM 1401's installed at San Francisco and Houston, only slight additions will be required for these locations; an IBM 1009 Data Transmission Unit will be added at Houston.

The IBM 1401 Data Processing System

The IBM 1401 Processing Unit

The IBM 1401 contains the magnetic core storage and circuits that perform all machine logic. The IBM 1401, Model E-3, provides storage for 4,000 alphanumeric characters. The program instructions and data are stored. The IBM 1401 uses the variable word length concept. Each character position is addressable. Using this concept, each word occupies only the number of character positions needed for each instruction or data. This facility contributes to the high efficiency of the IBM 1401 Processing Unit.

The IBM 1402 Card Read-Punch

The IBM 1402 provides simultaneous card input and output. There are two card feeds: the read section has a rated speed of 800 cards per minute; the rated speed of the punch section is 250 cards per minute.

The IBM 1403 Printer

The IBM 1403 Printer provides printed output at the rate of 600 lines per minute. The printing mechanism consists of a mechanically-moving chain on which alphabetic, numeric and special characters are positioned. Printing is accomplished by proper positioning of a character on the chain opposite a magnet-driven hammer which presses the form against the chain.

The decoding of the input characters allows the mechanical positioning and timing of the chain opposite the hammer during the printing cycle. Each character is checked against the corresponding position in storage before printing occurs.

The IBM 1009 Data Transmission Unit

The IBM 1009 Data Transmission Unit, shown in Figure 7-4, permits two-way communication between the IBM 7702 Magnetic Tape Transmission Unit and the IBM 1401 system. The IBM 1009 controls the movement of data, one character at a time, from the storage area of the IBM 1401 to the transmission lines, or in the reverse direction. Characters may be transmitted at the rates of 75, 150 or up to 300 characters per second. Each character is checked for validity as it is received.



FIGURE 7-4 IBM 1009 DATA TRANSMISSION UNIT

The IBM 7702 Magnetic Tape Transmission Unit

The IBM 7702 Magnetic Tape Transmission Unit, shown in Figure 7-5, transmits and receives data from magnetic tape at 150, 250, or 300 characters per second over communication lines to or from the 1401 systems at Portland, Houston, and Los Angeles. The IBM 7702 checks reading, writing, and transmission to ensure accuracy.



FIGURE 7-5 IBM 7702 MAGNETIC TAPE TRANSMISSION UNIT

EQUIPMENT LISTS

The following lists outline the central processor equipment which will be used in the TOPS System. System A represents the new equipment necessary for TOPS; this equipment will be located in San Francisco. System B represents modifications that will be necessary to the IBM 7074 presently located in San Francisco. The regional processing equipment will be located in Portland, Los Angeles, Houston and San Francisco, as noted in the list.

SYSTEM EQUIPMENT (CENTRAL PROCESSOR)

SYSTEM A

| Unit | Model/S. F. Number | | Quantity |
|------|-----------------------|---------------------------------|----------|
| 7604 | I | Tape Control Unit | 1 |
| | | Special Feature: | |
| | 1019 | Additional Storage | 1 |
| 7501 | I | Console Card Reader | 1 |
| 7600 | II | I/O Control | 1 |
| | | Special Features: | |
| | 1018 | Additional Storage | 1 |
| | 2265 | Attach 7501 | 1 |
| 7602 | VI | Core Control | 1 |
| 7301 | 41 | Core Storage | 1 |
| 7301 | 42 | Core Storage | 1 |
| 7150 | I | Console | 1 |
| 7104 | III | High Speed Processor | 1 |
| | | Special Features: | |
| | 1017 | Additional Storage | 1 |
| | 3221 | Attach 7907 | 1 |
| | 7835 | Attach 10-729's to Channel I | 1 |
| | | Program Addressable Latch | 1 |
| | | RTC Stacking Latch | 1 |
| | | Real Time Clock | 1 |
| | | Remote Emergency Off Outlet | 1 |
| | | Diagnostic Stacking Latch | 1 |
| | | Interrupt Indicator | 1 |
| 7802 | I | Power Converter | 1 |
| 729 | II | Magnetic Tape Unit | 12 |
| | | Special Feature: | |
| | 7830 | Tape Switching | 8 |
| 7631 | IV | File Control Unit | 2 |
| | | Special Feature: | |
| | | Cross Channel Switching | 2 |
| 7750 | 3 | Programmed Transmission Control | 2 |
| | | Special Features: | |
| | 4860 | Low Speed Base | 2 |
| | 4861 | Low Speed Line Group | 8 |
| | 4862 | Low Speed Line Adapter Set | 56 |
| | 7890 | Telegraph Converter Base | 2 |
| | 7892 | Telegraph Converter Set | 2 |
| | 9442 | Low Speed Line Bit Rate | 2 |

| Unit | Model/S. F. Number | | Quantity |
|------|-----------------------|--|-----------------|
| 7750 | | Special Features: | |
| | | Duplex 2 Low Speed Line Groups - Relay | (For 8 Lines) |
| | | Dual Computer Interface | 2 |
| | | Op Code, External Signal | 2 |
| | | Inhibit/Enable Service Mode | 2 |
| | | Bit Rate Option | 2 |
| | | Duplex Low Speed Line Groups - Transistor Level | (For 104 Lines) |
| | | 7750 - Subset Compatability | 2 |
| 7907 | III | Data Channel | 1 |
| | | Special Feature: | |
| | | Data Channel Switch | 1 |
| | | Duplex Console | 1 |
| 1301 | II | Disk Storage Unit (1-1) | 4 |
| | | Special Features: | |
| | | Access Inoperative | 4 |
| | | Emergency Off Transformer | 4 |
| | | Cross Channel Switching | 4 |
| | | Independent Power Control | 4 |
| | | Input-Output Unit | 1 |

SYSTEM B

| Unit | Model/S. F. Number | | Quantity |
|--------|-----------------------|-----------------------------|----------|
| 7301 | 41 | Core Storage | 1* |
| 7301 | 42 | Core Storage | 1 |
| 7907 | III | Data Channel | 1 |
| | | Special Feature: | |
| | 3224 | Data Channel Switch | 1 |
| | | Special Features: | |
| (7604) | 1019 | Additional Storage | 1 |
| (7600) | 1018 | Additional Storage | 1 |
| (7104) | 1017 | Additional Storage | 1 |
| | 3221 | Attach 7907 | 1 |
| (7104) | | Program Addressable Latch | 1 |
| | | RTC Stacking Latch | 1 |
| | | Real Time Clock | 1 |
| | | Remote Emergency Off Outlet | 1 |
| | | Diagnostic Stacking Latch | 1 |
| | | Interrupt Indicator | 1 |

*This replaces a 7301, Model 4 now installed in San Francisco.

Southern Pacific Company

EQUIPMENT LIST (REGIONAL LOCATIONS)

| Unit | Model/S. F. Number | | Quantity |
|------|-----------------------|--|----------|
| 1009 | I | Data Transmission Unit (1 at Portland, Los Angeles and Houston) | 3 |
| 1401 | E-3 | Processing Unit (1 at Portland and Los Angeles) | 2 |
| | | Special Features: | |
| | 7080 | Serial I/O Adapter (1 for Houston field installed, 1 for Portland and Los Angeles Plant installed) | 3 |
| | 4575 | Hi-Lo-Eq. Compare | 2 |
| | 3835 | Expanded Print Edit | 2 |
| | 6040 | Read Punch Release | 2 |
| | 7600 | Sense Switches | 2 |
| | 5540 | Additional Print Control | 2 |
| 1403 | II | Printer | 2 |
| 1402 | I | Card Read-Punch (1 each of above for Portland and Los Angeles) | 2 |
| 7702 | I | Magnetic Tape Transmission Terminal (at San Francisco) | 1 |
| 7330 | I | Magnetic Tape Unit (4 at Portland, 4 at Los Angeles) | 8 |

INPUT-OUTPUT UNITS

The predominant characteristic of any TELE-PROCESSING System is its ability to transmit and receive data over communications lines. In order to accomplish this task with the required speed and accuracy, new equipment has been developed.

Input-output (I/O) units that monitor the flow of data over communications lines and control the various components for local operations will be installed at locations remote from the central processor. These I/O units have been modified to meet the functional specifications required for the TOPS System.

The I/O units to be used in the TOPS System will have the ability to operate in both the communications and local modes. The definition of the communications mode is that all data transferred between the components in the I/O unit is also transferred to the transmission line for entry into the central processor. Local mode is that data transferred between various components of the I/O unit, but not to the communication line.

The ability to operate simultaneously in both the communications and local modes is available in the various I/O units by means of two independent data channels for the flow of information. All components in an I/O unit can be selected for operation on either of these two channels by means of switches located on the operator's console; each component (i. e. printer, card reader, etc. ,) has its own switch. It is not possible for any component to operate on both channels at the same time. The operator places the required component on the proper channel to perform a given task by means of the toggle switches at his console.

The rate of data transfer on each of the two channels is 14.8 characters per second for all components.

In the operation of the I/O unit in the communications mode, transmission from the I/O unit to the central processor is under control of the IBM 7750 Programmed Transmission Control. The IBM 7750 will continuously scan each I/O unit for input information for the central processor. If the I/O unit does not have information to transmit, a "no data" character will be automatically transmitted by the I/O unit to the IBM 7750. If the I/O unit has information to send, the first character of the message will be transmitted.

Positive acknowledgement of the input status of the I/O unit is always received by the IBM 7750. If a no message indication has been received, the IBM 7750 will continue in its scanning cycle to the next input I/O unit. The process, as described above, will then repeat itself. This method of IBM 7750 scanning is commonly referred to as "Polling".

The only exception to a continuous polling scan will occur when the IBM 7750 has an output message for an I/O unit. In this instance, the IBM 7750 will interrogate an I/O unit to determine if the required output component is available to receive the transmission. The I/O unit will automatically respond with a character indicating its receive status. If the required output component is not ready to receive, visual and audible indication will be triggered at the I/O unit to alert the operator to restore the required output component to the communications mode. This IBM 7750 mode of operation is called "Selection".

Southern Pacific Company

Configuration

All I/O unit configurations are modular. The interface between the I/O unit and the communications line is called the Terminal Control Unit (TCU) and is required in each configuration. The TCU controls the mode of operation of all components within the I/O unit configuration. The TCU also prepares data in the proper form for entry from the I/O unit input component to the communication network; the communication network requires that messages be transmitted in a serial by bit, serial by character form. This technique is commonly referred to as serializing data. The inverse is true when data is transmitted from the communications network to the TCU; this technique is known as de-serializing data.

All components are connected to the TCU which also contains all the operator control lights and switches for each component. The control lights and switches are all within easy access of the operator.

Separate configurations have been designed for each of the three application areas of the TOPS System: Accounting, Operating and Traffic.

Accounting I/O Units in Agencies and Junctions

The I/O unit in the accounting area is called the Waybilling and Transmission Set. Its primary function will be to produce a waybill on the standard printed forms currently used, and simultaneously produce the data printed in a paper tape for temporary storage before entry into the central processor. All movements of the form, both vertically and horizontally, will be encoded by the TCU so that an image of the waybill can be reconstructed in the central processor.

The configuration required in the Accounting Area will consist of the following components: (Figure 7-6)

1. TCU - This is the interface between the I/O unit and the communications network. It also contains all controls and power supply.
2. Keyboard - This device is used to enter all data to produce a printed copy and/or to punch data in the paper tape buffer. This keyboard does not require special shifts by the operator during waybill preparation. Each key depression is automatically encoded by a data translator to the required transmission code.
3. Printer - The printer used will be an IBM electric typewriter which will be modified by the addition of control switches and a special device mounted on the platen; this configuration will enable the recording of all platen index movements. A code will be produced for each index movement. Movement across the document line will be recorded by normal spaces and tabs. There will be no carriage movement in the printer; instead, the print mechanism will traverse across the document. A pin-feed forms guide will also be provided for document movement. The printer will provide up to five carbon copies and will also have the provision to accommodate a 13-inch writing line. During the preparation of the waybill, special check codes will be automatically produced by the printer and inserted in

the paper tape buffer after each return of the print mechanism to its home position on a new line. These codes will enable the IBM 7750 to periodically check the accuracy of the data transmission from the Waybilling and Transmission Set.

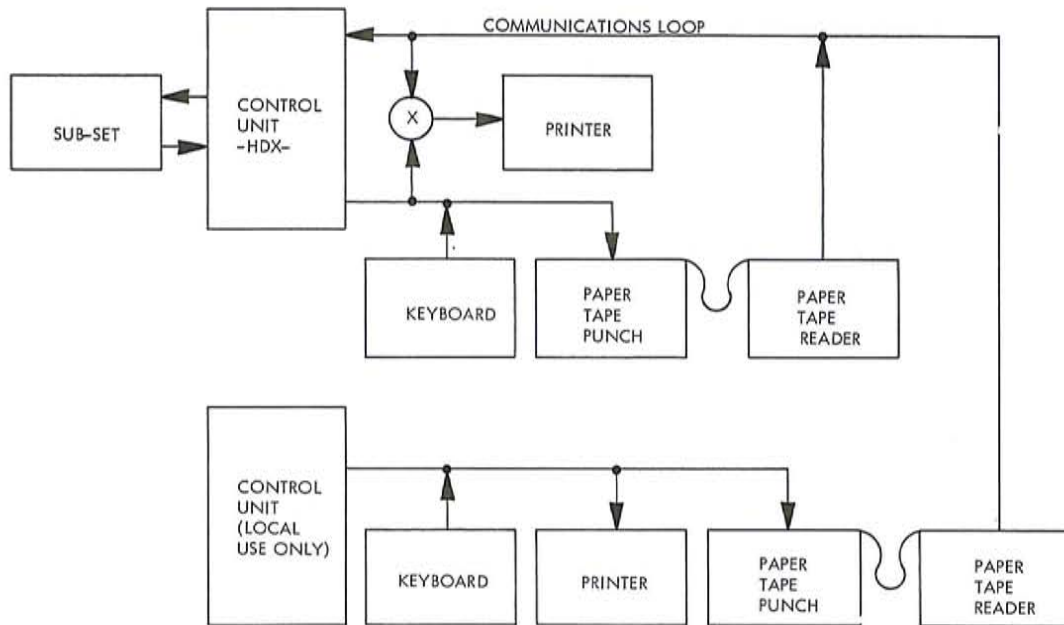

FIGURE 7-6 ACCOUNTING I/O UNIT CONFIGURATION (CONFIG. #4)

4. Paper Tape Punch - This component will produce a seven channel tape for all information to be stored temporarily before entry into the central processor. Six channels will be used for data, and the seventh channel will be used to indicate record blocks. The punching speed is 14.8 characters per second.
5. Paper Tape Reader - This component will read all paper tape to be transmitted to the central processor at a rate of 14.8 characters per second. A mechanism for automatic tape reversal for error check conditions will be provided. Information will be transmitted to the central processor in record blocks and will be checked for errors. In the event of an error indication, the tape record block in error will be automatically backed-up and retransmitted by the paper tape reader. The paper tape reader receives all its timing and control signals from the TCU.

To produce a waybill, the operator will not be required to alter or change any procedure that is currently used with waybill preparation. The waybill form will be typed in the usual manner with only these exceptions:

1. The operator must start typing in a special box in the upper left hand corner of the document in order to encode the form used, and trigger a code emitter on the printer to begin punching line indexes in paper

tape. This will also indicate to the central processor the start of the waybill preparation, and also the type of waybill. With a record of all line indexes, skips and tabs, the central processor will be able to reconstruct a matrix image of the waybill. The central processor will then remove all superfluous control characters.

2. The second requirement is that after all information is entered on the waybill, the typist will be required to insert a special end of message character (which will be available on the keyboard) at the bottom of the document. This will signify the end of the waybill and will turn off the code emitter in the printer.

During the waybill preparation, a punched paper tape will be produced as a by-product. The punched tape will be the temporary storage medium for the data to be subsequently entered into the central processor and will contain all index movements, tabs, spaces and waybill data. The waybill data will be transferred at a rate of 14.8 characters per second, via the paper tape reader, to the TCU. The TCU will then input the information in serial by bit, serial by character form to the communication line for entry into the central processor. As information is transmitted, checks will be made by the TCU and the central processor. After a message block of approximately one hundred characters, the information will be checked for transmission errors. If the information has been transmitted correctly, the next block will be transmitted. Whenever a check is made that indicates an incorrect transmission, the block on tape will be automatically backed-up by the tape reader and will be retransmitted. If the transmission error occurs three consecutive times, the central processor will send back to the I/O unit an indication signifying that error routines should be initiated. The operator will isolate the I/O unit from the communication equipment and determine if the trouble area is in his I/O unit, or in the communications equipment.

Operating I/O Units in Yards

The I/O unit configuration designed for the operating applications will use a punched card as the source document for both receiving and transmitting information. For each card transmitted or received at an I/O unit location, a log will be printed for record purposes. The speed of data transmission to and from the I/O unit will be 14.8 characters per second, and all cards produced either locally or by the central processor will also have the punched information printed across the top of the card. Card handling will be facilitated by this procedure.

The configuration of the operating I/O unit will include the following components: (Figure 7-7)

1. TCU - This is the interface between I/O unit and communications network; it also controls all internal I/O unit operations.
2. Card Reader - This component will read cards at a rate of 14.8 characters per second. A hopper and stacker will also be provided to permit entry of card packs, and their capacity will be 350 cards.

A card weight will not be required in the card feed hopper. Corner cut recognition will also be provided to ensure that cards are properly placed in the hopper. Improperly oriented cards will not be accepted. A program feature will be provided to enable high speed field skipping of information fields not to be transmitted. This feature will also provide high speed ejection of the card from the read station on any column desired. The desired column required for ejection will have to be pre-set in the control device. When transmitting data in the communications mode, automatic transmission checking will be provided by the card reader. When error conditions are encountered, the card will automatically re-cycle through the read station and retransmit the punched data. If a successful error-free transmission is not accomplished after three attempts, the IBM 7750 will output an indication to the I/O unit for an operator to isolate the reader from the communications line and initiate procedures to rectify the problem.

3. Card Punch - This component will be similar to an IBM 26 Card Punch and will produce cards at a rate of 14.8 columns per second when used with the TCU. When the punch is used in the local mode, information can be entered from the same standard keyboard used to transfer information to the printer.

When the card punch is used completely independent of the TCU, the standard IBM 26 keyboard will be used for the entry of information. This unit operates at a punching speed up to 18 characters per second.

If the card punch is being used for a local operation, and the central processor requests that the punch be made available to receive a message output, an audible alarm will alert the operator to restore it to the communication line.

4. Keyboard - The keyboard will operate in the local mode to transfer data to the card punch and/or printer. It will contain alphabetic, numeric, special and control characters. No case shifts will be required to enter numbers and letters.

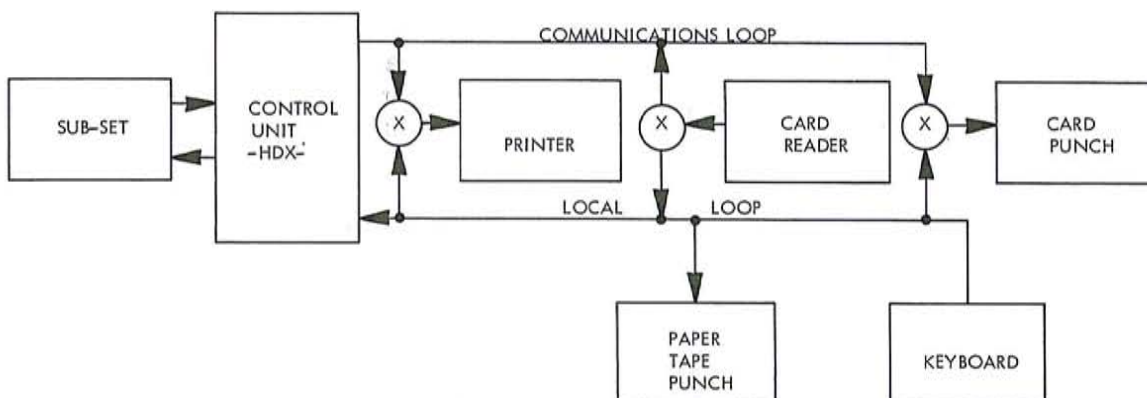

FIGURE 7-7 OPERATING I/O UNIT CONFIGURATION (CONFIG. #3)

5. Printer - This component is similar to the accounting I/O unit except that the code emitter will not be on the platen. The speed of operation of this unit will be 14.8 characters per second when under the control of the TCU.

The method of I/O unit operation in the operating configuration will be similar to that previously described. However, in the operating I/O unit the machine-readable document is the punched card.

Whenever information is to be transmitted to the central processor, cards specified in the operating procedures will be placed in the hopper of the card reader. If the service request button has not been previously activated to indicate to the central processor that data is ready for transmission, the operator will be required to push this button. The control of the reading of the cards will then be transferred to the IBM 7750 Programmed Transmission Control. The IBM 7750 will receive one card at a time, and will check each card to ensure a correct transmission. If a card has been incorrectly transmitted, it will be automatically re-cycled through the read station and the information will be re-entered.

If three transmission attempts for a card are unsuccessful, an alarm will be triggered at the I/O unit to notify the operator to investigate the trouble. If no errors are detected, the cards will pass through the read station until the End of Message (EOM) character is read from the trailer card. The trailer card always contains the EOM character and is always the last card of any group of cards constituting a message.

As cards are being read into the central processor, a log of each card will be produced on the printer. In the case where a card is incorrectly transmitted, the I/O unit will print an "off-set underscore" character at the end of the line to identify it as an incorrect message. The retransmission will be recorded on the next line.

When the I/O unit is receiving information from the central processor, the output will be a punched card and/or a printed copy of the transmission. Each card that is received by the I/O unit will be checked for error. If the card information has been incorrectly transmitted, and 11-punch will be emitted by the TCU and punched in column 81 of the card. On the printed page copy, an "off-set underscore" character will be printed to show that the line is incorrect. As with input, each card will be listed on a separate line on the printed page copy. The transmission will then be repeated and a new card will be punched and printed by the I/O unit. If three attempts are made without a successful transmission, an alarm will be triggered at the I/O unit to alert the operator.

All of the above mentioned units may also be used in a local operation.

To use the components in the local mode, the operator will select the required components by setting the switch associated with each component on the control panel to the "local loop" setting. If the local operation requires programming or format control, a source of the control characters will be provided. If the configuration is to be implemented for the operating applications, a program control device will be available on the card reader for all program functions.

Information read from the program control device will be transmitted to the TCU which will monitor the operation of the required components in the program operation.

The local operation will not prohibit any transmission to or from the central processor of I/O components not required in the local operation.

I/O Units in Freight Traffic, Dispatcher and Car Distributor Offices

The primary function of these I/O units is to permit the traffic offices to have rapid inquiry and response to available data in the central processor. In addition, this configuration will also be used for various messages specified in the operating procedures for the dispatchers and car distributors.

The I/O unit configuration for the on-line traffic offices, train dispatchers, train service bureaus and car distributors will consist of the following components: (Figure 7-8)

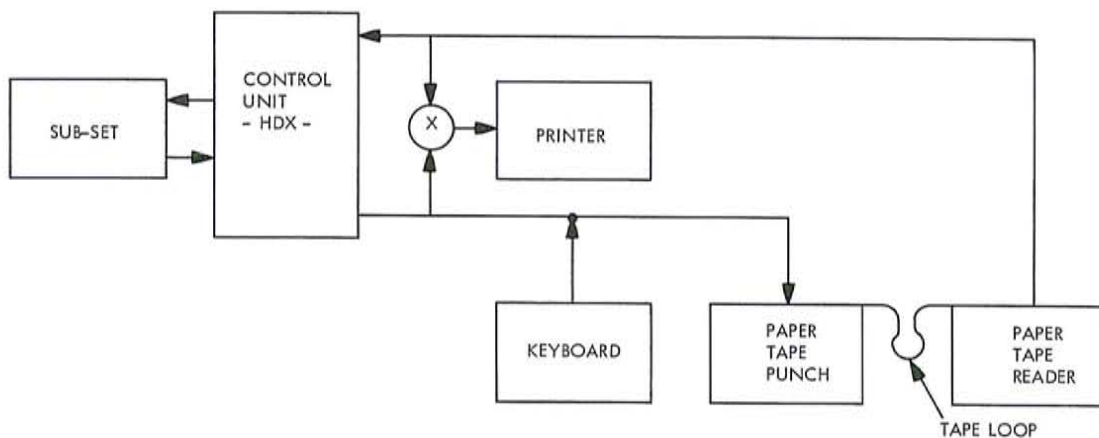

FIGURE 7-8 FREIGHT TRAFFIC, DISPATCHER AND CAR DISTRIBUTOR I/O UNIT CONFIGURATION (CONFIG. #1)

1. TCU - This is the interface between I/O unit and communications network; it also controls all internal terminal operations.
2. Keyboard - The keyboard will operate in the local mode to transfer data to the card punch and/or printer. It will contain alphabetic, numeric, special and control characters. No case shifts will be required to enter numbers and letters.
3. Printer - This component is similar to that described for the accounting I/O unit except that it will not be on the platen. The speed of operation of this unit will be 14.8 characters per second when under the control of the TCU.

4. Paper Tape Punch - This component will produce a seven-channel tape for all information to be stored temporarily before entry into the central processor. Six channels will be used for data, and the seventh channel will be used to indicate record blocks. The punching speed is 14.8 characters per second; feed and take-up reels will be provided.
5. Paper Tape Reader - This component will read all paper tape to be transmitted to the central processor at a rate of 14.8 characters per second. A feed and take-up reel will be provided, together with a mechanism of automatic tape reversal for error check conditions. Information will be retransmitted to the central processor in record blocks and will be checked for errors. In the event of an error indication, the tape record block in error will be automatically retransmitted by the paper tape reader. The paper tape reader receives all its timing and control signals from the TCU.

The speed of the I/O units will be 14.8 characters per second.

The operation of the I/O unit with the communications network will be under control of the IBM 7750. The local operation will be under operator control. Whenever an operator wishes to input data or request information in the form of an inquiry from the central processor, he will utilize the keyboard, printer and paper tape punch. He will use the keyboard for data entry and produce a printed copy of the input for verification purposes; he will also produce the information in punched paper tape. Upon completion of the message, the operator will request service from the central processor by pushing a button located on the TCU, making sure that the paper tape reader switch is set to the communications mode. If an answer is required for an inquiry made to the central processor, the operator will return the printer to the communications mode. If only one printer is available at the location, it will always be set in the communications mode when not in use in a local operation.

Card Reader and Transmission Set

The IBM 1001 Data Transmission System (See Figure 7-9) will be used as the card reader and transmission set described in the operating procedures. It consists of a card reader and keyboard that permits automatic transmission over the phone lines of fixed numeric data from 22 columns in an IBM card. Various control codes such as start and end of transmission will be entered through the keyboard.

The data is transmitted from an IBM 1001 to an IBM 26 card punch equipped with a data translator; the data translator converts the signals sent over the telephone circuits to the IBM punched card code for output.

Contact between the card reader transmission set and the receiving card punch is made by dialing the telephone number for the receiving location. An automatic connect-disconnect feature enables the call to be answered, and allows the card punch to accept data without operator attention. The IBM 1001 will send an audible tone when connection with the receiving punch has been made. The operator

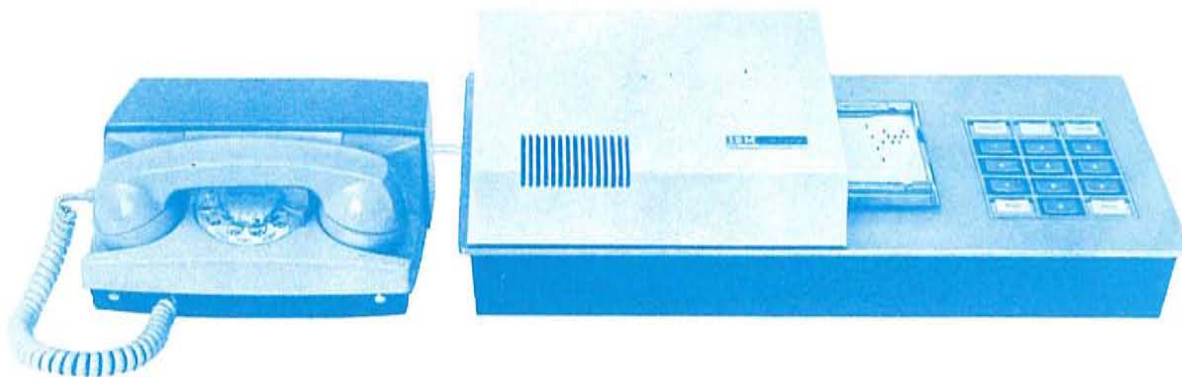

FIGURE 7-9 IBM 1001 DATA TRANSMISSION SYSTEM

will then insert a card in the reader which will serially read information from the card at a rate of up to 12 columns per second. The facsimile cards produced at the receiving punch will be entered into the card reader of an I/O unit for transmission to the central processor. When the punch indicates to the IBM 1001 that the message has been correctly received, the transmitting station will disconnect. The receiving card punch is then available to receive the next call.

IBM 1912 Telegraphic Card Reader-Punch

In certain situations within a yard complex, the operating procedures call for the transmission of cards and/or lists to points up to several miles from an I/O unit. These requirements are met with the IBM 1912 Telegraphic Card Reader and Punch which provides card input, card output, or a printed copy on a receiving printer.

The IBM 1912 is basically an IBM 26, Model 1, Printing Card Punch with added conversion devices and control circuitry to send or receive in the 5-channel telegraphic code. The IBM 1912, whether used for sending, receiving, or sending-receiving, can be used independently of the communication line as a standard card punch by operating a switch on the keyboard. When using the IBM 1912 as a receiving card punch, TELETYPE* codes may be transmitted to the unit at a constant rate of speed (6 to 10 characters per second) depending on the system used. A six character per second rate is equivalent to a 60 word per minute TELETYPE rate. However, for card punch functions such as skipping, duplication, and card release, it will be required that the codes initiating the function be followed by additional non-card punch codes to provide sufficient time to perform these functions.

When using the IBM 1912 as a card reader, the reading rate of the unit will be limited by the TELETYPE unit to which the reader is attached. The 26 alphabetic characters, 10 digits, and spaces in the cards will be automatically converted by a translator in the IBM 1912 to their equivalent TELETYPE codes. The translator unit will also accept seven special characters of the eleven normally available with an IBM 26.

*Trademark of the TELETYPE Corporation.

A patch panel is provided in the IBM 1912 to enable wiring of the special characters desired. The figures and letter-shift codes are automatically provided by the IBM 1912 translator whenever a character read calls for a shift change. Fields or columns on the card for which transmission is not desired may be programmed for skipping or releasing by means of the program card drum on the IBM 1912. The program feature may also be used to transmit Teletypewriter control codes such as CR (Carriage Return), LF (Line Feed), and LTRS (Letters-shift Codes). The first two codes activate the telegraphic printer carriage return and line feed functions, and the letters-shift codes (two in sequence) are used to provide time to release and feed a new card in performing card to card operations.

When used as a card punch connected to TELETYPE lines, the IBM 1912 will convert the transmitted TELETYPE data to the IBM card code for output in punched cards. All special telegraphic codes such as letter figure shift, CR, and LF will be prevented from causing an output by patch panel wiring. The card punch speed will vary, depending on the TELETYPE unit to which the IBM 1912 is connected.

Fields or columns can be duplicated or skipped under program card control. Data characters cannot be received while card punch functions are being performed.

When remote listing ability is required in the TOPS System, an IBM 1912 will be located at the nearest I/O unit and connected to a Teletypewriter at the remote point. If card output is also required, an IBM 1912 will be installed at the remote point, in addition to the Teletypewriter.

In addition to the I/O unit configurations shown in Figures 7-6, 7-7 and 7-8, three other I/O unit configurations will be used in the TOPS System. These are the combined I/O unit for Operating and Waybiling Applications, shown in Figure 7-10, the Multi-I/O Unit for Train Service Bureaus and Car Distributors, shown in Figure 7-11, and the I/O Unit for the Off-Line Traffic Offices, which is shown in Figure 7-12.

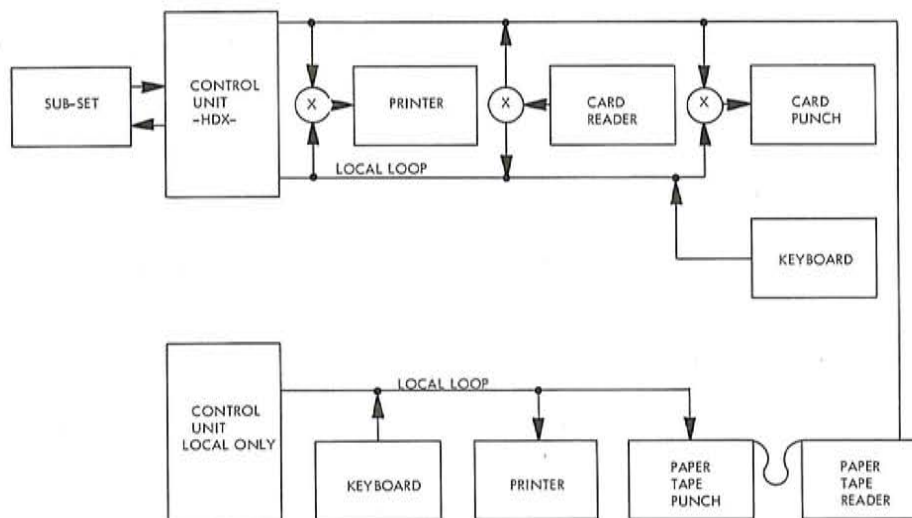

FIGURE 7-10 CONFIGURATION OF COMBINED I/O UNIT FOR OPERATING AND WAYBILLING APPLICATIONS (CONFIG. #2)

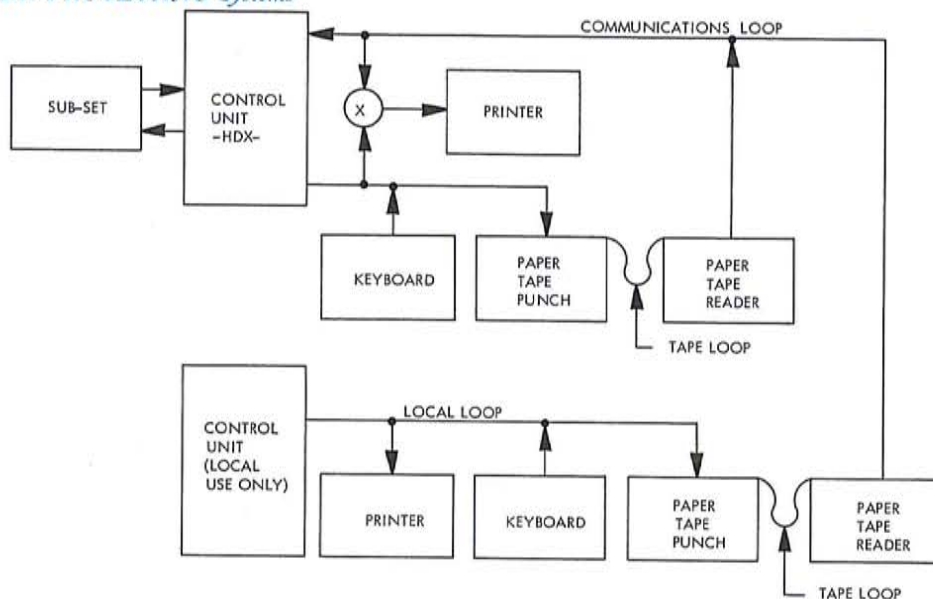

FIGURE 7-11 CONFIGURATION OF MULTI - I/O UNIT FOR TRAIN SERVICE BUREAUS AND CAR DISTRIBUTORS (CONFIG. #1-A)

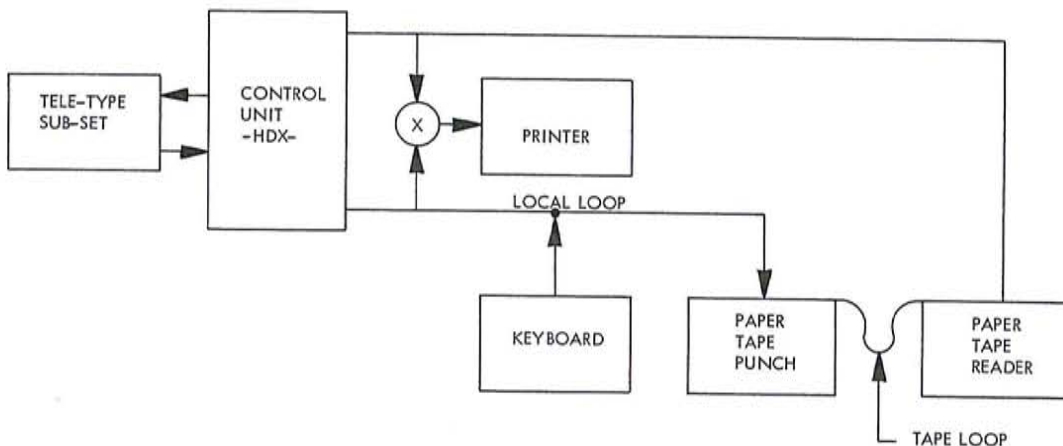

FIGURE 7-12 CONFIGURATION OF I/O UNIT FOR OFF-LINE TRAFFIC OFFICES (CONFIG. #5)

The foldout, Figure 7-13 and Figure 7-14 show the I/O Unit assignments by location and type for both the Pacific Lines and the Texas and Louisiana Lines. The locations of the I/O units are then presented in tabular form showing the configuration and each location and the number of each component.

The TELE-PROCESSING System specified here may be expanded on a building block basis as new technological advances are made and when new applications are included. For example, the IBM 7074 system may be expanded with additional core storage or with additional tape units. The IBM 7074 itself is of modular construction. One or more modules may be added or replaced should technological improvement make this step desirable. If new applications should require additional speed or storage, channel and disk storage capacity may be increased. If new I/O unit locations should be required, I/O units and communication lines may be added. Flexibility and capability for expansion are inherent parts of the entire TOPS System.

Southern Pacific Company

SOUTHERN PACIFIC COMPANY

PACIFIC LINES

INPUT-OUTPUT ASSIGNMENTS BY LOCATION AND TYPE

- PORTLAND I/O UNITS**
- NPT INTERCHANGE
 - BROOKLYN YARD-SE
 - BROOKLYN NORTH END
 - PORTLAND CAR DIST
 - PORTLAND TRAFFIC

- EUGENE I/O UNITS**
- WEST END
 - EAST END
 - YARD OFFICE
 - DISPATCHER
 - OLD YARD
 - TRAFFIC OFFICE

SAN FRANCISCO-OAKLAND AREA

DISPATCHER ● SAN RAFAEL ● RODEO MARTINEZ ● PORT CHICAGO ● PITTSBURG ● RICHMOND ● EMERYVILLE ● OAKLAND YARD ● EAST OAKLAND ● SAN FRANCISCO ● BAYSHORE ● CHEVROLET ● ELMHURST ● MULFORD ● HAYWARD ● SOUTH CITY ● EAST PLEASANTON ● NEWARK ● NILES ● REDWOOD JCT ● MILPITAS ● SUNNYVALE ● SAN JOSE ● DESERT HOMESTEAD ●

OTHER OAKLAND I/O UNITS

- TRAFFIC OFFICE
- DISPATCHER
- DESERT HOMESTEAD

SAN FRANCISCO I/O UNITS

- FREIGHT OFFICE
- FREIGHT TRAFFIC
- TRAIN SERVICE BUR
- RATING AND REV
- SYSTEM CAR DIST
- MISSION BAY
- DISPATCHER
- DIVER BUREAU
- REGIONAL CAR DIST

LOS ANGELES AND VICINITY

GEMCO ● HOLLYWOOD ● BALDWIN PARK ● SAN BERNADINO ● LOS ANGELES ● KAISER ● COLTON ● CULVER CITY ● TWEEDY ● LOS NIETOS ● CITY OF INDUSTRY ● RIVERSIDE ● EL SEGUNDO ● NORWALK ● ANAHEIM ● TORRANCE ● WATSON ● WILMINGTON ● LONG BEACH ● SANTA ANA ●

LOS ANGELES I/O UNITS

| | | |
|----------------|-------------------|---------------------|
| ● BULL RING | ● YARD OFFICE | ● DESK YARDMASTER |
| ● HUMP | ● GEN SHOPS | ● JCT RAILROAD |
| ● "C" | ● PEF | ● ATSF |
| ● UP | ● CAR DIST | ● TRAIN SERVICE BUR |
| ○ DISPATCHER | ○ L.A. HARBOR | ○ PE |
| ○ 8TH STREET | ○ P.E. DISPATCHER | ○ BUTTE STREET |
| ○ STATE STREET | ○ WINGFOOT | ○ GRAHAM |

- ROSEVILLE I/O UNITS**
- HUMP
 - YARD OFFICE
 - PFE
 - EAST END

- SACRAMENTO I/O UNITS**
- YARD OFFICE
 - TRAFFIC OFFICE
 - DISPATCHER

- BAKERSFIELD I/O UNITS**
- DISPATCHER
 - SUPT
 - FREIGHT AGENCY

- TUCSON I/O UNITS**
- AGENCY
 - TRAFFIC OFFICE
 - YARD OFFICE
 - 22ND STREET
 - PFE
 - DISPATCHER

- EL PASO I/O UNITS**
- DALLAS STREET
 - ADAIR
 - TRAFFIC OFFICE

LEGEND:

- OPERATING I/O UNITS ONLY
- ACCOUNTING I/O UNITS ONLY
- ACCOUNTING AND OPERATING I/O UNITS
- ACCOUNTING, OPERATING AND TRAFFIC I/O UNITS
- TRAFFIC, CAR DISTRIBUTOR AND DISPATCHER I/O UNITS
- ▲ MINOR I/O UNITS

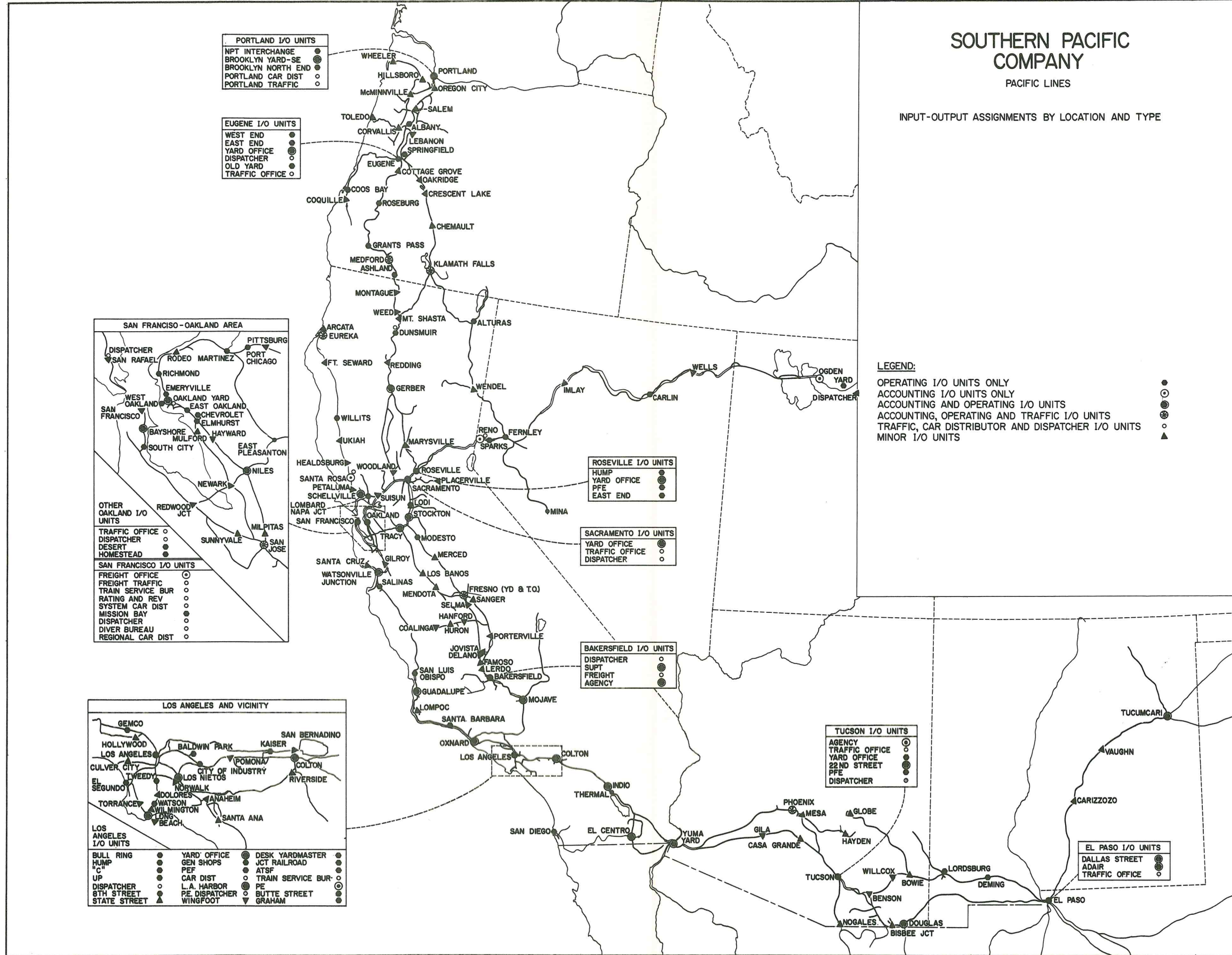

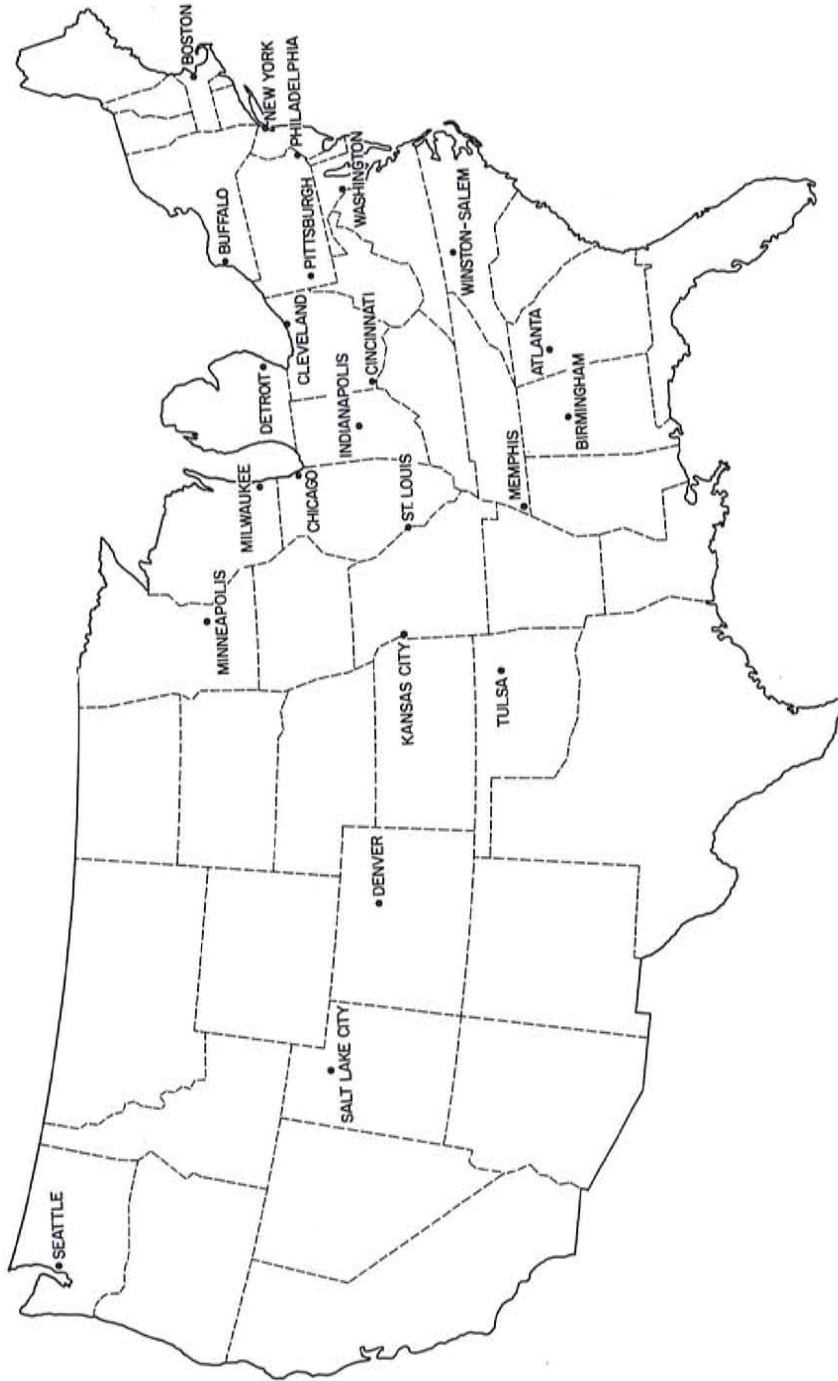

FIGURE 7-15 OFF-LINE I/O UNIT LOCATIONS

I/O UNIT LOCATIONS

The following listing shows the equipment configuration for the I/O unit locations in the TOPS System. The listing is given by division and includes the location, type of I/O unit configuration, and the type and number of individual units in the configuration.

PORTLAND DIVISION

| Location | Type | Config. No. | Control Units | Control Units (Local Use Only) | Printer | Platen Printer | | CR | CP | PTR | PTP | 1001 | 010 | 1912 |
|--------------------|----------------|-------------|---------------|--------------------------------|---------|----------------|----|----|----|-----|-----|------|-----|------|
| | | | | | | With Emmitter | KB | | | | | | | |
| NPT Interchange | OP. | 3 | 1 | | 1 | 1 | 1 | 1 | | | | | | |
| Portland Car Dist. | | A-1 | 4 | 2 | 4 | | 4 | | | 4 | | | | |
| Portland Traffic | Traffic | 1 | 1 | | 1 | | 1 | | | 1 | | | | |
| Brooklyn - YO | OP. | 3 | 2 | | 2 | | 2 | 2 | | | | | | |
| Brooklyn - YO | Acct. | 4 | 3 | 1 | | 3 | 3 | | | 3 | | | | |
| Brooklyn - North | OP. | 3 | 1 | | 1 | | 1 | 1 | | | | | | |
| | End | | | | | | | | | | | | | |
| Salem | OP. | 3 | 1 | | 1 | | 1 | 1 | | | | | | |
| Salem | Traffic | 1 | 1 | | 1 | | 1 | | | 1 | | | | |
| Albany | OP. | 3 | 1 | | 1 | | 1 | 1 | | | | | | |
| Eugene - West | Remote Listing | | | | | | | | | | | | | |
| Eugene - East | Remote Listing | | | | | | | | | | | | | |
| Eugene - East | End | | | | | | | | | | | | | |
| Eugene Yard Office | OP. | 3 | 2 | | 2 | | 2 | 2 | | | | | | 2 |
| Eugene Yard Office | Acct. | 4 | 5 | 2 | | 5 | 5 | | | 5 | | | | 5 |
| Eugene Dispatcher | OP. | 1 | 2 | | 2 | | 2 | | | 2 | | | | 2 |
| Eugene Old Yard | OP. | 3 | 1 | | 1 | | 1 | 1 | | | | | | 1 |

| Location | Type | Config. No. | Control Units | Control (Local Use Only) | Printer | Platen Printer | | | | | | | | | | | |
|-----------------------|------------|-------------|---------------|--------------------------|---------|----------------|----|----|----|-----|-----|------|-----|------|--|--|---|
| | | | | | | With Emitter | KB | CR | CP | PTR | PTP | 1001 | 010 | 1912 | | | |
| Eugene Traffic Office | Traffic | 1 | 1 | | 1 | | 1 | | | 1 | | | | | | | |
| Coos Bay | OP. | 3 | 1 | | 1 | | | 1 | | | 1 | | | | | | |
| Springfield | OP. | 3 | 1 | | 1 | | | 1 | | | 1 | | | | | | |
| Roseburg | OP. | 3 | 1 | | 1 | | | 1 | | | 1 | | | | | | |
| Grants Pass | OP. | 3 | 1 | | 1 | | | 1 | | | 1 | | | | | | |
| Medford | OP & Acct. | 2 | 2 | 1 | 1 | | 1 | | 1 | | 1 | | | | | | |
| Medford | Acct. | 4 | 1 | | | | 1 | | | | 1 | | | | | | |
| Medford | Traffic | 1 | 1 | | 1 | | | | | | 1 | | | | | | |
| Lebanon | Minor | | | | | | | | | | | | | 1 | | | 1 |
| Hillsboro | Minor | | | | | | | | | | | | | 1 | | | 1 |
| Wheeler-Tillamoor | Minor | | | | | | | | | | | | | 1 | | | 1 |
| McMinnville | Minor | | | | | | | | | | | | | 1 | | | 1 |
| Toledo | Minor | | | | | | | | | | | | | 1 | | | 1 |
| Corvallis | Minor | | | | | | | | | | | | | 1 | | | 1 |
| Coquille | Minor | | | | | | | | | | | | | 1 | | | 1 |
| Crescent Lake | Minor | | | | | | | | | | | | | 1 | | | 1 |
| Oakridge | Minor | | | | | | | | | | | | | 1 | | | 1 |

Southern Pacific Company

SHASTA DIVISION

| Location | Type | Config. No. | Control Units | Control Units (Local Use Only) | Printer | Platen Printer With Emitter | | | | PTR | PTP | 1001 | 010 | 1912 |
|----------------------|------------|-------------|---------------|--------------------------------|---------|-----------------------------|----|----|----|-----|-----|------|-----|------|
| | | | | | | KB | CR | CP | CR | | | | | |
| Gerber | OP & Accl. | 2 | 2 | 1 | | 2 | 1 | 1 | 1 | 2 | | | | |
| Dunsmuir YO | OP. | 3 | 1 | | 1 | | 1 | 1 | | | | | | |
| Dunsmuir Dis-patcher | OP. | 1 | 2 | | 2 | | | 2 | | 2 | | | | |
| Ashland | OP. | 3 | 1 | | 1 | | 1 | 1 | 1 | | | | | |
| Klamath Falls | OP. | 3 | 2 | | 2 | | 1 | 2 | 2 | | | | | |
| Klamath Falls | Traffic | 1 | 1 | | 1 | | | | 1 | 1 | | | | |
| Klamath Falls | Acct. | 4 | 2 | 1 | 1 | 2 | | 2 | 2 | 2 | | | | |
| Chemault | Minor | | | | | | | | | | 1 | | | 1 |
| Redding | Minor | | | | | | | | | | 1 | | | 1 |
| Mt. Shasta | Minor | | | | | | | | | | 1 | | | 1 |
| Montague | Minor | | | | | | | | | | 1 | | | 1 |
| Aituras | OP. | 3 | 1 | | 1 | | 1 | 1 | 1 | | | | | |
| Wendel | Minor | | | | | | | | | | | | 1 | 1 |
| Weed | Minor | | | | | | | | | | | | 1 | 1 |

SALT LAKE DIVISION

| Location | Type | Config. No. | Control Units | Control Units (Local Use Only) | Printer | Platen Printer With Emitter | | | | PTR | PTP | 1001 | 010 | 1912 |
|-------------------|---------|-------------|---------------|--------------------------------|---------|-----------------------------|----|----|----|-----|-----|------|-----|------|
| | | | | | | KB | CR | CP | CR | | | | | |
| Ogden Yard Office | OP. | 3 | 2 | | 2 | | 2 | 2 | 2 | | | | | |
| Ogden Yard Office | Acct. | 4 | 3 | 1 | | 3 | | 3 | 3 | 3 | | | | |
| Ogden Dispatcher | OP. | 1 | 2 | | 2 | | 2 | 2 | 2 | 2 | | | | |
| Sparks | OP. | 3 | 1 | | 1 | | 1 | 1 | 1 | 1 | | | | |
| Fernley | OP. | 3 | 1 | | 1 | | 1 | 1 | 1 | 1 | | | | |
| Carlin | OP. | 3 | 1 | | 1 | | 1 | 1 | 1 | 1 | | | | |
| Mina | Minor | | | | | | | | | | 1 | 1 | | |
| Imlay | Minor | | | | | | | | | | 1 | 1 | | |
| Wells | Minor | | | | | | | | | | 1 | 1 | | |
| Reno | Acct. | 4 | 1 | | 1 | 1 | 1 | 1 | 1 | 1 | | | | |
| Reno | Traffic | 1 | 1 | | 1 | | | | | | | | | |

SACRAMENTO DIVISION

| Location | Type | Config. No. | Control Units | Control Units (Local Use Only) | Printer | Platen Printer With Emitter | KB | CR | CP | PTR | PTP | 1001 | 010 | 1912 |
|-------------|----------------|-------------|---------------|--------------------------------|---------|-----------------------------|----|----|----|-----|-----|------|-----|------|
| Sacramento | YO OP. | 3 | 1 | | 1 | | 1 | 1 | 1 | | | | | |
| Sacramento | YO Acct. | 4 | 2 | 1 | 1 | 2 | 2 | | | 2 | 2 | | | |
| Sacramento | TO Traffic | 1 | 1 | | 1 | | 1 | | | 1 | 1 | | | |
| Sacramento | Dis-patcher | 1 | 2 | | 2 | | 2 | | | 2 | 2 | | | |
| Roseville | Hump OP. | 3 | 2 | | 2 | | 2 | 2 | 2 | | | | | 2 |
| Roseville | YO OP. | 3 | 1 | | 1 | | 1 | 1 | 1 | | | | | |
| Roseville | YO Acct. | 4 | 3 | 1 | | 3 | 3 | | | 3 | 3 | | | |
| Roseville | PFE OP. | 3 | 1 | | 1 | | 1 | 1 | 1 | | | | | |
| Roseville | East OP. | 3 | 1 | | 1 | | 1 | 1 | 1 | | | | | |
| End | Remote Listing | | | | | | | | | | | | | |
| Roseville | Towers | | | | | | | | | | | 1 | 1 | |
| Marysville | Minor | | | | | | | | | | | 1 | 1 | |
| Placerville | Minor | | | | | | | | | | | 1 | 1 | |
| Woodland | Minor | | | | | | | | | | | 1 | 1 | |

Southern Pacific Company

WESTERN DIVISION

| Location | Type | Config. No. | Control Units | Control Units (Local Use Only) | Printer | Platen Printer With | | | PTR | PTP | 1001 | 010 | 1912 |
|------------------------|------------|-------------|---------------|--------------------------------|---------|---------------------|----|----|-----|-----|------|-----|------|
| | | | | | | Emitter | KB | CR | | | | | |
| Hayward | Minor | | | | | | | | | 1 | | 1 | |
| Mulford | Minor | | | | | | | | | 1 | | 1 | |
| Newark | Minor | | | | | | | | | 1 | | 1 | |
| Niles | OP & Acct. | 2 | 1 | 2 | | 2 | 1 | 1 | 1 | | | | 2 |
| Martinez | OP. | 3 | 1 | | 1 | | 1 | 1 | | | | | |
| Port Chicago | OP. | 3 | 1 | | 1 | | 1 | 1 | | | | | |
| Tracy | OP & Acct. | 2 | 4 | 2 | 2 | 2 | 3 | 2 | 2 | 2 | | | 2 |
| Tracy | Acct. | 4 | 1 | | 1 | | 1 | 1 | | | | | |
| Lodi | OP. | 3 | 1 | | 1 | | 1 | 1 | | | | | |
| Stockton | OP. | 3 | 1 | | 1 | | 1 | 1 | | | | | |
| Stockton | Acct. | 4 | 1 | | 1 | | 1 | | 1 | | | | 1 |
| Stockton | Traffic | 1 | 1 | | 1 | | 1 | | | 1 | | | 1 |
| Modesto | OP. | 3 | 1 | | 1 | | 1 | 1 | | | | | |
| West Oakland Tower | OP. | 3 | 1 | | 1 | | 1 | 1 | | | | | |
| Oakland Home- stead | OP. | 3 | 1 | | 1 | | 1 | 1 | | | | | |
| Oakland-East Oak. | OP. | 3 | 1 | | 1 | | 1 | 1 | | | | | |

| Location | Type | Config. No. | Control Units (Local Use Only) | Printer | Platen Printer With Emitter | | | | | PTR | PTP | 1001 | 010 | 1912 |
|---------------------------|---------|-------------|--------------------------------|---------|-----------------------------|----|----|----|----|-----|-----|------|-----|------|
| | | | | | KB | CR | CP | CR | CP | | | | | |
| Oakland - Elm-hurst | OP. | 3 | 1 | 1 | 1 | 1 | 1 | 1 | 1 | | | | | |
| Oakland-Chevrolet | OP. | 3 | 1 | 1 | 1 | 1 | 1 | 1 | 1 | | | | | |
| Oakland-Desert | OP. | 3 | 1 | 1 | 1 | 1 | 1 | 1 | 1 | | | | | |
| Oakland-Emeryville | OP. | 3 | 1 | 1 | 1 | 1 | 1 | 1 | 1 | | | | | |
| Oakland-Richmond Transfer | OP. | 3 | 1 | 1 | 1 | 1 | 1 | 1 | 1 | | | | | |
| Oakland-Yard Office | OP. | 3 | 1 | 1 | 1 | 1 | 1 | 1 | 1 | | | | | |
| Oakland-Yard Office | Acct. | 4 | 4 | 2 | 4 | 4 | 4 | 4 | 4 | 4 | 4 | | | |
| Oakland Traffic Office | Traffic | 1 | 1 | 1 | 1 | 1 | 1 | 1 | 1 | 1 | 1 | | | |
| Oakland Dispatcher | OP. | 1 | 2 | 2 | 2 | 2 | 2 | 2 | 2 | 2 | 2 | | | |
| Milpitas Rodeo | Minor | | | | | | | | | | | 1 | 1 | 1 |
| Pittsburg | Minor | | | | | | | | | | | 1 | 1 | 1 |
| East Pleasanton | Minor | | | | | | | | | | | 1 | 1 | 1 |
| Lombard-Napa Jct. | OP. | 3 | 1 | 1 | 1 | 1 | 1 | 1 | 1 | 1 | 1 | 1 | 1 | 1 |

| Location | Type | Config. No. | Control Units | Control Units (Local Use Only) | Printer | Platen Printer With Emitter | KB | CR | CP | PTR | PTP | 1001 | 010 | 1912 |
|-----------|-------|-------------|---------------|--------------------------------|---------|-----------------------------|----|----|----|-----|-----|------|-----|------|
| Suisun | Minor | | | | | | | | | | | 1 | 1 | 1 |
| Los Banos | Minor | | | | | | | | | | | 1 | 1 | 1 |
| Mendota | Minor | | | | | | | | | | | 1 | 1 | 1 |
| Merced | Minor | | | | | | | | | | | 1 | 1 | 1 |

COAST DIVISION

| Location | Type | Config. Control No. | Control Units (Local Use Only) | Printer | Platen Printer With Emitter | | | CP | PTR | PTP | 1001 | 010 | 1912 |
|---------------------------|----------------|---------------------|--------------------------------|---------|-----------------------------|----|----|----|-----|-----|------|-----|------|
| | | | | | KB | CR | CR | | | | | | |
| San Luis Obispo | OP. | 3 | 1 | 1 | 1 | 1 | 1 | | | | | | |
| Salinas | OP. | 3 | 2 | 2 | 1 | 2 | 2 | | | | | | |
| Watsonville Jct. | OP. | 3 | 2 | 2 | 1 | 2 | 2 | | | | | | |
| Watsonville Jct. | Acct. | 4 | 5 | 1 | 5 | 5 | 5 | | | 5 | | | |
| San Jose | OP & Acct. | 2 | 4 | 2 | 2 | 2 | 2 | | | 2 | | | 1 |
| San Jose | Traffic | 1 | 1 | 1 | 1 | | | | | 1 | | | |
| San Jose - West | Remote Listing | | | | | | | | | | | | |
| End | | | | | | | | | | | | | |
| Bayshore | OP. | 3 | 2 | 2 | 2 | 2 | 2 | | | | | | |
| Bayshore | Acct. | 4 | 2 | 1 | 2 | 2 | 2 | | | 2 | | | |
| Mission Bay | OP. | 3 | 1 | 1 | 1 | 1 | 1 | | | | | | |
| South City | OP. | 3 | 1 | 1 | 1 | 1 | 1 | | | | | | |
| San Francisco Dispatch | OP. | 1 | 2 | 2 | 2 | | | | | 2 | | | 2 |
| San Francisco Traffic | Traffic | 1 | 1 | 1 | 1 | | | | | 1 | | | 1 |
| San Francisco T.S.B | Traffic | 1-A | 6 | 6 | 6 | | | | | 6 | | | 6 |
| San Francisco Minor Input | OP. | 3 | 2 | 2 | 2 | | | | | | | | 2 |

| Location | Type | Config. No. | Control Units | Control Units (Local Use Only) | | Platen Printer | | | | | | | | | | | |
|--|------------|-------------|---------------|--------------------------------|--------------|----------------|----|----|-----|-----|------|-----|------|---|---|--|---|
| | | | | Printer | With Emitter | KB | CR | CP | PTR | PTP | 1001 | 010 | 1912 | | | | |
| San Francisco Region Car Distributor | OP. | 1-A | 4 | 2 | 4 | 4 | | | | 4 | | | | | | | |
| San Francisco System Car Distributor | OP. | 1-A | 4 | 2 | 4 | 4 | | | | 4 | | | | | | | |
| San Francisco Rating & Revising Bureau | Acct. | 1 | 2 | | | 2 | | | | 2 | | | | 2 | | | |
| San Francisco Data Center | Acct. | 1 | 2 | 1 | 2 | | | | | 2 | 1 | 1 | 1 | 1 | | | |
| Lompoc | Minor | | | | | | | | | | | | | | 1 | | 1 |
| Guadalupe | OP & Acct. | 2 | 2 | 1 | | 2 | | | | 2 | 1 | 1 | 1 | 2 | | | |
| Santa Cruz | Minor | | | | | | | | | | | | | | 1 | | 1 |
| Gilroy | Minor | | | | | | | | | | | | | | 1 | | 1 |
| Sunnyvale | Minor | | | | | | | | | | | | | | 1 | | 1 |
| Redwood City | Minor | | | | | | | | | | | | | | 1 | | 1 |

SAN JOAQUIN DIVISION

| Location | Type | Config. No. | Control Units | Control Units (Local Use Only) | Printer | Platen Printer | | KB | CR | CP | PTR | PTP | 1001 | 010 | 1912 |
|----------------|------------|----------------|------------------|--------------------------------------|---------|-----------------|---|----|----|----|-----|-----|------|-----|------|
| | | | | | | With Emitter | 2 | | | | | | | | |
| Mojave | OP & Acct. | 2 | 2 | 1 | | 2 | 2 | 1 | 1 | 1 | 1 | 2 | | | |
| Bakersfield YO | OP & Acct. | 2 | 4 | 2 | 2 | 2 | 3 | 2 | 2 | 2 | 2 | 2 | | | 1 |

LOS ANGELES DIVISION

| Location | Type | Config. No. | Control Units | Control Units (Local Use Only) | Printer | Platen Printer With | | | | PTR | PTP | 1001 | 010 | 1912 |
|---------------------|----------------|-------------|---------------|--------------------------------|---------|---------------------|----|----|---------|-----|-----|------|-----|------|
| | | | | | | KB | CR | CP | Emitter | | | | | |
| El Centro | OP. | 3 | 2 | | 2 | 1 | 2 | 2 | | | | | | |
| El Centro | Acct. | 4 | 3 | 1 | | 3 | | | 3 | 3 | | | | |
| Indio | OP & Acct. | 2 | 2 | 1 | 1 | 2 | 1 | 1 | 1 | 1 | | | | |
| Colton | OP & Acct. | 2 | 4 | 2 | 2 | 3 | 2 | 2 | 2 | 2 | | | | |
| Kaiser | OP. | 3 | 1 | | 1 | 1 | 1 | 1 | | | | | | |
| City of Industry | OP. | 3 | 2 | | 2 | 1 | 2 | 2 | | | | | | |
| Tweedy | OP. | 3 | 1 | | 1 | 1 | 1 | 1 | | | | | | |
| Gemco | OP. | 3 | 2 | | 2 | 1 | 2 | 2 | | | | | | |
| Oxnard | OP | 3 | 1 | | | 1 | 1 | 1 | 1 | | | | | |
| Oxnard | Acct. | 4 | 1 | | | 1 | 1 | | 1 | 1 | | | | |
| Santa Barbara | OP. | 3 | 1 | | 1 | 1 | 1 | 1 | | | | | | |
| Yuma Yard | OP. | 3 | 2 | | 1 | 1 | 2 | 2 | | 1 | | | | 1 |
| Yuma Yard | Acct. | 4 | 2 | 1 | | 2 | | | 2 | 2 | | | | |
| Yuma Subway | Remote Listing | | | | | | | | | | | | | |
| Yuma Point | Remote Listing | | | | | | | | | | | | | |
| LA-Taylor Bull Ring | OP. | 3 | 1 | | 1 | 1 | 1 | 1 | | | | | | 1 |

| Location | Type | Config. No. | Control Units | Control Units (Local Use Only) | | Printer | | Platen Printer With Emitter | | PTR | PTP | 1001 | 010 | 1912 |
|----------------------|----------------|-------------|---------------|--------------------------------|---------|---------|---------|-----------------------------|----|-----|-----|------|-----|------|
| | | | | Control Units | Printer | Printer | Printer | KB | CR | | | | | |
| LA UP | OP. | 3 | 1 | 1 | 1 | 1 | 1 | 1 | 1 | | | | | |
| LA Dispatcher | OP. | 1 | 2 | 2 | | | | | | 2 | 2 | | | |
| Thermal | Minor | | | | | | | | | | | 1 | 1 | |
| Pomona | Minor | | | | | | | | | | | 1 | 1 | |
| Norwalk | Minor | | | | | | | | | | | 1 | 1 | |
| Anaheim | Minor | | | | | | | | | | | 1 | 1 | |
| Santa Ana | Minor | | | | | | | | | | | 1 | 1 | |
| Dolores | Minor | | | | | | | | | | | 1 | 1 | |
| Wilmington | Traffic | 1 | 1 | 1 | 1 | | | | | 1 | 1 | | | |
| Riverside | Traffic | 1 | 1 | 1 | 1 | | | | | 1 | 1 | | | |
| Bakersfield Dispatch | OP. | 1 | 2 | 2 | | | | | | 2 | 2 | | | |
| Bakersfield TO | Traffic | 1 | 1 | 1 | | | | | | 1 | 1 | | | |
| Bakersfield Edison | Remote Listing | | | | | | | | | | | | | |
| Fresno Traffic | Traffic | 1 | 1 | 1 | | | | | | 1 | 1 | | | |
| Fresno Yard | OP. | 3 | 2 | 2 | | | | | | 1 | 2 | 2 | | 1 |
| Fresno Yard | Acct. | 4 | 3 | 3 | 1 | | | | | 3 | 3 | | | |
| Fresno Merced St. | Remote Listing | | | | | | | | | | | | | |

| Location | Type | Config. No. | Control Units | Control Units (Local Use Only) | Printer | Platen Printer With Emitter | KB | CR | CP | PTR | PTP | 1001 | 010 | 1912 |
|-------------|-------|-------------|---------------|--------------------------------|---------|-----------------------------|----|----|----|-----|-----|------|-----|------|
| Famoso | Minor | | | | | | 1 | | | | | 1 | | 1 |
| Delano | Minor | | | | | | 1 | | | | | 1 | | 1 |
| Jovista | Minor | | | | | | 1 | | | | | 1 | | 1 |
| Porterville | Minor | | | | | | 1 | | | | | 1 | | 1 |
| Sanger | Minor | | | | | | 1 | | | | | 1 | | 1 |
| Coalinga | Minor | | | | | | 1 | | | | | 1 | | 1 |
| Huron | Minor | | | | | | 1 | | | | | 1 | | 1 |
| Hanford | Minor | | | | | | 1 | | | | | 1 | | 1 |
| Selma | Minor | | | | | | 1 | | | | | 1 | | 1 |

TUCSON DIVISION

| Location | Type | Config. No. | Control Units | Control Units (Local Use Only) | Printer | Platen Printer With Emitter | KB | CR | CP | PTR | PTP | 1001 | 010 | 1912 |
|----------------------|----------------|-------------|---------------|--------------------------------|---------|-----------------------------|----|----|----|-----|-----|------|-----|------|
| Tucson Traffic Off. | Traffic | 1 | 1 | | 1 | | 1 | | | 1 | | | | 1 |
| Tucson - 22nd St. | Acct. | 4 | 2 | 1 | | 2 | | | | 2 | | | | 2 |
| Tucson - 22nd St. | OP. | 3 | 2 | | 2 | | 1 | 2 | 2 | | | | | 1 |
| Tucson - 36th St. | Remote Listing | | | | | | | | | | | | | |
| Tucson - Yard-master | Remote Listing | | | | | | | | | | | | | |
| Tucson PFE | OP. | 3 | 1 | | 1 | | 1 | 1 | 1 | | | | | |
| Tucson Dispatcher | OP. | 1 | 2 | | 2 | | 2 | | | 2 | | | | 2 |
| Phoenix | OP. | 3 | 1 | | 1 | | 1 | 1 | 1 | | | | | |
| Phoenix | Acct. | 4 | 2 | 1 | | 2 | | | | 2 | | | | 2 |
| Phoenix | Traffic | 1 | 1 | | 1 | | 1 | | | 1 | | | | 1 |
| Globe | Minor | | | | | | | | | | | | | 1 |
| Bowie | Minor | | | | | | | | | | | | | 1 |
| Benson | Minor | | | | | | | | | | | | | 1 |
| Nogales | Minor | | | | | | | | | | | | | 1 |
| Willcox | Minor | | | | | | | | | | | | | 1 |
| Casagrande | Minor | | | | | | | | | | | | | 1 |

| Location | Type | Config. Control No. Units | Control Units (Local Use Only) | Printer | Platen Printer With Emitter | KB | CR | CP | PTR | PTP | 1001 | 010 | 1912 |
|----------|-------|------------------------------|--------------------------------------|---------|-----------------------------------|----|----|----|-----|-----|------|-----|------|
| Gila | Minor | | | | | | | | | | 1 | 1 | |
| Mesa | Minor | | | | | | | | | | 1 | 1 | |
| Hayden | Minor | | | | | | | | | | 1 | 1 | |

RIO GRANDE DIVISION

| Location | Type | Config. No. | Control Units | Control Units (Local Use) | | Platen Printer | | KB | CR | CP | PTR | PTP | 1001 | 010 | 1912 |
|--------------------------|------------|-------------|---------------|---------------------------|---------|----------------|----------------|----|----|----|-----|-----|------|-----|------|
| | | | | Control Units Only | Printer | With Emitter | Platen Printer | | | | | | | | |
| Tucumcari | OP. | 3 | 1 | | 1 | 1 | 1 | 1 | 1 | | | 1 | | | |
| Tucumcari | Acct. | 4 | 1 | | 1 | 1 | | | | 1 | 1 | | | | |
| El Paso-Dallas St. | OP & Acct. | 2 | 4 | 2 | 2 | 2 | 2 | 2 | 2 | 2 | 2 | 2 | | | |
| El Paso-Adair | OP. | 3 | 1 | | 1 | | 1 | 1 | | | | | | | |
| El Paso-Adair | Acct. | 4 | 1 | | 1 | 1 | | | 1 | 1 | | | | | |
| Transload Dock | | | | | | | | | | | | | | | |
| El Paso - Traffic Office | Traffic | 1 | 1 | | 1 | | 1 | | | 1 | 1 | | | | |
| Lordsburg | OP. | 3 | 1 | | | 1 | 1 | 1 | | | | | | | |
| Douglas | OP. | 3 | 1 | | | 1 | 1 | 1 | | | 1 | | | | |
| Douglas | Acct. | 4 | 1 | | | 1 | 1 | | | | 1 | 1 | | | |
| Deming | OP. | 3 | 1 | | 1 | | 1 | 1 | | 1 | | | | | |
| Carizzozo | Minor | | | | | | | | | | | | 1 | 1 | |
| Bisbee Junction | Minor | | | | | | | | | | | | 1 | 1 | |
| Vaughan | Minor | | | | | | | | | | | | 1 | 1 | |

Southern Pacific Company

SAN ANTONIO DIVISION

| Location | Type | Config. No. | Control Units | Control Units (Local Use Only) | Control Units (Local Use Only) Printer | Platen Printer With Emitter | KB | CR | CP | PTR | PTP | 1001 | 010 | 1912 |
|----------------|-------------|-------------|---------------|--------------------------------|--|-----------------------------|----|----|----|-----|-----|------|-----|------|
| San Antonio | OP & Acct. | 2 | 4 | 2 | 2 | 2 | 3 | 2 | 2 | 2 | 2 | | | |
| San Antonio | Traffic | 1 | 1 | | 1 | | 1 | | | 1 | 1 | | | |
| Alice | OP. | 3 | 1 | | 1 | | 1 | 1 | 1 | | | | | |
| Edinburg | OP & Acct. | 2 | 2 | 1 | | 2 | 2 | 1 | 1 | 1 | 2 | | | |
| Corpus Christi | OP. | 3 | 1 | | 1 | | 1 | 1 | 1 | | | | | |
| Corpus Christi | Acct. | 4 | 1 | | | 1 | 1 | | | 1 | 1 | | | |
| Corpus Christi | Traffic | 1 | 1 | | | | 1 | | | 1 | 1 | | | |
| Gregory | OP. | 3 | 1 | | 1 | | 1 | 1 | 1 | | | | | |
| Eagle Pass | OP. & Acct. | 2 | 2 | 1 | | 2 | 2 | 1 | 1 | 1 | 2 | | | |
| Del Rio | OP. | 3 | 1 | | 1 | | 1 | 1 | 1 | | | | | |
| Valentine | OP. | 3 | 1 | | 1 | | 1 | 1 | 1 | | | | | |
| Brownsville | OP. | 3 | 1 | | 1 | | 1 | 1 | 1 | | | | | |
| Gonzales | Minor | | | | | | | | | | | 1 | 1 | |
| Skidmore | Minor | | | | | | | | | | | 1 | 1 | |
| McAllen | Minor | | | | | | | | | | | 1 | 1 | |
| Harlingen | Minor | | | | | | | | | | | 1 | 1 | |
| Harlingen | Traffic | 1 | 1 | | 1 | | 1 | | | 1 | 1 | | | |

| Location | Type | Config. No. | Control Units | Control Units (Local Use Only) | Printer | Platen Printer With Emitter | KB | CR | CP | PTR | PTP | 1001 | 010 | 1912 |
|-----------|-------|-------------|---------------|--------------------------------|---------|-----------------------------|----|----|----|-----|-----|------|-----|------|
| Vvalde | Minor | | | | | | | | | | | 1 | 1 | |
| Spofford | Minor | | | | | | | | | | | 1 | 1 | |
| Sanderson | Minor | | | | | | | | | | | 1 | 1 | |

DALLAS - AUSTIN DIVISION

| Location | Type | Config. No. | Control Units | Control Units (Local Use) | | Platen Printer | | KB | CR | CP | PTR | PTP | 1001 | 010 | 1912 |
|--------------------|------------|-------------|---------------|---------------------------|--------------|----------------|--------------|----|----|----|-----|-----|------|-----|------|
| | | | | Printer | With Emitter | Printer | With Emitter | | | | | | | | |
| Hearne | OP. | 3 | 1 | | 1 | | | 1 | 1 | | | | | | |
| Hearne | Op & Acct. | 2 | 2 | 1 | 1 | 1 | 2 | 1 | 1 | 1 | 1 | | | | |
| Ennis | OP. | 3 | 1 | | 1 | | | 1 | 1 | | | | | | |
| Ennis | OP & Acct. | 2 | 2 | 1 | 2 | 2 | 2 | 1 | 1 | 1 | 2 | | | | |
| Fort Worth | OP & Acct. | 2 | 2 | 1 | 2 | 2 | 2 | 1 | 1 | 1 | 2 | | | | |
| Dallas-Miller Yard | OP & Acct. | 2 | 2 | 1 | 2 | 2 | 2 | 1 | 1 | 1 | 2 | | | | |
| Dallas-Miller Yard | OP. | 3 | 1 | | 1 | | | 1 | 1 | | | | | | |
| Dallas Yard Off | OP. | 3 | 1 | | 1 | | 1 | 1 | 1 | | | | | | |
| Dallas Traffic | Traffic | 1 | 1 | | 1 | | 1 | | | 1 | 1 | | | | |
| Austin | OP. | 3 | 1 | | 1 | | 1 | 1 | 1 | | | | | | |
| Austin | Acct. | 4 | 1 | | 1 | 1 | 1 | | | 1 | 1 | | | | |
| Waco | OP. | 3 | 1 | | 1 | | 1 | 1 | 1 | | | | | | |
| Sherman | OP. | 3 | 1 | | 1 | | 1 | 1 | 1 | | | | | | |
| Dennison | OP. | 3 | 1 | | 1 | | 1 | 1 | 1 | | | | | | |
| Brenham | Minor | | | | | | | | | | | | | 1 | 1 |
| Corsicana | OP & Acct. | 2 | 2 | | 2 | 2 | 2 | 1 | 1 | 1 | 2 | | | | |
| Jacksonville | Minor | | | | | | | | | | | | | 1 | 1 |
| Giddings | Minor | | | | | | | | | | | | | 1 | 1 |

Southern Pacific Company

HOUSTON DIVISION

| Location | Type | Config. No. | Control Units | Control Units (Local Use Only) | Printer | Platen Printer | | | | PTR | PTP | 1001 | 010 | 1912 |
|--------------------------------|----------------|-------------|---------------|--------------------------------|---------|----------------|----|----|----|-----|-----|------|-----|------|
| | | | | | | With Emitter | KB | CR | CP | | | | | |
| Houston-Agency | Acct. | 4 | 2 | 1 | 1 | 2 | 2 | 2 | 2 | 2 | | | | |
| Houston-Englewood | OP. | 3 | 2 | 1 | 2 | 2 | 2 | 2 | 2 | | | | | |
| Houston-Englewood | Acct. | 4 | 2 | | | 2 | | 2 | 2 | | | | | |
| Houston-Englewood | OP. | 3 | 1 | | 1 | 1 | 1 | 1 | 1 | | | | | |
| West End | | | | | | | | | | | | | | |
| Houston-Englewood | Remote Listing | | | | | | | | | | | | | |
| Houston Car District | OP. | 1-A | 4 | 2 | 4 | 4 | 4 | 4 | 4 | 4 | | | | |
| Houston Dispatcher | OP. | 1 | 3 | | 3 | 3 | 3 | 3 | 3 | 3 | | | | |
| Houston Traffic Office | Traffic | 1 | 1 | | 1 | 1 | 1 | 1 | 1 | 1 | | | | |
| Houston Central Service Bureau | OP. | 1 | 1 | | 1 | 1 | 1 | 1 | 1 | 1 | | | | |
| Houston-Minor Input | OP. | 3 | 1 | | 1 | 1 | 1 | 1 | 1 | 1 | | | | |
| Navigation | OP. | 3 | 1 | | 1 | 1 | 1 | 1 | 1 | 1 | | | | |
| Chaney | OP. | 3 | 1 | | 1 | 1 | 1 | 1 | 1 | 1 | | | | |
| Shreveport | OP & Acct. | 2 | 4 | 2 | 2 | 2 | 2 | 2 | 2 | 2 | 2 | 2 | 2 | 2 |
| Lufkin | OP & Acct. | 2 | 2 | 1 | 1 | 2 | 2 | 1 | 1 | 1 | 1 | 1 | 1 | 2 |

| Location | Type | Config. No. | Control Units | Platen Printer | | | | | | | | | | | | | |
|-------------|------------|-------------|---------------|------------------|---------|--------------|----|----|----|-----|-----|------|-----|------|--|--|---|
| | | | | (Local Use Only) | Printer | With Emitter | KB | CR | CP | PTR | PTP | 1001 | 010 | 1912 | | | |
| Glidden | OP & Acct. | 2 | 2 | 1 | | 2 | 2 | 1 | 1 | 1 | 2 | | | | | | |
| Victoria | OP & Acct. | 2 | 2 | 1 | | 2 | 2 | 1 | 1 | 1 | 2 | | | | | | |
| Galveston | OP | 3 | 1 | | 1 | | 1 | 1 | 1 | | | | | | | | |
| Eagle Lake | OP & Acct. | 2 | 2 | 1 | | 2 | 2 | 2 | 1 | 1 | 2 | | | | | | |
| Pasadena | Minor | | | | | | | | | | | 1 | | | | | 1 |
| Nocogdoches | Minor | | | | | | | | | | | 1 | | | | | 1 |
| Corrigan | Minor | | | | | | | | | | | 1 | | | | | 1 |
| Wharton | Minor | | | | | | | | | | | 1 | | | | | 1 |
| Yoakum | Minor | | | | | | | | | | | 1 | | | | | 1 |
| New Gulf | Minor | | | | | | | | | | | 1 | | | | | 1 |
| Dayton | Minor | | | | | | | | | | | 1 | | | | | 1 |

LAFAYETTE DIVISION

| Location | Type | Config. No. | Control Units | Control Units (Local Use) | | Platen Printer With Emitter | KB | CR | CP | PTR | PTP | 1001 | 010 | 1912 |
|----------------|------------|-------------|---------------|---------------------------|---------|-----------------------------|----|----|----|-----|-----|------|-----|------|
| | | | | Only | Printer | | | | | | | | | |
| Avondale | OP. | 3 | 2 | | 2 | | 1 | 2 | 2 | | | | | |
| Avondale | Acct. | 4 | 2 | 1 | | 2 | 2 | | 2 | 2 | | | | |
| New Orleans | Traffic | 5 | 1 | | 1 | | 1 | | 1 | 1 | | | | |
| New Iberia | OP & Acct. | 2 | 2 | 1 | 1 | 1 | 2 | 1 | 1 | 2 | 1 | | | |
| Lafayette | OP. | 3 | 1 | | 1 | | 1 | 1 | | | | | | |
| Lafayette | OP & Acct. | 2 | 2 | 1 | 2 | 2 | 1 | 1 | 1 | 2 | | | | |
| Alexandria | OP. | 3 | 1 | | 1 | | 1 | 1 | 1 | | | | | |
| Lake Charles | OP. | 3 | 1 | | 1 | | | 1 | 1 | | | | | |
| Lake Charles | OP & Acct. | 2 | 2 | 1 | 1 | 2 | 2 | 1 | 1 | 1 | 2 | | | |
| Lake Charles | Traffic | 1 | 1 | | 1 | | 1 | | 1 | 1 | | | | |
| Beaumont | OP. | 3 | 2 | | 2 | | 1 | 2 | 2 | | | | | |
| Beaumont | Acct. | 4 | 2 | 1 | | 2 | 2 | | 2 | 2 | | | | |
| Beaumont | Traffic | 1 | 1 | | 1 | | 1 | | 1 | 1 | | | | |
| Baytown | Minor | | | | | | | | | | | | 1 | 1 |
| Race Land Jct. | Minor | | | | | | | | | | | | 1 | 1 |
| Morgan City | Minor | | | | | | | | | | | | 1 | 1 |
| Baldwin | Minor | | | | | | | | | | | | 1 | 1 |

| Location | Type | Config. No. | Control Units | Platen Printer | | | | | | | | | |
|-----------|------------|-------------|---------------|------------------|---------|--------------|----|----|----|-----|-----|------|-----|
| | | | | (Local Use Only) | Printer | With Emitter | KB | CR | CP | PTR | PTP | 1001 | 010 |
| Eunice | Minor | | | | | | | | | | 1 | 1 | |
| Echo | Minor | | | | | | | | | | 1 | 1 | |
| Schriever | OP & Acct. | 2 | 2 | 1 | 1 | 1 | 2 | 1 | 1 | 1 | 1 | 1 | |

NORTHWEST PACIFIC DIVISION

| Location | Type | Config. No. | Control Units | Control Units (Local Use Only) | Printer | Platen Printer With Emitter | | | | | | | |
|---------------------|-------------|-------------|---------------|--------------------------------|---------|-----------------------------|----|----|-----|-----|------|-----|------|
| | | | | | | KB | CR | CP | PTR | PTP | 1001 | 010 | 1912 |
| Eureka | OP & Acct. | 2 | 4 | 2 | 2 | 2 | 2 | 2 | 2 | 2 | | | |
| Eureka | Traffic | 1 | 1 | | 1 | | | 1 | 1 | | | | |
| Willits | OP. | 3 | 2 | | 2 | | 1 | 2 | 2 | | | | |
| Schellville | OP. & Acct. | 2 | 2 | 1 | | 2 | 2 | 1 | 1 | 1 | 2 | | |
| San Rafael Dispatch | OP. | 1 | 1 | | 1 | | 1 | | 1 | 1 | | | |
| San Rafael | Minor | | | | | | | | | | 1 | 1 | |
| Arcata | Minor | | | | | | | | | | 1 | 1 | |
| Ft. Seward | Minor | | | | | | | | | | 1 | 1 | |
| Uriah | Minor | | | | | | | | | | 1 | 1 | |
| Healdsburg | Minor | | | | | | | | | | 1 | 1 | |
| Petaluma | Minor | | | | | | | | | | 1 | 1 | |
| Santa Rosa | Minor | | | | | | | | | | 1 | 1 | |
| Santa Rosa | Acct. | 4 | 1 | | 1 | | 1 | | 1 | 1 | | | |

S D & A E DIVISION

| Location | Type | Config. No. | Control Units | Control Units (Local Use Only) | Printer | Platen Printer With Emitter | | | | | | | |
|-----------|------|-------------|---------------|--------------------------------|---------|-----------------------------|----|----|-----|-----|------|-----|------|
| | | | | | | KB | CR | CP | PTR | PTP | 1001 | 010 | 1912 |
| San Diego | OP. | 3 | 1 | | 1 | | | | | | 1 | 1 | 1 |

PACIFIC ELECTRIC DIVISION

| Location | Type | Config. No. | Control Units | Control Units (Local Use Only) | Printer | Platen Printer With Emitter | KB | CR | CP | PTR | PTP | 1001 | 010 | 1912 |
|----------------|------------|-------------|---------------|--------------------------------|---------|-----------------------------|----|----|----|-----|-----|------|-----|------|
| Los Angeles PE | Acct. | 4 | 2 | 1 | 1 | 2 | 2 | | | 2 | 2 | | | |
| Buhe | OP. | 3 | 1 | | 1 | | 1 | 1 | 1 | | | | | |
| Los Nietos | OP. | 3 | 1 | | | 1 | 1 | 1 | 1 | | 1 | | | |
| Los Nietos | Acct. | 4 | 1 | | | 1 | 1 | | | 1 | 1 | | | |
| Long Beach | OP & Acct. | 2 | 2 | 1 | | 2 | 2 | 1 | 1 | 1 | 2 | | | |
| Baldwin Park | OP. | 3 | 1 | | 1 | | 1 | 1 | 1 | | | | | |
| Eighth St. | OP. | 3 | 1 | | 1 | | 1 | 1 | 1 | | | | | |
| El Segundo | OP. | 3 | 1 | | 1 | | 1 | 1 | 1 | | | | | |
| Watson | OP. | 3 | 1 | | 1 | | 1 | 1 | 1 | | | | | |
| Graham | OP. | 3 | 1 | | 1 | | 1 | 1 | 1 | | | | | |
| PE-Dispatcher | OP. | 1 | 1 | | 1 | | 1 | | | 1 | 1 | | | |
| Torrance | Minor | | | | | | | | | | | 1 | | 1 |
| Wingfoot | Minor | | | | | | | | | | | 1 | | 1 |
| San Bernardino | Minor | | | | | | | | | | | 1 | | 1 |
| Hollywood | Minor | | | | | | | | | | | 1 | | 1 |
| Culver City | Minor | | | | | | | | | | | 1 | | 1 |

OFF LINE TRAFFIC OFFICES

| Location | Type | Config. No. | Control Units | Control Units (Local Use Only) | Printer | Platen Printer With Emitter | KB | CR | CP | PTR | PTP | 1001 | 010 | 1912 |
|----------------|---------|-------------|---------------|--------------------------------|---------|-----------------------------|----|----|----|-----|-----|------|-----|------|
| | | | | | | | | | | | | | | |
| Atlanta | Traffic | 5* | 1 | 1 | 1 | 1 | 1 | 1 | 1 | 1 | 1 | 1 | 1 | 1 |
| Birmingham | Traffic | 5 | 1 | 1 | 1 | 1 | 1 | 1 | 1 | 1 | 1 | 1 | 1 | 1 |
| Boston | Traffic | 5 | 1 | 1 | 1 | 1 | 1 | 1 | 1 | 1 | 1 | 1 | 1 | 1 |
| Buffalo | Traffic | 5 | 1 | 1 | 1 | 1 | 1 | 1 | 1 | 1 | 1 | 1 | 1 | 1 |
| Chicago | Traffic | 5 | 2 | 2 | 2 | 2 | 2 | 2 | 2 | 2 | 2 | 2 | 2 | 2 |
| Cincinnati | Traffic | 5 | 1 | 1 | 1 | 1 | 1 | 1 | 1 | 1 | 1 | 1 | 1 | 1 |
| Cleveland | Traffic | 5 | 1 | 1 | 1 | 1 | 1 | 1 | 1 | 1 | 1 | 1 | 1 | 1 |
| Denver | Traffic | 5 | 1 | 1 | 1 | 1 | 1 | 1 | 1 | 1 | 1 | 1 | 1 | 1 |
| Detroit | Traffic | 5 | 1 | 1 | 1 | 1 | 1 | 1 | 1 | 1 | 1 | 1 | 1 | 1 |
| Indianapolis | Traffic | 5 | 1 | 1 | 1 | 1 | 1 | 1 | 1 | 1 | 1 | 1 | 1 | 1 |
| Kansas City | Traffic | 5 | 1 | 1 | 1 | 1 | 1 | 1 | 1 | 1 | 1 | 1 | 1 | 1 |
| Memphis | Traffic | 5 | 1 | 1 | 1 | 1 | 1 | 1 | 1 | 1 | 1 | 1 | 1 | 1 |
| Milwaukee | Traffic | 5 | 1 | 1 | 1 | 1 | 1 | 1 | 1 | 1 | 1 | 1 | 1 | 1 |
| Minneapolis | Traffic | 5 | 1 | 1 | 1 | 1 | 1 | 1 | 1 | 1 | 1 | 1 | 1 | 1 |
| New York | Traffic | 5 | 1 | 1 | 1 | 1 | 1 | 1 | 1 | 1 | 1 | 1 | 1 | 1 |
| Philadelphia | Traffic | 5 | 1 | 1 | 1 | 1 | 1 | 1 | 1 | 1 | 1 | 1 | 1 | 1 |
| Pittsburgh | Traffic | 5 | 1 | 1 | 1 | 1 | 1 | 1 | 1 | 1 | 1 | 1 | 1 | 1 |
| Salt Lake City | Traffic | 1 | 1 | 1 | 1 | 1 | 1 | 1 | 1 | 1 | 1 | 1 | 1 | 1 |

| Location | Type | Config. No. | Control Units | Control Units (Local Use) | | Platen Printer | | | | | | | | | | | |
|-----------------|---------|-------------|---------------|---------------------------|---------|----------------|----|----|----|-----|-----|------|-----|------|--|--|--|
| | | | | Only | Printer | With Emitter | KB | CR | CP | PTR | PTP | 1001 | 010 | 1912 | | | |
| Seattle | Traffic | 1 | 1 | | 1 | | | 1 | | | | 1 | | | | | |
| St. Louis | Traffic | 5 | 1 | | 1 | | | 1 | | | | 1 | | | | | |
| Tulsa | Traffic | 5 | 1 | | 1 | | | 1 | | | | 1 | | | | | |
| Washington | Traffic | 5 | 1 | | 1 | | | 1 | | | | 1 | | | | | |
| Winston - Salem | Traffic | 5 | 1 | | 1 | | | 1 | | | | 1 | | | | | |

TABLE OF CONTENTS
IMPLEMENTATION AND INSTALLATION

| | Page |
|--|------|
| INTRODUCTION | 8-1 |
| PROGRAMMING | 8-1 |
| FIELD IMPLEMENTATION | 8-2 |
| IMPLEMENTATION OF CENTRAL AND REGIONAL FUNCTIONS | 8-3 |
| EQUIPMENT | 8-4 |
| APPLICATION CUTOVER | 8-5 |

LIST OF ILLUSTRATIONS

| Figure | | Page |
|--------|-------------------------|------|
| 8-1 | Implementation Schedule | 8-7 |

IMPLEMENTATION AND INSTALLATION

INTRODUCTION

The implementation and installation of the TOPS System will span approximately four years, starting in 1962. The central system is scheduled to be operative in July, 1964. Extensive preparation will be required in the areas of procedural refinement, programming, selection and training of personnel, and development of central records. Many of these activities will be undertaken at the same time.

Once the TOPS System is installed, it is anticipated that there will be a period requiring operation under special supervision, followed by periodic inspection and subsequent refinement of procedures, and then expansion.

The TOPS System will have far reaching effects on many areas of the Southern Pacific Company's operations. To achieve maximum success it is most important that highly qualified people be assigned to programming and implementation. Final results will be largely dependent upon the abilities and efforts of these people.

PROGRAMMING

Programming a TELE-PROCESSING System such as TOPS falls into two major categories: Supervisory Programming and Application Programming. The supervisory programs direct the operation of the central processor. They allow the programmers responsible for creating the application programs to ignore input-output timing and other equipment considerations. The application programs execute the particular functions required by the procedures.

The initial supervisory programs, diagnostic programs and some of the stand-by programs will be written by IBM personnel. Modifications and maintenance to these programs will be the responsibility of the Southern Pacific Company. The application programs will be written by Southern Pacific Company programmers, with technical assistance provided by IBM. IBM will also provide necessary training for Southern Pacific Company personnel who will participate in the programming of the TOPS System.

Based on the assumption that an average of ten program steps will be written each working day, the application programming is estimated to require approximately forty man years of effort by experienced programmers. To commence operations in July, 1964, it is necessary to establish a definite schedule for the programming effort.

Assuming a contractual date of July 15, 1962 or earlier, will be ready for system test in October, 1963. At this time, certain application programs must be ready to be tested. These are: Waybilling, Central Rating and Revising, Freight Billing, Cash Applications, Car Tracing, Manifesting, Special Accounts Reporting, and Train Movement. The supervisory programs, written by IBM programmers, will be ready for use in conjunction with the application programs at this same time.

After this date, the remaining program development will be scheduled to coincide with the implementation of the other applications in the TOPS System.

Southern Pacific Company

Southern Pacific Company manpower requirements to meet the preceding objectives will be:

1. A staff of programmers that will be available and trained on the IBM 7074 and IBM 1301 to be set-up in August, 1962; this staff will be increased to 10 by October, 1962 and 18 by April, 1963.
2. Two trained 1401 programmers that will be available by December, 1962.

The programmers must be trained to program the IBM 7750 and have an understanding of the supervisory programs so they can maintain the System after it is fully operational.

The schedule for completion of programming in the major applications is as follows:

| | |
|----------------|--|
| October, 1963 | Waybill Processing Central Rating and Revising Freight Billing Special Accounts Reporting Cash Application (San Francisco) |
| January, 1964 | Car Tracing Manifest Reporting Train Movement from I/O Locations |
| April, 1964 | Cash Application (Regional Centers) |
| December, 1964 | Industrial Service Center Functions |
| March, 1965 | Car Distribution Output to 7074 Processing |
| April, 1965 | Demmorage |
| July, 1965 | Diversions |
| October, 1965 | Performance Reporting |

FIELD IMPLEMENTATION

The scheduled cutover of applications on the TOPS System will require a thorough field implementation program. Specialists will be needed in yard office, traffic office and agency procedures. IBM personnel will be available to furnish technical assistance to Southern Pacific Company groups working in these areas. In addition to IBM personnel assigned in San Francisco, support will be available from other IBM branch offices serving Southern Pacific Company.

It is estimated that eighteen Southern Pacific Company personnel will be required to staff the field implementation program. Sixteen of these men will work as eight two-man teams. Each team will specialize in one application area, but will have a knowledge of all field procedures. The installation program will start with major emphasis on the accounting activity. The initial assignment of these teams

Southern Pacific Company

will be five to accounting implementation, two to operating implementation, and one to traffic office implementation. As accounting implementation proceeds, the assignment of the staff will gradually shift to five operating teams, two accounting teams and one traffic team. One man will be needed to supervise the accounting and traffic implementation.

The first phase of the field implementation activity will be detailed refinement of the implementation schedule by the original members of the TOPS study group. The next phase will be training the new teams in TOPS concepts and equipment. This should commence no later than September, 1962. Once this training is complete, the team members will apply the procedures to the situations in each yard office and agency, and make any modifications that may be required. As cutover approaches, local personnel will be trained in TOPS functions by these field teams. The installation of equipment will be under the supervision of these field teams, and they will supervise the cutover operation. After cutover, these men will be responsible for periodic inspection of each office and subsequent refinement of procedures.

It is most important that the team members be thoroughly familiar with all aspects of the TOPS System. This will be required because local procedural changes will have to be analyzed in terms of possible impact on the entire TOPS System. Each input-output location will be an integral part of the TOPS System and cannot operate as a separate entity.

A desirable training vehicle for the education of field personnel will be a railroad car equipped with TOPS input-output units and classroom space. This will provide an excellent mobile classroom for the field teams to conduct office-by-office training sessions.

IMPLEMENTATION OF CENTRAL AND REGIONAL FUNCTIONS

The central and regional functions of the TOPS System are those activities performed in:

1. Various bureaus specified for San Francisco.
2. Regional billing and cash application centers in San Francisco, Los Angeles, Houston and Portland.
3. Car Distributors' offices.
4. Dispatchers' offices.

In addition to programming these applications, it will be necessary to develop forms and master files, determine precise procedures for each area, and train the people involved. At least three men will be required to implement the central rating and revising functions and the regional freight billing and cash application functions. One man will be needed to implement the procedures for diversions, special accounts and traffic reporting. A team of two will work on implementation of activities in dispatchers' and car distributors' offices. One man will be required to supervise and co-ordinate card and forms design.

These personnel should be thoroughly experienced in the areas to which they are assigned and be available for training in October, 1962. These men will then be well trained in TOPS concepts.

EQUIPMENT

Implementation of the TOPS System will require a delivery schedule for the three categories of equipment used: Central Processor, Input-Output Units, and Regional Processors.

Using a contractual date of July 15, 1962 to estimate manufacturing schedules, the central processor will be ready for system test in Poughkeepsie in October, 1963. Shipment to Southern Pacific Company for installation and testing is scheduled for April, 1964. After this work is completed, the processing on the existing IBM 7074 will be shifted to the TOPS processor. The presently installed IBM 7074 will then be modified to make it compatible with the TOPS processor. During this period it will be possible to test data from remote locations and to check out TOPS programs. July, 1964 is the scheduled date for availability of the complete TOPS processor and completion of modification of the existing IBM 7074.

The input-output units specified for the TOPS System will be scheduled for delivery to achieve an orderly implementation program. By January, 1963, two engineering models will be available in San Francisco. They will be used to field test concepts and refine procedures. One will be an input-output unit for the operating procedures, and the other will be a waybilling and transmission set.

In October, 1963, waybilling sets will be delivered for installation at selected points. These sets will be used to prepare regular waybills and to generate punched paper tape for testing programs and refining procedures. During the period of preliminary testing, the paper tape will not be transmitted. It will be sent to San Francisco where it will be used to test programs and provide analytical data.

By January, 1964, operating input-output units will be installed at selected yard offices to test and refine procedures. It will be possible to connect these operating units on local communications circuits to transmit cards and listings between points in the same yard. This will allow field refinement of procedures for those yards requiring more than one PICL file.

By June, 1964, all sets required for waybilling and on-line traffic office procedures on the Pacific Lines will be installed. An intermediate procedure will permit the use of current passing and manifest data in the TOPS System for car tracing. Additional operating units will also be available for field installation.

The balance of the units will be scheduled for delivery to coincide with the implementation schedule. Off-line traffic offices will be installed by January, 1965. Cutover of operating procedures on the Portland, Shasta, Sacramento and Salt Lake Divisions will be accomplished by March, 1965. The balance of the Pacific Lines and Pacific Electric units will be cutover by the end of 1965. All units on the Texas and Louisiana Lines will be installed and cutover early in 1966. The equipment for the SD & AE and the NWP will be scheduled for June, 1966.

Southern Pacific Company

The schedule for implementation of the regional procedures will require the installation of an IBM 1401 system in Los Angeles by July, 1964, and another one in Portland by January, 1965. Part time use of an IBM 1401 in San Francisco will be required by July, 1964. The IBM 1401 now installed in Houston will be needed on a part time basis for TOPS processing in January, 1966.

APPLICATION CUTOVER

Implementation of the various applications in the TOPS System will be scheduled to complete cutover of the major areas in accordance with the following time schedule:

WAYBILLING CYCLE

| | |
|---------------------------|-------------|
| Pacific Lines | July, 1964 |
| Pacific Electric | July, 1965 |
| Texas and Louisiana Lines | March, 1966 |
| SD & AE and NWP | June, 1966 |

CAR TRACING AND SPECIAL ACCOUNT REPORTING CYCLE

| | |
|---|---------------|
| Cutover Current Passing and Manifest Data | July, 1964 |
| Pacific Lines Traffic Offices | July, 1964 |
| Off-Line Traffic Offices | January, 1965 |
| Texas and Louisiana Lines Traffic Offices | January, 1966 |

FREIGHT BILLING AND CASH APPLICATION CYCLE

| | |
|---------------------------|-----------------|
| Pacific Lines | March, 1965 |
| Pacific Electric | September, 1965 |
| Texas and Louisiana Lines | May, 1966 |
| SD & AE and NWP | July, 1966 |

TRAIN MOVEMENT CYCLE

| | |
|---|-----------------|
| Pacific Lines | |
| Portland, Shasta, Sacramento and Salt Lake Div. | March, 1965 |
| Western Division, San Joaquin and Coast Div. | July, 1965 |
| Los Angeles Division | September, 1965 |
| Tucson and Rio Grande Divisions | December, 1965 |
| Pacific Electric | October, 1965 |
| Texas and Louisiana Lines | April, 1966 |
| SD & AE and NWP | August, 1966 |

INDUSTRIAL SERVICE CENTER CYCLE

| | |
|------------------------------------|-----------------|
| Pacific Lines and Pacific Electric | January, 1966 |
| Texas and Louisiana Lines | May, 1966 |
| SD & AE and NWP | September, 1966 |

CAR DISTRIBUTORS CYCLE

| | |
|------------------------------|----------------|
| Pacific Lines | |
| Portland Division | July, 1965 |
| Balance and Pacific Electric | February, 1966 |
| Texas and Louisiana Lines | July, 1966 |
| SD & AE and NWP | October, 1966 |

DEMURRAGE CYCLE

| | |
|---|----------------|
| Pacific Lines | |
| Portland, Shasta, Sacramento and Salt Lake Div. | November, 1965 |
| Balance and Pacific Electric | February, 1966 |
| Texas and Louisiana Lines | July, 1966 |
| SD & AE and NWP | October, 1966 |

Applications will be started and cutover as shown in the detailed schedule in Figure 8-1.

FIGURE 8-1 IMPLEMENTATION SCHEDULE

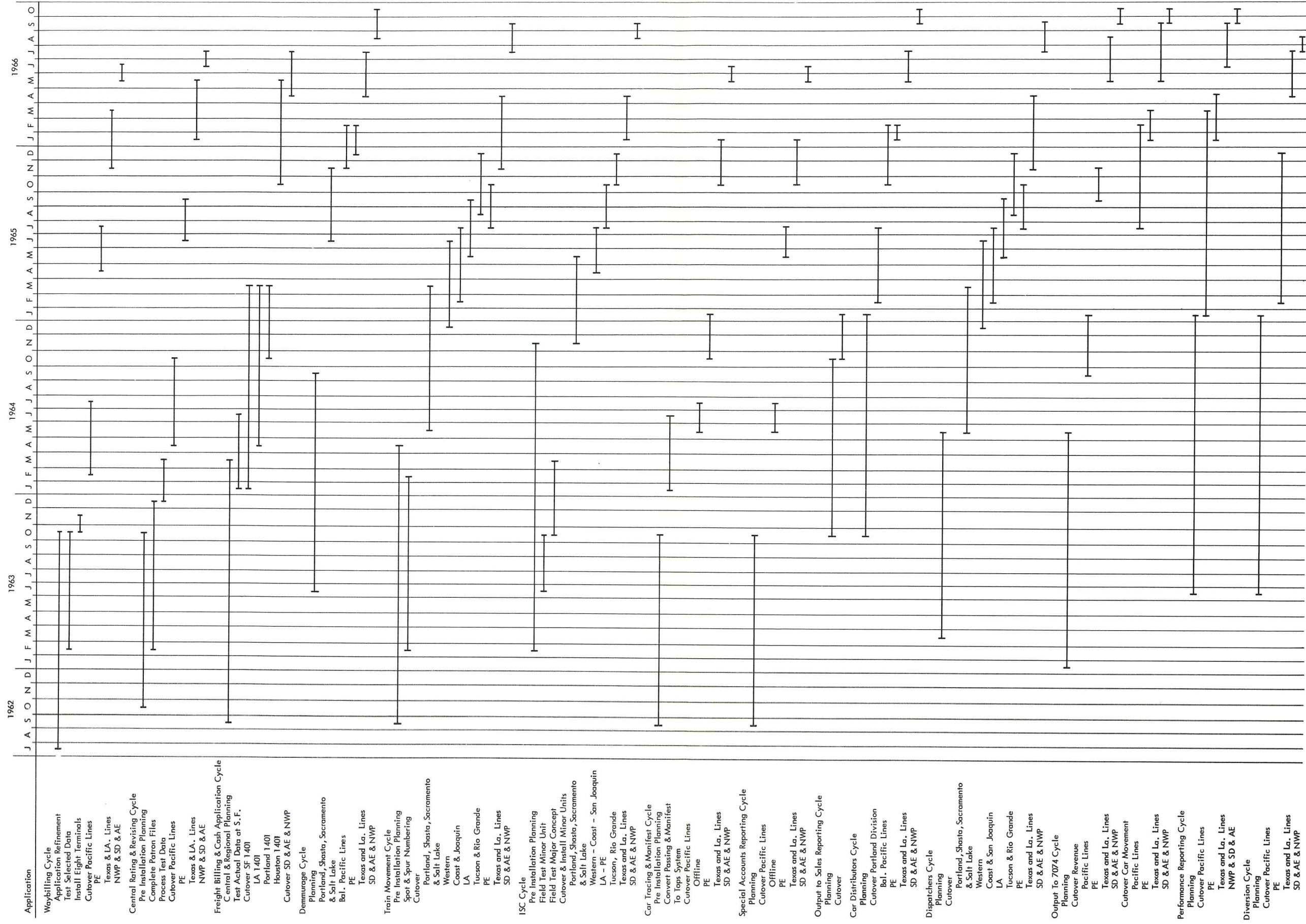

TABLE OF CONTENTS
RELIABILITY AND MAINTENANCE

| | Page |
|--|------|
| INPUT-OUTPUT LOCATIONS AND IBM CUSTOMER ENGINEERING LOCATIONS | 9-5 |

RELIABILITY AND MAINTENANCE

It is essential that both the equipment and procedures in a TELE-PROCESSING System such as TOPS perform reliably. Factors contributing to a high degree of equipment reliability are: maximum time between malfunctions of any unit or component, ability to detect a malfunction, minimum time to restore a unit to a proper operating condition, and provision for alternate units to be brought into operation promptly. The procedures have been designed to maximize reliability by transferring much of the clerical burden and the task of identifying data to the central processor. In addition, the central processor will check the completeness and accuracy of the data.

The Southern Pacific Company TELE-PROCESSING System has been designed to meet these requirements. Strict quality control of the selection of components from assembly through final testing assures reliability of each unit. Extensive error checking and diagnostic programming aid in detecting a malfunction and reducing the time required to service a unit. All major units are provided with standby support from at least one other unit. This support is put into operation in minimum time through centralized control and programmed switchover with little or no operator attention.

Reliability has been a prime consideration in the planning of every area of the TOPS System. In the central processor area, extensive error checking is provided in the circuits of the IBM 7074 system. Self-checking codes are used throughout the IBM High Speed Processor. The value of this checking is being further increased for the TOPS System through additional diagnostic circuits. In most cases, this added feature will allow the program to take corrective action automatically. Operator intervention will be required only for exceptional problems.

Parity checking is used extensively throughout the peripheral units of the central processor. This provides a high degree of assurance that data are being transferred correctly between the IBM 7074 and the peripheral equipment.

Parity checking is also provided for internal checking of data as it is assembled and processed by the IBM 7750 Programmed Transmission Control. In addition, messages received or transmitted by the IBM 7750 will be verified by a longitudinal check character. If an error occurs, the portion of the message in error will be corrected and automatically retransmitted.

The Duplex Console will provide the system operator with an indication of the operating condition of the central processor. The active processor and IBM 7750 Programmed Transmission Control will be required to signal the Duplex Console every few seconds of the satisfactory operation of the programs. If the Duplex Console does not receive this assurance, an operator will be notified through visual and audible means so that corrective action can be taken.

Switchover from one unit to another will be accomplished very rapidly. The system has been designed to provide for rapid switchover. For example, the IBM 7074 system can be switched at the central console area. Manual switches are provided on the Duplex Console to switch either IBM 7750 unit from one IBM 7074 to the

Southern Pacific Company

other. Provision has also been made to switch key tape units to the other IBM 7074 directly from the Duplex Console. After these two switches have been made, the supervisory program can be called into the standby IBM 7074 which will then be in full operation for the TOPS System.

A change from one IBM 7750 to another can also be performed at the Duplex Console by a manual switch. Switches are provided for changing the IBM 7074 from one IBM 7750 to the other. After the switches have been transferred, the program for the IBM 7750 may be entered and started. Communication lines may be selected by the program of either IBM 7750; no manual switching is required.

Each IBM 7074 has access to both IBM 7631 File Control Units. No switchover time is involved because the program in the central processor can automatically use either or both units.

There are four IBM 1301 Disk Storage Units (files) in the TOPS System. Three are required for storage of data and the fourth unit provides emergency back-up for the most active records. Data is distributed through these files in a manner that allows frequently-used records to be available in two files. If one unit becomes unavailable, the IBM 7074 program will automatically access the record from the back-up file with no loss in time. Emergency back-up for the less active records is provided by magnetic tape.

When the central processor is not actively engaged in handling messages, the supervisory program can run diagnostic programs to test various logical units and operations of the IBM 7074 system. This provides another means of detecting any marginal malfunctions promptly; if any occur, the operator will be notified. Once notified, the operator may initiate the corrective action.

Reliability has also been a prime consideration in remote areas, both from the component and procedural points of view. Longitudinal Redundancy Checking is used extensively as a means of checking the validity of transmitted messages either from the central processor to the I/O unit, or from the I/O unit to the central processor. In general, the transmitting unit will periodically request an LRC check from the receiving unit. The IBM 7750 will monitor input and output for LRC comparison errors. Transmission is interrupted until an acknowledgement that the transmission was successful is received. As long as no error occurs, transmission will be resumed upon receipt of the acknowledgement. If the acknowledgement is not received within one second, a re-send indicator is turned on and the transmission will be repeated. The IBM 7750 will be programmed so that if three attempts are unsuccessful, the operator will be notified to initiate corrective procedures.

Specifically, the various I/O units will use the LRC in the following manner:

After the card reader completes reading each card, a verify character is generated and inserted into the message. After the data is entered into the central processor, a check character is generated. This check character is a result of the data entered into the central processor from the card reader. The central processor compares the check character against the verify character read from the card reader. A like comparison indicates the data is valid; an unlike comparison indicates an error. If an error occurs, the card will automatically be re-read and sent to the central processor.

When paper tape is being prepared, the printer automatically produces a printed copy of the message for visual verification. Each carriage return of the printer will cause a verify character to be inserted into the paper tape; the verify character may also be inserted manually from the keyboard. When the paper tape is being read for transmission, the reader generates another verify character from the input data and compares it to the one read from the paper tape. A like comparison signifies valid data; an unlike comparison signifies an error. If an error occurs, an automatic back-up and re-read of the data block is accomplished.

The reliability of the clerical operations after the TOPS System has been installed will depend on the quality of the clerks and supervisors selected, the training provided and the extent of subsequent inspections. The TOPS System has been designed to simplify the clerical tasks so that minimum demands are made on the clerks. The implementation schedule makes provision for thorough training in the procedures. To achieve maximum reliability, however, it is most important that care is exercised in the selection of personnel and in the establishment of the organization that will ensure that the procedures are followed.

The chance of human error is reduced by transferring the task of identifying data entered into the TOPS System from clerks to the central processor. Also, through extensive checking, the central processor will generally determine the completeness and accuracy of incoming data.

Whenever a clerk has data to enter into the TOPS System for a particular car, he punches the information in a card that he has in his PICL or ISC files. This card was previously produced for this purpose by the central processor. It contains a reference number that identifies the record for that car in the central processor. It is not necessary for the clerk to punch Car Initial and Number in the card. For the cars handled outside of the areas served by the I/O units, all data entries on car movements are made with pickup and setout cards. Those cards have pre-punched reference numbers by which the central processor can identify the appropriate records. The exception to these procedures for identifying car movement data by a reference number is on receipt of a car at interchange. Here, Car Initial and Number is entered to open a record in the central processor. A record is setup, however, only after the check has been made against an abbreviated equipment register to determine if the Car Initial and Number is valid, and to verify the car type.

Before car records are updated, the central processor will verify that the incoming data is consistent with the information that is already in its records. For example, a car must depart from the same yard that it arrived in, or a car can only be released after it has been spotted. When incorrect or incomplete data is detected, responsible parties will be notified so that corrective action can be taken.

The procedures for entering waybill data were designed to take the burden off the operator and to facilitate error correction.

Whenever possible, the data entered into the TOPS System will contain some redundancy. The central processor will determine that the redundant data agrees with information already in its records.

Periodically, the random access files will be scanned by the central processor to eliminate any records that have been setup in error (such as an error in Car Initial and Number on interchange reporting).

Reliability must be, and is an essential part of the entire TELE-PROCESSING System. IBM equipment is built to the highest quality standards to assure maximum reliability. A regular preventive maintenance program can be established for all units of the TOPS System. Because of the duplexing provided at the central processor, preventive maintenance will be performed on units that may be released without interrupting the TOPS System. By this means, reliable operation is maintained.

Equally important is the quality of service which IBM will provide, both for emergency service and preventive maintenance. IBM Customer Engineers will be available to provide this prompt and efficient service to the central processor and to remote locations.

IBM is fully cognizant of the responsibility, importance, and magnitude of providing quality service for this and other TELE-PROCESSING Systems. In order to provide this vital service, the Customer Engineering locations are being rapidly expanded to provide early response time to calls from the growing network of input-output locations.

The following listings detail the contemplated input-output locations on the TOPS System with the related presently-manned service facilities.

Every effort has been extended in the design of the TOPS System to assure maximum reliability. IBM is confident that the functions of the TOPS System outlined in this report can be met with the proposed system.

Southern Pacific Company

INPUT-OUTPUT LOCATIONS AND IBM CUSTOMER ENGINEERING LOCATIONS

| Location of I/O Units | Type of I/O Unit | | IBM Service Location | CE Service Facility | Local or Miles Beyond Local Service Zone |
|----------------------------|------------------|-----|----------------------|---------------------|--|
| | 1001 | I/O | | | |
| PORTLAND DIVISION | | | | | |
| Portland | | x | Portland ✓ | Branch | Local |
| Salem | | x | Salem ✓ | Branch | Local |
| Albany | | x | Salem | Branch | 12 |
| Eugene | | x | Eugene | Sub Office | Local |
| Coos Bay | | x | Roseburg | Resident CE | 185 |
| Springfield | | x | Eugene | Sub Office | Local |
| Roseburg | | x | Roseburg | Resident CE | Local |
| Grants Pass | | x | Medford | Sub Office | 15 |
| Medford | | x | Medford | Sub Office | Local |
| Lebanon | x | | Salem | Branch | 23 |
| Hillsboro | x | | Portland | Branch | 18 |
| Wheeler-Tillamook | x | | Portland | Branch | 90 |
| McMinnville | x | | Portland | Branch | 37 |
| Toledo | x | | Corvallis | Resident CE | 35 |
| Corvallis | x | | Corvallis | Resident CE | Local |
| Coquille | x | | Roseburg | Resident CE | 210 |
| Crescent Lake | x | | Eugene | Sub Office | 75 |
| Oakridge | x | | Eugene | Sub Office | 26 |
| SHASTA DIVISION | | | | | |
| Gerber | | x | Redding | Resident CE | 26 |
| Dunsmuir | | x | Klamath Falls | Resident CE | 74 |
| Ashland | | x | Medford | Sub Office | Local |
| Klamath Falls | | x | Klamath Falls | Resident CE | Local |
| Chemault | x | | Klamath Falls | Resident CE | 56 |
| Redding | x | | Redding | Resident CE | Local |
| Mt. Shasta | x | | Klamath Falls | Resident CE | 68 |
| Montague | x | | Medford | Sub Office | 53 |
| Alturas | | x | Klamath Falls | Resident CE | 110 |
| Wendel | x | | Reno ✓ | Branch | 75 |
| Weed | x | | Klamath Falls | Resident CE | 59 |
| SACRAMENTO DIVISION | | | | | |
| Sacramento | | x | Sacramento ✓ | Branch | Local |
| Roseville | | x | Sacramento | Branch | 5 |
| Marysville | x | | Marysville | Resident CE | Local |
| Placerville | x | | Aerojet | Resident CE | 10 |
| Woodland | x | | Sacramento | Branch | 4 |

| Location of I/O Units | Type of I/O Unit | | IBM Service Location | CE Service Facility | Local or Miles Beyond Local Service Zone |
|---------------------------|------------------|-----|----------------------|---------------------|--|
| | 1001 | I/O | | | |
| SALT LAKE DIVISION | | | | | |
| Ogden | | x | Ogden | Sub Office | Local |
| Sparks | | x | Reno | Branch | Local |
| Fernley | | x | Reno | Branch | 20 |
| Carlin | | x | Ely | Resident CE | 195 |
| Mina | x | | Reno | Branch | 148 |
| Imlay | x | | Reno | Branch | 104 |
| Wells | x | | Ely | Resident CE | 122 |
| Reno | | x | Reno | Branch | Local |
| WESTERN DIVISION | | | | | |
| Hayward | x | | Oakland | Branch | Local |
| Mulford | x | | Oakland | Branch | Local |
| Newark | x | | Oakland | Branch | Local |
| Niles | | x | Oakland | Branch | Local |
| Martinez | | x | Oakland | Branch | Local |
| Port Chicago | | x | Oakland | Branch | Local |
| Tracy | | x | Tracy | Resident CE | Local |
| Lodi | | x | Stockton | Sub Office | Local |
| Stockton | | x | Stockton | Sub Office | Local |
| Modesto | | x | Modesto | Resident CE | Local |
| Oakland | | x | Oakland | Branch | Local |
| Milpitas | x | | Oakland | Branch | Local |
| Rodeo | x | | Oakland | Branch | Local |
| Pittsburg | x | | Oakland | Branch | Local |
| East Pleasanton | x | | Oakland | Branch | Local |
| Lombard-Napa Jct. | | x | Oakland | Branch | Local |
| Suisun | x | | Oakland | Branch | Local |
| Los Banos | x | | Merced | Resident CE | 15 |
| Mendota | x | | Fresno | Branch | 20 |
| Merced | x | | Merced | Resident CE | Local |
| COAST DIVISION | | | | | |
| San Luis Obispo | | x | San Luis Obispo | Resident CE | Local |
| Salinas | | x | Salinas | Sub Office | Local |
| Watsonville Jct. | | x | Santa Cruz | Resident CE | Local |
| San Jose | | x | San Jose | Branch | Local |
| Bayshore | | x | Burlingame | Sub Office | Local |
| Mission Bay | | x | San Francisco | Branch | Local |
| South City | | x | Burlingame | Sub Office | Local |
| San Francisco | | x | San Francisco | Branch | Local |

Southern Pacific Company

| Location of I/O Units | Type of I/O Units | | IBM Service Location | CE Service Facility | Local or Miles Beyond Local Service Zone |
|-----------------------------|-------------------|-----|----------------------|---------------------|--|
| | 1001 | I/O | | | |
| Lompoc | x | | San Luis Obispo | Resident CE | 24 |
| Guadalupe | | x | Santa Barbara | Sub Office | 31 |
| Santa Cruz | x | | Santa Cruz | Resident CE | Local |
| Gilroy | x | | San Jose | Branch | 14 |
| Sunnyvale | x | | San Jose | Branch | Local |
| Redwood | x | | Palo Alto | Resident CE | Local |
| SAN JOAQUIN DIVISION | | | | | |
| Mojave | | x | Bakersfield | Sub Office | 45 |
| Bakersfield | | x | Bakersfield | Sub Office | Local |
| Fresno | | x | Fresno | Branch | Local |
| Famoso | x | | Bakersfield | Sub Office | 13 |
| Delano | x | | Bakersfield | Sub Office | 21 |
| Jovista | x | | Bakersfield | Sub Office | 29 |
| Porterfield | x | | Visalia | Resident CE | 15 |
| Sanger | x | | Fresno | Branch | 4 |
| Coalinga | x | | Fresno | Branch | 55 |
| Huron | x | | Fresno | Branch | 32 |
| Hanford | x | | Visalia | Resident CE | 5 |
| Selma | x | | Fresno | Branch | Local |
| LOS ANGELES DIVISION | | | | | |
| El Centro | | x | Yuma | Resident CE | 52 |
| Indio | | x | Riverside | Branch | 60 |
| Colton | | x | Riverside | Branch | Local |
| Kaiser | | x | Riverside | Branch | Local |
| City of Industry | | x | Los Angeles East | Branch | Local |
| Tweedy | | x | Los Angeles East | Branch | Local |
| Gemco | | x | Burbank | Branch | Local |
| Oxnard | | x | Oxnard | Resident CE | Local |
| Santa Barbara | | x | Santa Barbara | Sub Office | Local |
| Yuma | | x | Yuma | Resident CE | Local |
| Los Angeles | | x | Los Angeles | | |
| | | | Downtown | Branch | Local |
| Los Angeles Harbor | | x | Long Beach | Branch | Local |
| Thermal | x | | Riverside | Branch | 69 |
| Pomona | x | | Los Angeles East | Branch | Local |
| Norwalk | x | | Los Angeles East | Branch | Local |
| Anaheim | x | | Santa Ana | Sub Office | Local |
| Santa Ana | x | | Santa Ana | Sub Office | Local |
| Dolores | x | | Santa Ana | Sub Office | Local |
| Wilmington | x | | Long Beach | Branch | Local |
| Riverside | x | | Riverside | Branch | Local |

| Location of I/O Units | Type of I/O Unit | | IBM Service Location | CE Service Facility | Local or Miles Beyond Local Service Zone |
|-----------------------------|------------------|-----|----------------------|---------------------|--|
| | 1001 | I/O | | | |
| RIO GRANDE DIVISION | | | | | |
| Tucumcari | | x | Amarillo | Sub Office | 99 |
| El Paso | | x | El Paso | Branch | Local |
| Lordsburg | | x | Las Cruces | Resident CE | 104 |
| Douglas | | x | Tucson | Sub Office | 104 |
| Deming | | x | Las Cruces | Resident CE | 44 |
| Carizzozo | x | | Roswell | Resident CE | 75 |
| Bisbee Jct. | x | | Tucson | Sub Office | 86 |
| Vaughn | x | | Roswell | Resident CE | 81 |
| TUCSON DIVISION | | | | | |
| Tucson | | x | Tucson | Sub Office | Local |
| Pheonix | | x | Pheonix | Branch | Local |
| Globe | x | | Pheonix | Branch | 85 |
| Bowie | x | | Tucson | Sub Office | 114 |
| Benson | x | | Tucson | Sub Office | 35 |
| Nogales | x | | Tucson | Sub Office | 50 |
| Willcox | x | | Tucson | Sub Office | 76 |
| Casa Grande | x | | Pheonix | Branch | 40 |
| Gila | x | | Pheonix | Branch | 50 |
| Mesa | x | | Pheonix | Branch | Local |
| Hayden | x | | Pheonix | Branch | 80 |
| SAN ANTONIO DIVISION | | | | | |
| San Antonio | | x | San Antonio | Branch | Local |
| Alice | | x | Corpus Christi | Branch | 29 |
| Edinburg | | x | Harlingen | Resident CE | 17 |
| Corpus Christi | | x | Corpus Christi | Branch | Local |
| Gregory | | x | Corpus Christi | Branch | Local |
| Eagle Pass | | x | San Antonio | Branch | 135 |
| Del Rio | | x | San Antonio | Branch | 140 |
| Valentine | | x | El Paso | Branch | 160 |
| Brownsville | | x | Harlingen | Resident CE | 16 |
| Gonzales | x | | San Antonio | Branch | 90 |
| Skidmore | x | | Corpus Christi | Branch | 30 |
| McAllen | x | | Harlingen | Resident CE | 20 |
| Harlingen | x | x | Harlingen | Resident CE | Local |
| Uvalde | x | | San Antonio | Branch | 77 |
| Spofford | x | | San Antonio | Branch | 118 |
| Sanderson | x | | San Antonio | Branch | 272 |

IBM TELE-PROCESSING Systems

| Location of I/O Units | Type of I/O Unit | | IBM Service Location | CE Service Facility | Local or Miles Beyond Local Service Zone |
|---|------------------|-----|-------------------------|---------------------------|--|
| | 1001 | I/O | | | |
| DALLAS - AUSTIN DIVISION | | | | | |
| Hearne | | x | Bryan | Resident CE | 5 |
| Ennis | | x | Dallas | Branch | 25 |
| Fort Worth | | x | Fort Worth | Branch | Local |
| Dallas | | x | Dallas | Branch | Local |
| Austin | | x | Austin | Branch | Local |
| Waco | | x | Waco | Sub Office | Local |
| Sherman | | x | Sherman | Resident CE | Local |
| Dennison | | x | Sherman | Resident CE | Local |
| Brenham | x | | Houston | Branch | 55 |
| Corsicana | | x | Waco | Sub Office | 43 |
| Jacksonville | x | | Tyler | Branch | 14 |
| Giddings | x | | Austin | Branch | 40 |
| HOUSTON DIVISION | | | | | |
| Houston | | x | Houston | Branch | Local |
| Navigation | | x | Houston | Branch | Local |
| Chaney | | x | Houston | Branch | Local |
| Shreveport | | x | Shreveport | Branch | Local |
| Lufkin | | x | Lufkin | Resident CE | Local |
| Glidden | | x | Houston | Branch | 72 |
| Victoria | | x | Houston | Branch | 114 |
| Galveston | | x | Galveston | Branch | Local |
| Eagle Lake | | x | Houston | Branch | 50 |
| Pasadena | x | | Houston | Branch | Local |
| Nocogdoches | x | | Lufkin | Resident CE | 5 |
| Corrigan | x | | Lufkin | Resident CE | 10 |
| Wharton | x | | Houston | Branch | 39 |
| Yoakum | x | | Houston | Branch | 106 |
| New Gulf | x | | Houston | Branch | 49 |
| LAFAYETTE DIVISION | | | | | |
| Avondale | | x | New Orleans | Branch | Local |
| New Orleans | | x | New Orleans | Branch | Local |
| New Iberia | | x | Lafayette | Resident CE | 9 |
| Lafayette | | x | Lafayette | Resident CE | Local |
| Alexandria | | x | Alexandria | Resident CE | Local |
| Lake Charles | | x | Lake Charles | Resident CE | Local |
| Beaumont | | x | Beaumont | Branch | Local |
| Baytown | x | | Houston | Branch | 13 |
| Raceland Jct. | x | | Houston | Branch | 26 |
| Morgan City | x | | Lafayette | Resident CE | 52 |

Southern Pacific Company

| Location of I/O Units | Type of I/O Unit | | IBM Service Location | CE Service Facility | Local or Miles Beyond Local Service Zone |
|-----------------------|------------------|-----|----------------------|---------------------|--|
| | 1001 | I/O | | | |
| Baldwin | x | | Lafayette | Resident CE | 27 |
| Eunice | x | | Lafayette | Resident CE | 45 |
| Echo | x | | Beaumont | Branch | 12 |
| Shriever | | x | New Orleans | Branch | 40 |

NORTHWESTERN PACIFIC

| | | | | | |
|------------|---|---|----------|-------------|-------|
| Eureka | | x | Eureka | Resident CE | Local |
| Willits | | x | Eureka | Resident CE | 75 |
| Shellville | | x | Oakland | Branch | 15 |
| San Rafael | x | | Petaluma | Resident CE | 20 |
| Arcata | x | | Eureka | Resident CE | Local |
| Ft. Seward | x | | Eureka | Resident CE | 50 |
| Ukiah | x | | Petaluma | Resident CE | 70 |
| Healdsburg | x | | Petaluma | Resident CE | 20 |
| Petaluma | x | | Petaluma | Resident CE | Local |
| Santa Rosa | x | | Petaluma | Resident CE | Local |

PACIFIC ELECTRIC

| | | | | | |
|----------------|---|---|----------------------|--------|-------|
| Los Angeles PE | | x | Los Angeles Downtown | Branch | Local |
| Butte | | x | Los Angeles East | Branch | Local |
| Los Nietos | | x | Los Angeles East | Branch | Local |
| Long Beach | | x | Long Beach | Branch | Local |
| Baldwin Park | | x | Glendale | Branch | Local |
| Eighth Street | | x | Los Angeles Downtown | Branch | Local |
| El Segundo | | x | Santa Monica | Branch | Local |
| Watson | | x | Long Beach | Branch | Local |
| Graham | | x | Long Beach | Branch | Local |
| Torrance | x | | Long Beach | Branch | Local |
| Wingfoot | x | | Long Beach | Branch | Local |
| San Bernardino | x | | Riverside | Branch | Local |
| Hollywood | x | | Los Angeles Wilshire | Branch | Local |
| Culver City | x | | Santa Monica | Branch | Local |

SD & AE

| | | | | | |
|-----------|---|--|-----------|--------|-------|
| San Diego | x | | San Diego | Branch | Local |
|-----------|---|--|-----------|--------|-------|

| Location of I/O Units | Type of I/O Unit | | IBM Service Location | CE Service Facility | Local or Miles Beyond Local Service Zone |
|---|------------------|-----|-------------------------|---------------------------|--|
| | 1001 | I/O | | | |
| OFF-LINE TRAFFIC OFFICES | | | | | |
| Atlanta | | x | Atlanta | Branch | Local |
| Birmingham | | x | Birmingham | Branch | Local |
| Boston | | x | Boston | Branch | Local |
| Buffalo | | x | Buffalo | Branch | Local |
| Chicago | | x | Chicago | Branch | Local |
| Cincinnati | | x | Cincinnati | Branch | Local |
| Cleveland | | x | Cleveland | Branch | Local |
| Denver | | x | Denver | Branch | Local |
| Detroit | | x | Detroit | Branch | Local |
| Indianapolis | | x | Indianapolis | Branch | Local |
| Kansas City | | x | Kansas City | Branch | Local |
| Memphis | | x | Memphis | Branch | Local |
| Milwaukee | | x | Milwaukee | Branch | Local |
| Minneapolis | | x | Minneapolis | Branch | Local |
| New York | | x | New York | Branch | Local |
| Philadelphia | | x | Philadelphia | Branch | Local |
| Pittsburgh | | x | Pittsburgh | Branch | Local |
| St. Louis | | x | St. Louis | Branch | Local |
| Salt Lake City | | x | Salt Lake City | Branch | Local |
| Seattle | | x | Seattle | Branch | Local |
| Tulsa | | x | Tulsa | Branch | Local |
| Washington, D. C. | | x | Washington, D. C. | Branch | Local |
| Winston-Salem | | x | Winston-Salem | Branch | Local |

TABLE OF CONTENTS

APPENDIX

| | Page |
|--------------------------------|------|
| USE OF BASIC SYSTEM STATISTICS | A-1 |
| TRAFFIC OFFICES STATISTICS | A-1 |
| ACCOUNTING STATISTICS | A-2 |
| OPERATING STATISTICS | A-2 |
| Operating Flow Diagrams | A-2 |
| Tri-Hourly Train Statistics | A-3 |
| Southern Pacific Time Tables | A-3 |
| Wheel Report Summaries | A-3 |
| Summary of Forms 2619 | A-4 |
| Interchange Statistics | A-4 |
| SPECIAL REPORTS | A-5 |
| SPECIAL STUDIES | A-5 |
| TIME DISTRIBUTIONS | A-6 |
| CAR CLEANING | A-6 |
| SPOTTING AND PULLING | A-6 |

LIST OF ILLUSTRATIONS

| | Page |
|-----------------------------------|----------------|
| Freight Traffic Office Statistics | A-7 to A-9 |
| Accounting Data Entry Points | A-10 to A-22 |
| Operating Flow Diagrams | A-23 to A-54 |
| Tri-Hourly Train Statistics | A-55 to A-76 |
| Summary of Forms 2619 | A-77 to A-82 |
| Interchange Statistics | A-83 to A-104 |
| Carloading Statistics | A-105 to A-108 |

APPENDIX

USE OF BASIC SYSTEM STATISTICS

Some Basic statistics used to design the TOPS System are shown in this Appendix. These and literally hundred of other statistics were used to design the System. In some cases, special studies were developed for yards that illustrated car volumes moving within the yard and associated industrial zones.

While the volume of a given event is important, the time distribution of the event is equally important. In the case of train movement data, the time was directly associated with the statistics provided. However, for such items as car releases, traffic office statistics, or car orders, a time distribution of the information was developed.

The statistics and information were used to develop the volumes and time distributions for individual I/O unit locations, IBM 1001 locations, and for the data center at San Francisco. In the latter case, the time difference for the time zones was incorporated, and data was time shifted as much as three hours in the traffic area, and as much as two hours in the operating area.

Traffic Office Statistics

The basic statistics were developed by location as shown in this appendix. This data is the sum of the characters for the various messages that will be sent or received. For each location, the various messages were developed and distributed in time according to the following criteria:

1. Tracing Requests:

| | |
|------------------------|-----|
| 9:00 a.m. - 11:00 a.m. | 65% |
| 11:00 a.m. - 4:00 p.m. | 15% |
| 4:00 p.m. - 5:00 p.m. | 20% |

2. Manifest Requests, Diversion Requests, and Expedite Requests:

| | |
|------------------------|-----|
| 9:00 a.m. - 11:00 a.m. | 55% |
| 11:00 a.m. - 4:00 p.m. | 30% |
| 4:00 p.m. - 5:00 p.m. | 15% |

3. Waybill Requests, Historical Tracing Requests, and Arrival and Delivery Requests:

Flat distribution for 8 hours.

4. Bad Order Notices, Back in Service Notices, Arrival and Delivery Notices:

Uniform over 24 hours.

5. Special Account Car Reports:

These reports will be divided into two sections. Reports on cars that have been reported the previous day will be provided as required. New car reports will be uniformly distributed during the eight hour day.

ACCOUNTING STATISTICS

The basic data for the assignment of station and interchange volumes to way-billing locations is shown in this appendix together with the totaled volumes of "Total Carloads Forwarded" and "Piggyback Forwarded" volumes as assigned.

Monthly carload figures (forwarded and interchange received) were converted to daily volumes by dividing by 22 to develop daily waybill volumes.

Interline received waybilling per shift was assumed to be uniform. All forwarded traffic was assumed to be billed on the second shift. Empty car bills would be prepared for 5% of all received carloads; advance-only bills would be prepared for 20% of the waybills. Three waybills would be prepared for each piggyback carload.

Local waybill volumes were obtained by using system averages. Thus, between 48% and 51% of the carloads forwarded for June, 1960 are local; the remainder are inter-line forwarded.

OPERATING STATISTICS

The following is a brief description of statistics and information gathered that will illustrate the basic technique employed to develop the data volumes at I/O units in yards.

In the System Analysis Section, the data developed for Dallas Street, El Paso is presented. A statistical data sheet similar to it was prepared for each I/O unit location and IBM 1001 location.

Operating Flow Diagrams

These diagrams provided the following information:

1. Crew on-off duty points.
2. Train origination, termination, turn-around, and crew change locations.
3. Special tracks or areas within yards, such as icing, TOFC, and rip tracks.

4. Interchange locations.
5. Industrial zones with yards.
6. Shifts that switchers work zones (in some cases).

Tri-Hourly Train Statistics (October 1960)

This data was developed by station, for the eight 3-hour periods of a day. It summarizes, for a month, the number of:

1. Local thru originations.
2. Local thru terminations.
3. Thru train originations.
4. Thru train terminations.
5. Thru train arrivals for crew changes.

These train statistics were used to obtain daily volumes of train events assigned to the I/O unit locations and to IBM 1001 locations, including local trains which will operate on switch-lists. (Train dispatcher volumes for train calls were also developed from these train statistics.) These monthly totals for the Pacific Lines and the Texas and Louisiana Lines (October, 1960) are illustrated in this appendix. The statistics used to obtain daily volumes of train events for the Pacific Lines were those for June, 1961.

SOUTHERN PACIFIC TIME TABLES

The time tables were used to obtain "East" and "West" directions for interpretation of wheel report statistics. In addition, scheduled trains were used to clarify the tri-hourly train statistics and pinpoint extra trains.

Wheel Report Summaries

Wheel Report Summaries were developed by station for the month of October, 1960. The following volumes were accumulated for each station:

1. Number of loaded cars arriving on eastbound local trains.
2. Number of loaded cars departing on eastbound local trains.
3. Number of loaded cars arriving on westbound local trains.
4. Number of loaded cars departing on westbound local trains.
5. Number of empty cars arriving on eastbound local trains.
6. Number of empty cars departing on eastbound local trains.
7. Number of empty cars arriving on westbound local trains.
8. Number of empty cars departing on westbound local trains.

Southern Pacific Company

These volumes (1-8) were also accumulated for thru trains.

These wheel report statistics were used to develop the following volumes for the trains assigned in the tri-hourly train statistics:

1. Mean number of cars per train - local originations.
2. Mean number of cars per train - thru originations.
3. Mean number of cars per train - local terminations.
4. Mean number of cars per train - thru terminations.
5. Mean number of cars set out by a thru train during the next segment of the run.
6. Mean number of cars picked up by a thru train during the last segment of the run.
7. Mean number of cars set out in the yard for thru trains changing crews.
8. Mean number of cars picked up in the yard for thru trains changing crews.

SUMMARY OF FORMS 2619 - COMPARATIVE STATEMENT OF BUSINESS HANDLED 1960 (BY MONTH)

The statistics shown were used to develop the following daily volumes by dividing by 22:

1. The number of Advance Arrival Notices received at an ISC I/O unit was calculated to be the sum of the carloads received within the ISC area.
2. The number of cars ordered by patrons was taken as the number of carloads forwarded within the ISC area.
3. The number of loaded and empty cars released by patrons was calculated as the sum of the carloads received and carloads forwarded within an ISC area.
4. The number of cars moved into a yard by switchers operating in industrial zones was developed as the sum of the carloads received and the carloads forwarded at that location.

INTERCHANGE STATISTICS

Also included in this appendix are the interchange volumes for the Pacific Lines (June 1960) and the Texas and Louisiana Lines (January 1961). In addition to these volumes, copies of the forms S-925 were available for the Texas and Louisiana Lines for each month of 1960. Volumes for the Pacific Electric Railway were provided as well as October 1960 statistics for the Pacific Lines.

SPECIAL REPORTS

Reports were also compiled for the following statistics:

- Cars cleaned
- Cars iced
- Cars weighed
- Cars bad ordered
- Cars diverted
- Cars held - in some yards
- Switchers on duty by shift
- Switchers assigned to industry zones by shift - Pacific Lines

SPECIAL STUDIES

Studies were made of complex yards and the Pacific Electric Railway to estimate transfer volume. Yard studies were provided for locations such as:

- El Paso
- Englewood - Chaney - Navigation
- Eugene
- Los Angeles
- Miller - Dallas
- Oakland
- Tucson
- Roseville
- San Francisco
- San Jose

Data for switcher operation during the perishable season in the Imperial Valley (El Centro area) was also gathered.

Spotting or pulling volumes for switcher operation (including cars re-spotted or pulled) were, in general, calculated as follows:

$$\begin{aligned} \text{Number of cars} &= 1.5 \times (\text{carloads received}) + \\ & 1.5 \times (\text{dead freight carloads forwarded} + \\ & \quad \text{livestock carloads forwarded}) + \\ & 2.5 \times (\text{perishable carloads forwarded}) \end{aligned}$$

The number of cars pulled into the yard was calculated as the sum of the carloads forwarded and carloads received.

TIME DISTRIBUTIONS

The following is the estimated time distribution for car orders:

| TIME ENTERED | PERCENT OF TOTAL ORDERS |
|----------------------------|-------------------------|
| 8:00 a.m. - 12:00 Noon | 35% |
| 12:01 p.m. - 3:00 p.m. | 40% |
| 3:01 p.m. - 4:00 p.m. | 10% |
| 4:01 p.m. - 12:00 Midnight | 10% |
| 12:01 a.m. - 8:00 a.m. | 5% |

The following is the estimated time when car releases would be entered into the system.

| TIME ENTERED | PERCENT OF TOTAL RELEASE |
|----------------------------|--------------------------|
| 7:01 a.m. - 8:00 a.m. | 15% |
| 8:01 a.m. - 12:00 Noon | 10% |
| 12:01 p.m. - 2:00 p.m. | 15% |
| 2:01 p.m. - 4:00 p.m. | 30% |
| 4:01 p.m. - 6:00 p.m. | 15% |
| 6:01 p.m. - 12:00 Midnight | 12 1/2% |
| 12:01 a.m. - 7:00 a.m. | 2 1/2% |

CAR CLEANING

One shift is on duty at all cleaning points. It is assumed cars are cleaned during the period from 7:00 a.m. to 4:00 p.m.; however, grading, which constitutes an inspection and subsequent assignment of a grade indicating the commodities the equipment can handle, were assumed to enter the system with the following time allocation:

- 10% between 7:00 a.m. - 10:00 a.m.
- 50% between 10:01 a.m. - 1:00 p.m.
- 40% between 1:01 p.m. - 4:00 p.m.

SPOTTING AND PULLING

Spotting and pulling data were assumed to be entered into the system during the two-hour period prior to shift change.

| SHIFT | % OF TOTAL DATA ENTERED | | |
|-----------------------|-------------------------|-----|-----|
| | 1 | 2 | 3 |
| TOTAL CARS SPOTTED | 20% | 20% | 60% |
| TOTAL CARS PULLED | 20% | 60% | 20% |
| CARS PULLED INTO YARD | 20% | 60% | 20% |

TRAFFIC OFFICE STATISTICS

This listing presents the character volume estimate for I/O units at Freight Traffic Offices in the TOPS System. Figures are given for Car Arrivals, Car Departures, Tracing Volumes, and estimated daily character input and output.

FREIGHT TRAFFIC I/O UNIT VOLUME ESTIMATES

| <u>I/O Unit Location</u> | <u>Cars Arriving</u> | <u>Cars Departing</u> | <u>Tracing Volume</u> | <u>Estimated Daily Characters Input</u> | <u>Estimated Daily Characters Output</u> |
|---------------------------|----------------------|-----------------------|-----------------------|---|--|
| Eugene | 139 | 415 | 17 | 7,385 | 22,625 |
| Medford | 40 | 316 | 17 | 6,092 | 12,675 |
| Portland | 214 | 157 | 12 | 5,550 | 35,175 |
| Salem | 151 | 285 | 11 | 6,268 | 22,695 |
| Seattle (Off line) | 216 | 182 | 85 | 7,400 | 42,090 |
| Bakersfield | 14 | 101 | 18 | 4,288 | 13,690 |
| Fresno | 52 | 180 | 15 | 5,035 | 21,025 |
| Klamath Falls | 25 | 111 | 25 | 4,572 | 15,765 |
| Oakland | 332 | 577 | 65 | 9,258 | 71,425 |
| Reno | 24 | 85 | 7 | 3,956 | 13,035 |
| Sacramento | 83 | 243 | 25 | 5,910 | 27,875 |
| Salt Lake City (Off line) | 71 | 162 | 35 | 5,426 | 23,460 |
| San Francisco | 200 | 344 | 1,180 | 33,314 | 130,650 |
| San Jose | 60 | 110 | 18 | 4,574 | 18,550 |
| Stockton | 58 | 144 | 25 | 5,000 | 20,565 |
| Eureka (NWP) | | | | | |
| Los Angeles | 620 | 574 | 947 | 31,860 | 164,700 |
| Riverside | 92 | 202 | 48 | 6,138 | 28,400 |
| Wilmington | 147 | 172 | 78 | 6,840 | 34,475 |
| Phoenix | 166 | 150 | 228 | 10,130 | 46,430 |
| Tucson | 105 | 97 | 98 | 4,500 | 28,205 |
| El Paso | 207 | 177 | 122 | 5,682 | 43,720 |
| Beaumont | 104 | 150 | 52 | 5,865 | 27,290 |
| Corpus Christi | 76 | 59 | 38 | 4,693 | 12,496 |
| Harlingen | 22 | 32 | 11 | 3,609 | 10,520 |

FREIGHT TRAFFIC I/O UNIT VOLUME ESTIMATES

(continued)

| <u>I/O Unit Location</u> | <u>Cars Arriving</u> | <u>Cars Departing</u> | <u>Tracing Volume</u> | <u>Estimated Daily Characters Input</u> | <u>Estimated Daily Characters Output</u> |
|--------------------------|----------------------|-----------------------|-----------------------|---|--|
| Houston | 671 | 611 | 335 | 18,640 | 125,500 |
| San Antonio | 134 | 118 | 67 | 11,838 | 29,670 |
| Dallas | 129 | 100 | 65 | 5,878 | 28,180 |
| Lake Charles | 246 | 223 | 125 | 8,790 | 49,920 |
| New Orleans | 178 | 146 | 89 | 5,218 | 36,890 |
| Atlanta | 113 | 34 | 6 | 3,946 | 18,935 |
| Birmingham | 83 | 41 | 25 | 4,290 | 18,085 |
| Chicago | 185 | 188 | 94 | 5,605 | 40,050 |
| Cincinnati | 55 | 55 | 25 | 4,467 | 15,895 |
| Cleveland | 51 | 52 | 30 | 4,337 | 15,710 |
| Denver | 38 | 39 | 30 | 4,170 | 13,820 |
| Detroit | 61 | 98 | 60 | 5,427 | 21,200 |
| Indianapolis | 36 | 20 | 15 | 3,669 | 11,565 |
| Kansas City | 168 | 103 | 16 | 4,987 | 28,400 |
| Memphis | 69 | 63 | 34 | 4,599 | 18,280 |
| Milwaukee | | | | | |
| Minneapolis | 60 | 36 | 30 | 4,251 | 15,785 |
| St. Louis | 76 | 137 | 35 | 5,250 | 22,685 |
| Tulsa | 41 | 57 | 4 | 3,743 | 13,040 |
| Winston-Salem | 85 | 35 | 18 | 4,093 | 17,225 |
| Boston | 46 | 22 | 11 | 3,644 | 12,315 |
| Buffalo | 39 | 28 | 10 | 3,636 | 11,880 |
| New York | 113 | 60 | 91 | 4,227 | 26,595 |
| Philadelphia | 50 | 35 | 59 | 4,849 | 16,945 |
| Pittsburgh | 32 | 61 | 6 | 3,777 | 12,530 |
| Washington | 39 | 21 | 15 | 3,693 | 11,900 |

Southern Pacific Company

ACCOUNTING DATA ENTRY POINTS

Data from agency stations and from non-agency interchange points will be entered at the data entry points specified in the following list. Where data for certain stations can be entered at more than one point, estimated percentages of the volume of entry to be assigned each point are shown.

TEXAS AND LOUISIANA LINES

| Interchange or Agency Station | Accounting Data Entry Point | | Interchange or Agency Station | Accounting Data Entry Point | | | |
|-------------------------------|-----------------------------|------------|-------------------------------|-----------------------------|-----|--------|-----|
| Dennison | Ennis | | Rosebud | Hearne | | | |
| Sherman | Ennis | | | | | | |
| McKinney | Ennis | | Waco | | | | |
| Plano | Ennis | | Marlin | | | | |
| Ferris | Ennis | | Bryan | Houston | 50% | | |
| Dallas | Miller | | Navasota | Hearne | 50% | | |
| Fort Worth | Fort Worth | | Caldwell | Austin | 35% | | |
| Midlothian | Fort Worth | | | Hearne | 35% | | |
| Wakahachie | Ennis | | | San Antonio | 30% | | |
| Ennis | Ennis | | Shreveport | Shreveport | | | |
| Corsicana | Corsicana | | Logansport | Shreveport | 50% | | |
| Mexia | Ennis Hearne | 30% 70% | Tenaha | | | | |
| Groesbeck | | | Garrison | | | Lufkin | 25% |
| Kosse | | | Nacagdoches | | | Miller | 25% |
| Bremond | | | Lufkin | | | | |
| Hearne | Hearne | | Diboll | Houston | 70% | | |
| Cameron | Hearne | | | Lufkin | 30% | | |

| Interchange or Agency Station | Accounting Data Entry Point | Interchange or Agency Station | Accounting Data Entry Point |
|-------------------------------|--|-------------------------------|---|
| Corrigan | Houston 70% Lufkin 30% | East Bernard | Houston 90% San Antonio 10% |
| Livingston | | Glidden | Glidden |
| Sheperd | | Weimar | San Antonio 35% Houston 35% Hearne 30% |
| Cleveland | | Schulenberg | |
| Crandell | Flatonia | | |
| Kaufman | Lufkin 35% Miller 35% Shreveport 30% | West Point | San Antonio 35% Houston 35% Hearne 30% |
| Athens | | Gonzales | |
| Jacksonville | | Luling | |
| Cushing | | Sequin | |
| Rusk | Miller | Converse | San Antonio |
| Palestine | | San Antonio | |
| Commerce | | Comfort | |
| Cooper | | Kerrville | |
| Paris | Houston | Floresville | San Antonio 60% Corpus Christi 20% Victoria 20% |
| Houston | | Karnes City | |
| Pasadena | | Kenedy | |
| La Porte | | Beeville | |
| Texas City | Hearne 50% Houston 50% | Skidmore | San Antonio 70% Victoria 20% Edinburg 10% |
| Galveston | | Mathis | |
| Waller | | Orange Grove | |
| Hempstead | | Alice | |
| Brenham | San Antonio 20% Houston 30% Hearne 20% Austin 30% | Premont | Edinburg 10% Victoria 20% |
| Gidings | | Falfurias | San Antonio 60% Corpus Christi 10% |
| Elgin | | Edinburg | Edinburg |
| Austin | | McAllen | |
| McNeil | Elsa | | |
| Burnett | Austin | Santa Rosa | Edinburg |
| Bertram | | Harlingen | |
| Marble Falls | | Brownsville | |
| Liano | | | |
| Eagle Lake | Eagle Lake | | |

| Interchange or Agency Station | Accounting Data Entry Point | | Interchange or Agency Station | Accounting Data Entry Point | |
|-------------------------------|-----------------------------|----------------|-------------------------------|-----------------------------|-----|
| Corpus Christi | Corpus Christi | | Guy | Houston | |
| Aransas Pass | | | Dayton | | |
| Rockport | | | Bayton | | |
| Gregory | | | Liberty | Beaumont | 40% |
| Taft | | Corpus Christi | 25% | Houston | 60% |
| Sinton | Victoria | 25% | Devers | | |
| Victoria | San Antonio | 25% | Beaumont | Beaumont | |
| Pt. Lavaca | Edinburg | 25% | Chaison | Beaumont | |
| Goliad | Victoria | | Port Arthur | Beaumont | |
| Cuero | | | Kountze | | |
| Nixon | San Antonio | 50% | Warren | | |
| Yorktown | Victoria | 50% | Woodville | Lufkin | 30% |
| Yoakum | | | Colmesneil | Beaumont | 70% |
| Shiner | Hearne | 50% | Zavalla | | |
| Moulton | Victoria | 50% | Orange | Beaumont | |
| Edna | Hearne | 25% | Vinton | | |
| Louise | San Antonio | 25% | Sulfur | Lake Charles | 50% |
| El Campo | Houston | 25% | Lake Charles | Beaumont | 50% |
| Wharton | Victoria | 25% | Lake Arthur | Lake Charles | |
| New Gulf | | | Lake Arthur | Lake Arthur | |
| Bay City | Houston | 80% | De Ridder | Lake Charles | |
| Blessing | Victoria | 20% | Iowa | | |
| Palacios | | | Welsh | | |
| Rosenberg | Victoria | 15% | Jennings | Lake Charles | 50% |
| Sugar Land | San Antonio | 15% | Mermenthau | Lafayette | 50% |
| Needville | Houston | 70% | Midland | | |
| Long Point | Houston | 80% | Iota | | |
| | Victoria | 20% | Eunice | | |
| | | | Gueydan | New Iberia | 35% |
| | | | Kaplan | Lake Charles | 35% |
| | | | Abbeville | Lafayette | 30% |

| Interchange or Agency Station | Accounting Data Entry Point | | Interchange or Agency Station | Accounting Data Entry Point | |
|-------------------------------|-----------------------------|-----|-------------------------------|-----------------------------|-----|
| Erath | | | Raceland | | |
| Crowley | | | Mathews | | |
| Rayne | Lake Charles | 50% | | Avondale | 80% |
| Duson | Lafayette | 30% | Lockport | Lafayette | 20% |
| Scott | | | Paradis | | |
| Layfayette | Lafayette | | Avondale | | |
| Carencro | | | New Orleans | Avondale | |
| Sunset | | | LaCoste | | |
| Opelusas | | | Hondo | | |
| Washinton | Lafayette | | D'Hannis | | |
| Eola | | | Sabinal | | |
| Cheneyville | | | Knippa | San Antonio | 80% |
| Alexandria | Beaumont | | Uvalde | El Paso | 20% |
| Arnaudville | | | Cline | | |
| Beauxbridge | Lafayette | | Spofford | | |
| St. Martinsville | | | | | |
| Broussard | Lafayette | 50% | Eagle Pass | Eagle Pass | |
| | Avondale | 50% | | | |
| New Iberia | New Iberia | | Del Rio | | |
| Jeanerette | | | Comstock | | |
| Baldwin | | | Langtry | | |
| Franklin | | | Dryden | | |
| Bayousale | Layfayette | 40% | Sanderson | | |
| | Avondale | 60% | Marathon | | |
| Patterson | | | Alpine | | |
| Berwick | | | Maria | | |
| Morgan City | | | Valentine | San Antonio | 80% |
| Beouf | | | Sierra Blanca | El Paso | 20% |
| Schreiver | | | Tornillo | | |
| Houma | | | Fabens | | |
| Thibodaux | Schreiver | | Clint | | |
| Napoleonville | | | El Paso | El Paso | |
| La Fourche | | | | | |

SOUTHERN PACIFIC, PACIFIC LINES

| Interchange or Agency Station | Accounting Data Entry Point | | Interchange or Agency Station | Accounting Data Entry Point | | | |
|-------------------------------|-----------------------------|------------|-------------------------------|-----------------------------|---------------------------------|--|------------|
| Tillamook | Brooklyn Eugene | 40% 60% | Lebanon | Eugene | | | |
| Garibaldi | | | Halsey | | | | |
| Wheeler | | | Junction City | | | | |
| Hillsboro | | | Eugene | | | | |
| Forest Grove | | | Powers | | | | |
| Seghers | | | Myrtle Point | | | | |
| Carlton | | | Coquille | | | | |
| East Portland | | | Brooklyn | | | | Coos Bay |
| Portland | | | | | | | North Bend |
| Brooklyn | | | | | | | Reedsport |
| Newberg | Brooklyn Eugene | 40% 60% | Cushman | | | | |
| McMinnville | | | Mapleton | | | | |
| Willamina | | | Swiss Home | | | | |
| Sheridan | | | Veneta | | | | |
| Clackamas | Brooklyn | | Cottage Grove | | | | |
| Oregon City | | | Drain | | | | |
| Canby | | | Oakland, Ore. | | | | |
| Woodburn | | | Sutherlin | | | | |
| Brooks | | | Roseburg | | | | |
| Salem | | | Myrtle Creek | | | | |
| Mount Angel | | | Riddle | | | | |
| Silverton | | | Springfield | | | | |
| Oswego | | | Oakridge | | Klamath Falls | | |
| Dallas | | | Chemult | | Klamath Falls 90% Eugene 10% | | |
| Independence | Chiloquin | | | | | | |
| Toledo | Eugene | | Glendale | Medford | | | |
| Corvallis | | | Grants Pass | | | | |
| Monroe | | | Medford | | | | |
| Albany | | | | | | | |
| West Strayton | | | | | | | |

| Interchange or Agency Station | Accounting Data Entry Point | | Interchange or Agency Station | Accounting Data Entry Point | |
|-------------------------------|---------------------------------|---|----------------------------------|---------------------------------|--|
| Ashland | Klamath Falls Gerber | 60% 40% | Corning | Gerber | |
| Hornbrook | | | Hamilton | | |
| Montague | | | Orland | Roseville 70% Sacramento 30% | |
| Weed | | | Willows | | |
| Mount Shasta | Gerber 80% Klamath Falls 20% | Williams | | | |
| Dunsmuir | Woodland | | | | |
| Dorris | Klamath Falls | | Polk | Sacramento | |
| McDoel | | Grimes | Gerber | | |
| Tule Lake | | Sacramento | | | |
| Merrill | | Folsom | Sacramento | | |
| Canby, Calif. | Reno | | Placerville | | |
| Lakeview | | Walnut Grove | Roseville | | |
| Alturas | | Davis | | | |
| Likely | | Dixon | | | |
| Redding | Gerber 80% Klamath Falls 20% | 80% 20% | Winters | Roseville 60% Oakland 40% | |
| Anderson | | | Suisun Fairfield | | |
| Cottonwood | | | Calistoga | | |
| Red Bluff | | | St. Helena | | |
| Gerber | Roseville Gerber | Schellville Lombard | Schellville | Schellville | |
| Tehama | | | | | |
| Chico | | | Roseville 70% Schellville 30% | | |
| Gridley | | | Gerber 10% | | |
| Oroville | Roseville Crockett | Roseville 40% Tracy 30% Oakland 30% | Martinez | | |
| Marysville | | | | | |
| Lincoln | | | Selby | | |
| Colfax | | | Rodeo | | |
| Roseville | Roseville | Oakland | Richmond | | |
| Auburn | | | Berkeley | | |
| | | | Oakland | | |
| Truckee | | | Roseville 50% Reno 50% | Alameda | |

Southern Pacific Company

IBM TELE-PROCESSING Systems

| Interchange or Agency Station | Accounting Data Entry Point | | Interchange or Agency Station | Accounting Data Entry Point | |
|-------------------------------|-----------------------------|---------|-------------------------------|-----------------------------|-------|
| Oakland, 5th St. | Oakland | | Lodi | Roseville | 70% |
| Fruitvale | | | | Stockton | 10% |
| Elmhurst | | | | Fresno | 10% |
| San Leandro | | | | Tracy | 10% |
| Avon | | | | Stockton | |
| McAvoy | Tracy | 70% | Oakdale | Stockton | |
| | | Oakland | 30% | Patterson | |
| Port Chicago | Tracy | | Newman | | |
| Pittsburg | | | Los Banos | | Tracy |
| Brentwood | Tracy | | Dos Palos | Fresno | 10% |
| Tracy | Tracy | | Firebaugh | | |
| | Oakland | 50% | Mendota | | |
| | San Jose | 30% | Manteca | | |
| Mulford | Tracy | 10% | Modesto | | |
| | San Francisco | 10% | | Roseville | 70% |
| | Oakland | 60% | Turlock | Stockton | 10% |
| Hayward | San Jose | 30% | | Tracy | 10% |
| | Tracy | 10% | Merced | Fresno | 10% |
| Niles | Niles | | Chowchilla | | |
| | San Jose | 30% | Madera | | |
| Alvarado | Tracy | 30% | Fresno | Fresno | |
| | Oakland | 40% | | Tracy | 90% |
| | Oakland | 20% | Helm | Fresno | 10% |
| Newark | Tracy | 40% | Fowler | | |
| | San Jose | 40% | Selma | | |
| | Tracy | 40% | Kingsburg | | |
| Milpitas | San Jose | 30% | Sanger | | |
| | Oakland | 30% | Reedley | | |
| Walnut Creek | Roseville | 50% | Dinuba | Fresno | 90% |
| | Tracy | 50% | | Bakersfield | 10% |
| E. Pleasanton | Niles | | Ivanhoe | | |
| | Tracy | 50% | Coalinga | | |
| Livermore | Niles | 50% | Huron | | |
| Elk Grove | Roseville | | Lemoor | | |
| | Roseville | 50% | Hanford | | |
| | Stockton | 30% | | | |
| | Fresno | 10% | | | |
| Ione | Tracy | 10% | | | |

Southern Pacific Company

| Interchange or Agency Station | Accounting Data Entry Point | | Interchange or Agency Station | Accounting Data Entry Point | | | |
|-------------------------------|-----------------------------|-----|-------------------------------|--------------------------------------|--------------|--|---------------------------------------|
| Goshen Jct. | Fresno | 90% | Los Angeles | Los Angeles | | | |
| Visalia | | | Compton | Los Angeles | | | |
| Exeter | | | Dolores | Los Angeles | | | |
| Lindsay | | | Bakersfield | 10% | L. A. Harbor | L. A. Harbor (Joint L. A. Harbor Belt) | |
| Porterville | | | | | Long Beach | Long Beach (Joint PE) | |
| Ducor | | | | | Downey | Los Angeles | |
| Tulare | | | | | Norwalk | Los Nietos | |
| Tipton | | | | | Anaheim | | |
| Earlimart | | | | | Santa Ana | | |
| Delano | | | Fresno | 70% | Alhambra | Los Angeles | |
| Jovista | Bakersfield | 30% | El Monte | Los Angeles | 90% | | |
| Famoso | | | Colton | Colton | 10% | | |
| Buttonwillow | Bakersfield | | City of Inudstry | Colton | 90% | | |
| Taft | | | | Bassett | Los Angeles | 10% | |
| Bakersfield | | | | Pomona | | | |
| Edison | | | | Los Nietos | Los Nietos | | |
| Tehachapi | | | | Ontario | Colton | | |
| Monolith | | | Mojave | | Colton | Colton (about 30% to move to Los Angeles) | |
| Line Pine | | | | | | | Redlands |
| Inyokern | | | | | | | Riverside |
| Mojave | | | | | | West Palm Springs | Colton |
| Lancaster | | | | | | Indio | Indio (Seasonal) -Off season -YUMA |
| Palmdale | Oxnard | | Thermal | Indio (Seasonal) -Off season-YUMA | | | |
| Oxanrd | | | | Niland | Yuma | | |
| Santa Paula | | | | Yuma | Yuma | | |
| Fillmore | Oxnard | 90% | Brawley | El Centro | | | |
| Saugus | Watsonville Jct. | 10% | Holtville | | | | |
| Santa Susana | Los Angeles | | El Centro | | | | |
| Van Nuys | Oxnard | | Calexico | | | | |
| San Fernando | Los Angeles | | | | | | |
| Glendale | Los Angeles | | | | | | |

| Interchange or Agency Station | Accounting Data Entry Point | | Interchange or Agency Station | Accounting Data Entry Point | | |
|-------------------------------|-----------------------------|------------------|-------------------------------|-----------------------------|--------|-----|
| San Francisco | San Francisco | | Herlong | Reno | | |
| South San Francisco | | | Fernley | | | |
| Millbrae | | | Reno | | | |
| San Mateo | San Jose | 50% | Mina | | | |
| Redwood City | Oakland | 25% | Luning | | | |
| Palo Alto | Tracy | 25% | Thorne | | | |
| Sunnyvale | San Jose | 90% | Wabuska | | | |
| San Jose | | Tracy | 10% | | Fallon | |
| Gilroy | San Jose | | Lovelock | | Reno | 80% |
| Hollister | | | Ogden | | Ogden | 20% |
| Santa Cruz | | | Ogden | | Ogden | |
| Watsonville Jct. | Watsonville Junction | | Imlay | | | |
| Castroville | | | Winnemucca | | | |
| Monterey | | | Battle Mountain | | | |
| Salinas | Watsonville Junction | | Beowawe | Reno | 50% | |
| Gonzales | | | Carlin | Ogden | 50% | |
| Soledad | | | Elko | | | |
| King City | Watsonville Jct. | 90% | Wells | | | |
| Paso Robles | Los Angeles | 10% | Cobre | | | |
| San Luis Obispo | | | Montello | | | |
| Oceano | Guadalupe | | Wellton | | | |
| Guadalupe | | | Buckeye | | | |
| Lompoc | | | Litchfield | | | |
| Gaviota | Los Angeles | 90% | Phoenix | Phoenix | | |
| Goleta | | Watsonville Jct. | 10% | | Tovrea | |
| Santa Barbara | Los Angeles | 80% | Tempe | | | |
| Westwood | | Watsonville Jct. | 20% | | Mesa | |
| Susanville | Reno | | Gilbert | | | |
| Wendel | | | Ray Jct. | | | |
| | | | Hayden | | | |
| | | | Elroy | | Yuma | 50% |
| | | | | | Tucson | 50% |

| Interchange or Agency Station | Accounting Data Entry Point | | Interchange or Agency Station | Accounting Data Entry Point | |
|-------------------------------|-----------------------------|-----|-------------------------------|-----------------------------|-----|
| Gila | Tucson | | Vaughn | El Paso | |
| Casa Grande | | | Sanata Rosa | | |
| Chandler | | | El Paso | | |
| Coolidge | | | Tucumcari | | |
| Tucson | | | Roy | | |
| Sahaurita | | | | | |
| Nogales | | | | | |
| Benson | | | | | |
| Fairbanks | | | Tucson | | 50% |
| Hereford | | | El Paso | | 50% |
| Naco | Douglas | | | | |
| Bisbee | | | | | |
| Douglas | | | | | |
| Curtiss | Tucson | | | | |
| Animas | El Paso | | | | |
| Hachita | | | | | |
| Columbua | | | | | |
| Clifton | | | | | |
| Duncan | | | | | |
| Deming | | | | | |
| Safford | | | Tucson | | |
| Willcox | | | | | |
| Bowie | | | El Paso | | |
| Lordsburg | | | | | |
| Miami | El Paso | 90% | | | |
| Orogrande | Tucson | 10% | | | |
| Alamagordo | | | | | |
| Tularosa | | | | | |
| Carrizozo | Tucumcari | 60% | | | |
| Corona | El Paso | 40% | | | |

PACIFIC ELECTRIC RAILWAY COMPANY

| Interchange or Agency Station | Accounting Data Entry Point | Interchange or Agency Station | Accounting Data Entry Point | |
|-------------------------------|-----------------------------------|-------------------------------|-----------------------------|-----------------|
| San Fernando | Los Angeles | Garden Grove | Los Nietos | |
| Hollywood | | Santa Ana | | |
| Culver City | | Orange | | |
| Santa Monica | | Los Angeles Harbor | Los Nietos | Los Nietos |
| El Monte | | | Whittier | Los Nietos 80% |
| Los Angeles | | | La Habra | Los Angeles 20% |
| Los Angeles Harbor | Long Beach | Yorba Linda | Los Angeles 90% | |
| Long Beach | | Azusa | Colton 5% | |
| Watson | Los Nietos 60% Los Angeles 40% | Upland | Los Nietos 5% | |
| Torrance | | San Bernardino | Colton | |
| Gardena | | Corona | | |
| Compton | | Colton | | |
| Hawthorne | | | | |
| El Segundo | | | | |
| Bellflower | | | | |
| Huntington Beach | | | Wingfoot | Los Nietos 20% |
| | | | | Los Angeles 80% |

NORTHWESTERN PACIFIC RAILROAD COMPANY

| Interchange or Agency Station | Accounting Data Entry Point | Interchange or Agency Station | Accounting Data Entry Point |
|-------------------------------|-----------------------------------|-------------------------------|-----------------------------------|
| Arcata | Eureka | Ukiah | Santa Rosa 50% Schellville 50% |
| Eureka | | Cloverdale | |
| Fortuna | | Healdsburg | |
| Scotia | | Santa Rosa | |
| South Fork | | Sebastopol | |
| Fort Seward | Santa Rosa 50% Schellville 50% | Petaluma | |
| Alderpoint | | San Rafael | |
| Dos Rios | | Tiburon | |
| Willits | | Sausalito | |

Southern Pacific Company

SAN DIEGO AND ARIZONA EASTERN RAILWAY COMPANY

Interchange or
Agency Station

Accounting Data
Entry Point

San Diego
San Ysidro
Campo
Plaster City

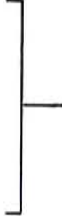





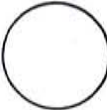
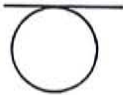
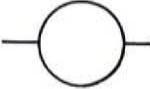

El Centro

OPERATING FLOW DIAGRAMS

These diagrams show the representative movements of trains and switch engines in each division of the Southern Pacific System.

EXPLANATION OF SYMBOLS

-  Industrial zones, spurs, team tracks. Origination or termination of carload traffic.
-  Point at which responsibility for cars is transferred from one operating employee to another, i. e., yardmaster to or from conductor or engine foreman; conductor to or from conductor.
-  Pick up or set out point. Symbol of train is not changed in performing this operation.
-  Pick up or set out point, classification point; symbol of train or block of cars is significantly changed after passing through this operation.
-  Interchange
-  Crew on and off duty point.
-  Crew turn around point or practical operating limit.
-  Line of operation for local, manifest or drag.
-  Hyphenated circle, square, or line, indicates seasonal or temporary operation.

PORTLAND DIVISION PART-I

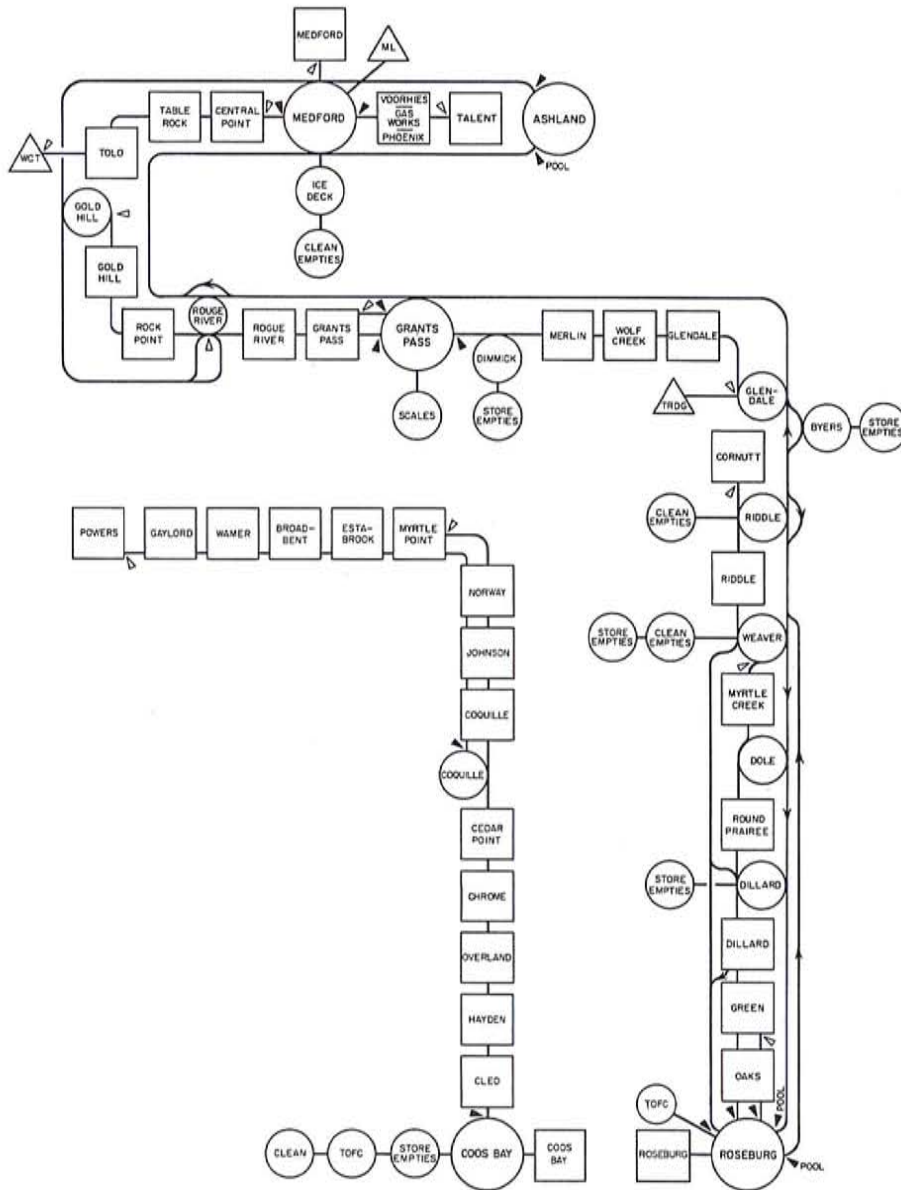

PORTLAND DIVISION PART-2

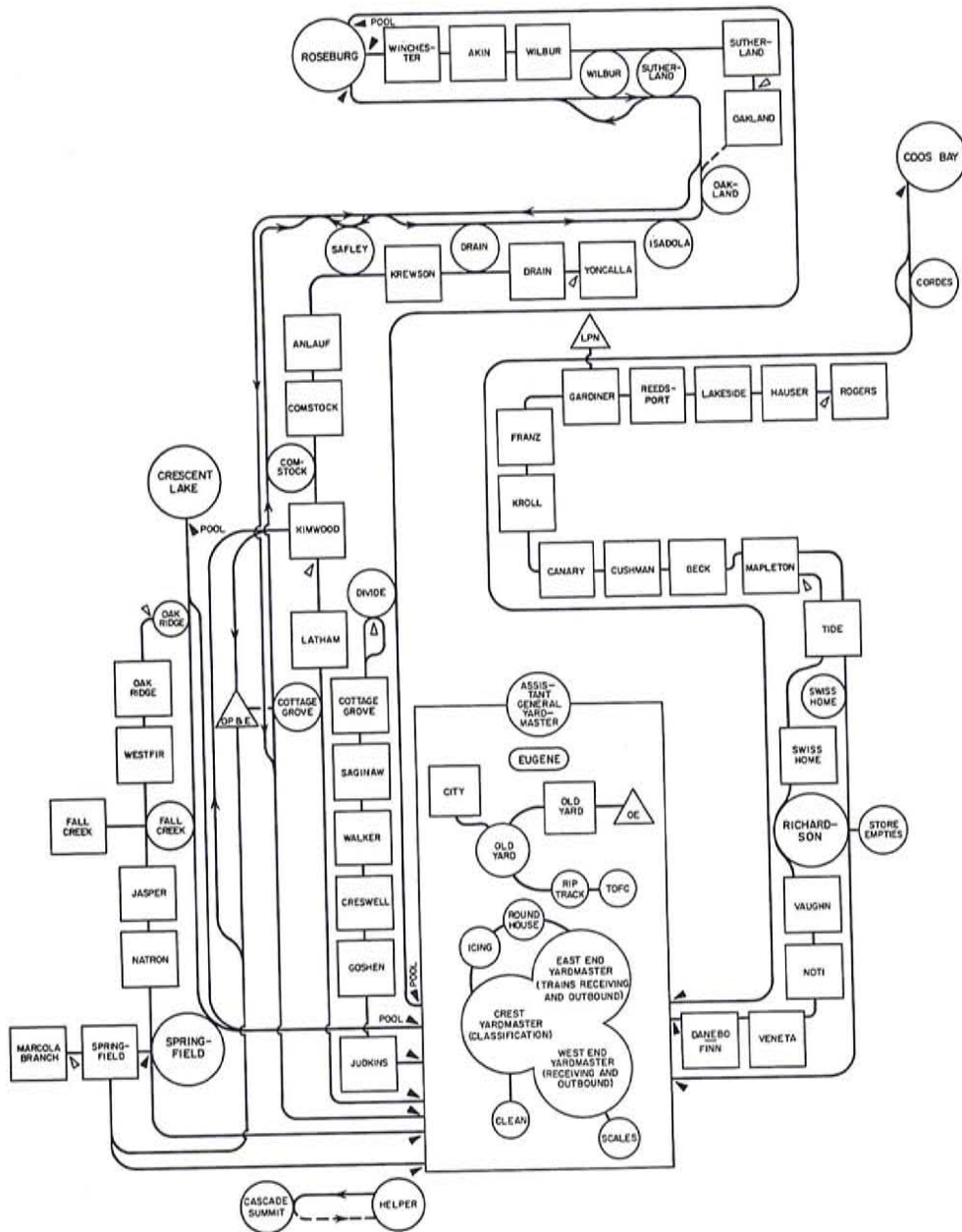

PORTLAND DIVISION - PART 3
EAST SIDE

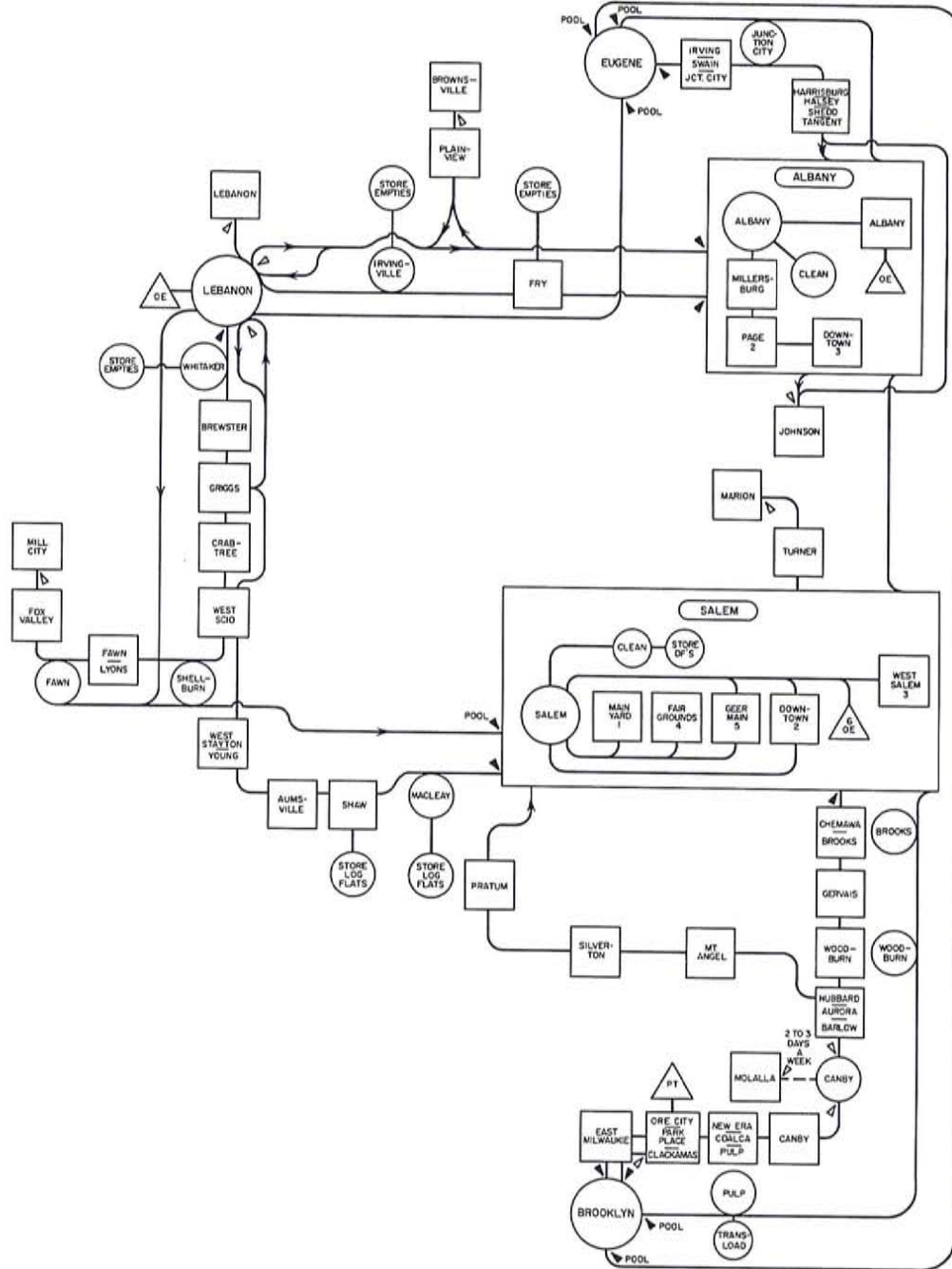

SALT LAKE DIVISION

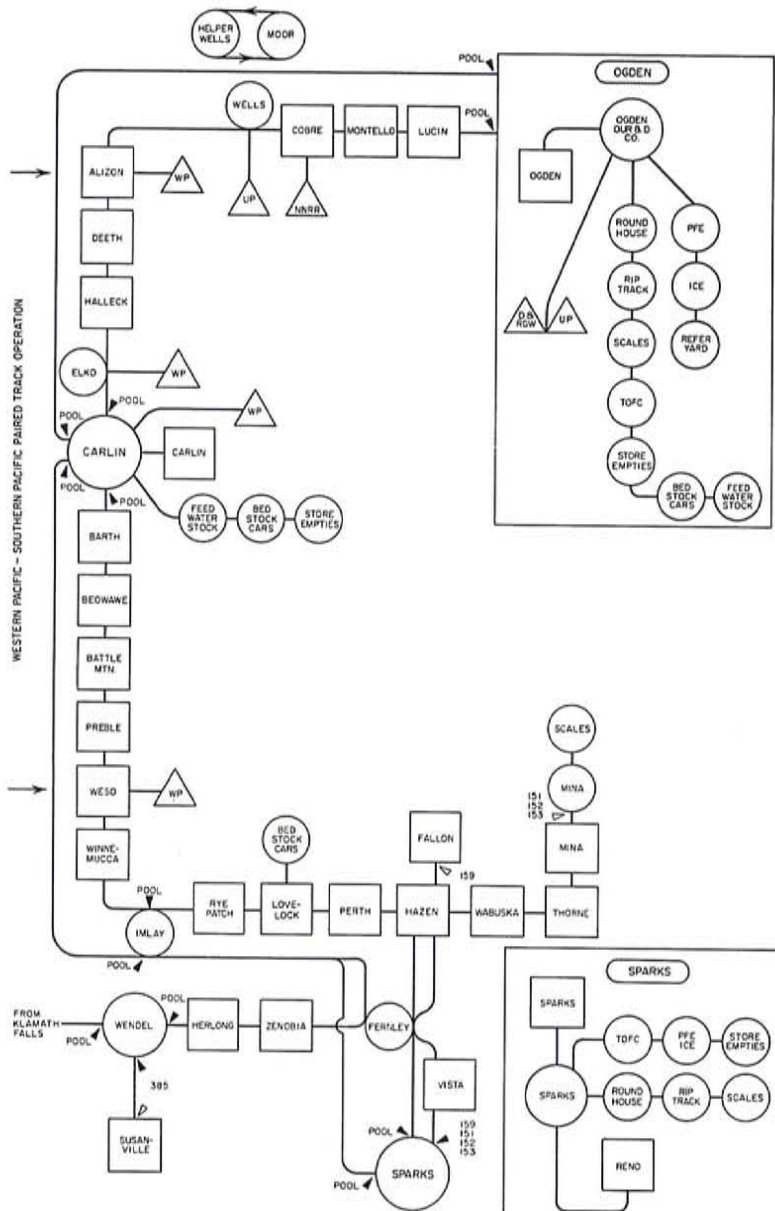

SACRAMENTO DIVISION - PART I

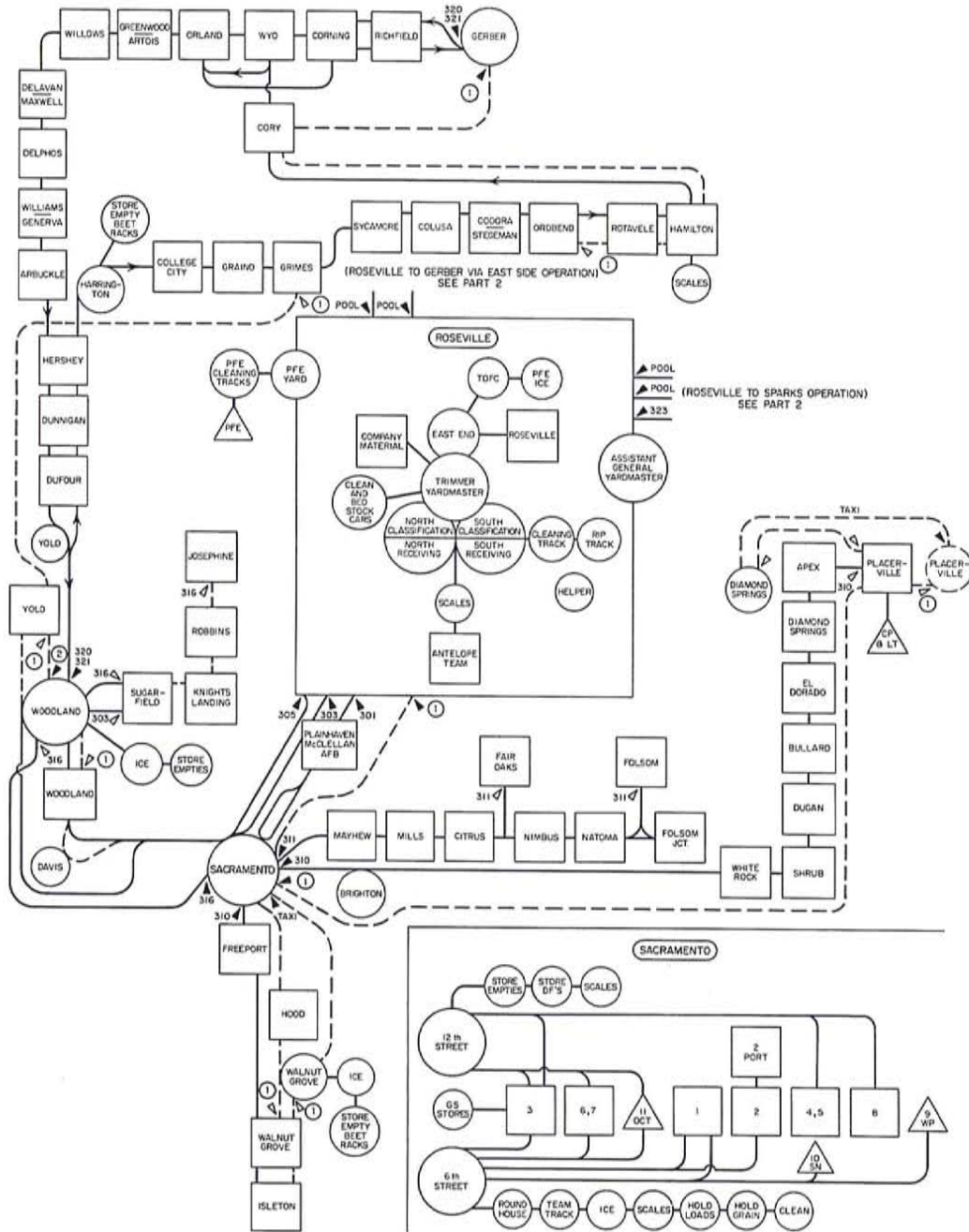

SACRAMENTO DIVISION PART 2

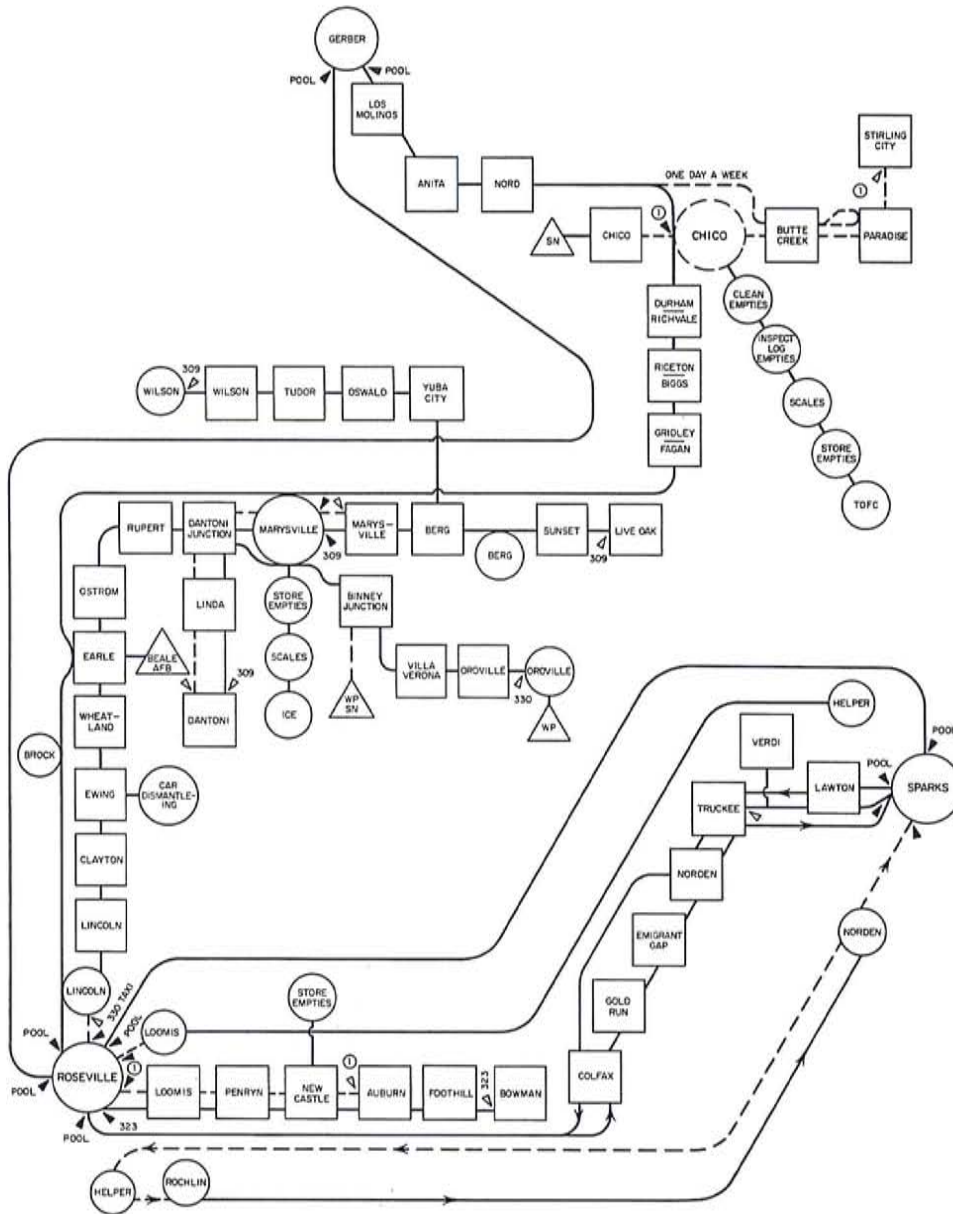

WESTERN DIVISION PART 3

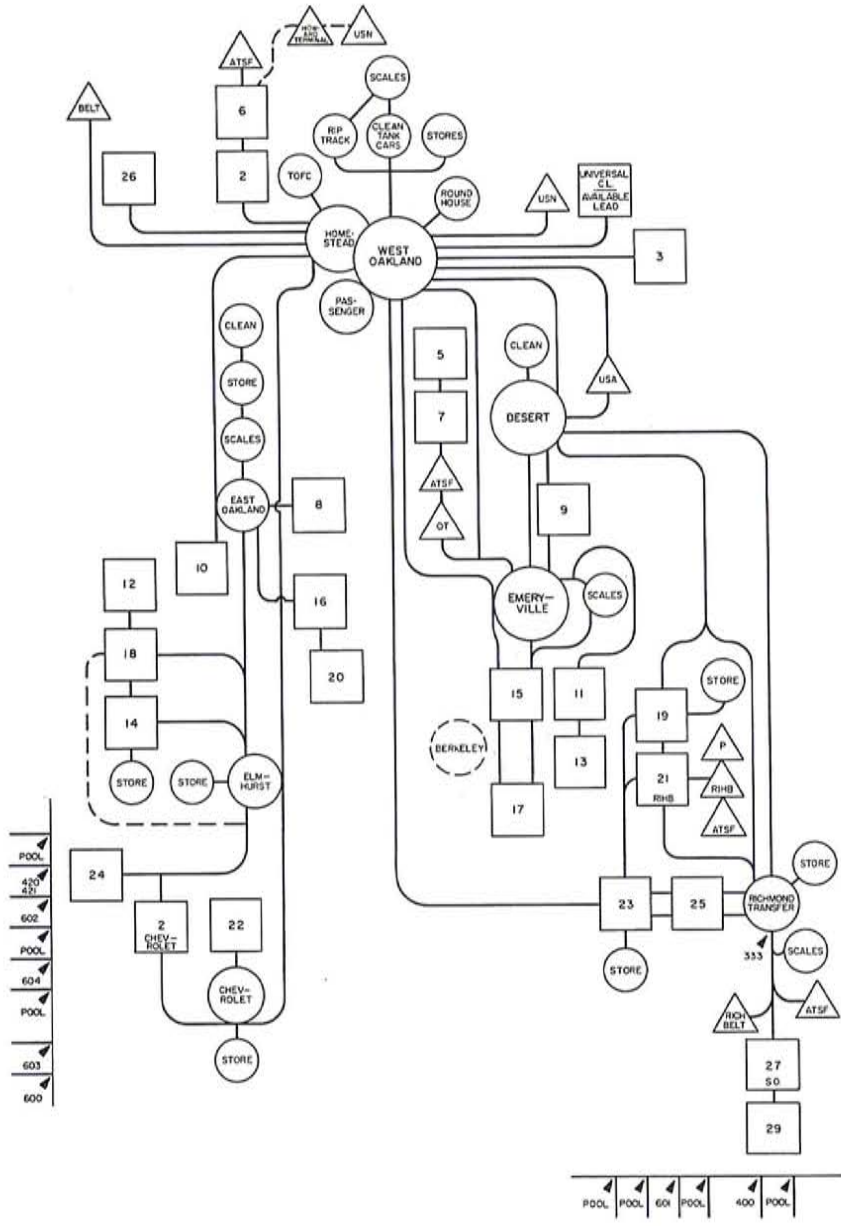

COAST DIVISION PART-I

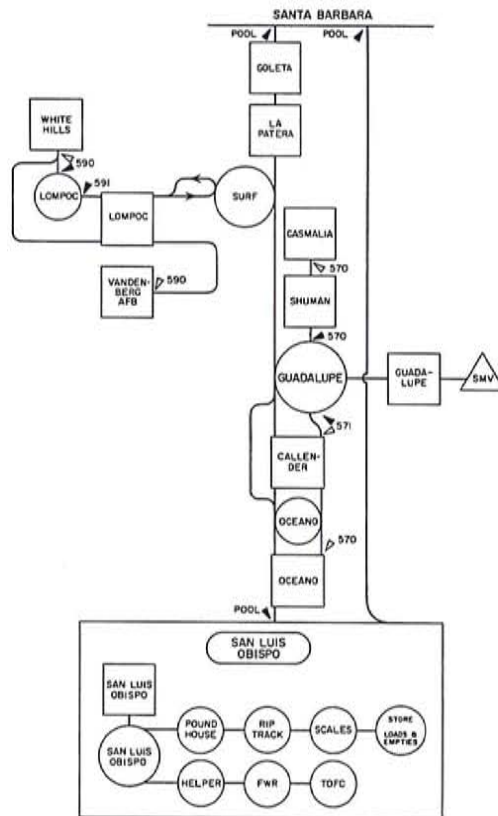

COAST DIVISION - PART 3

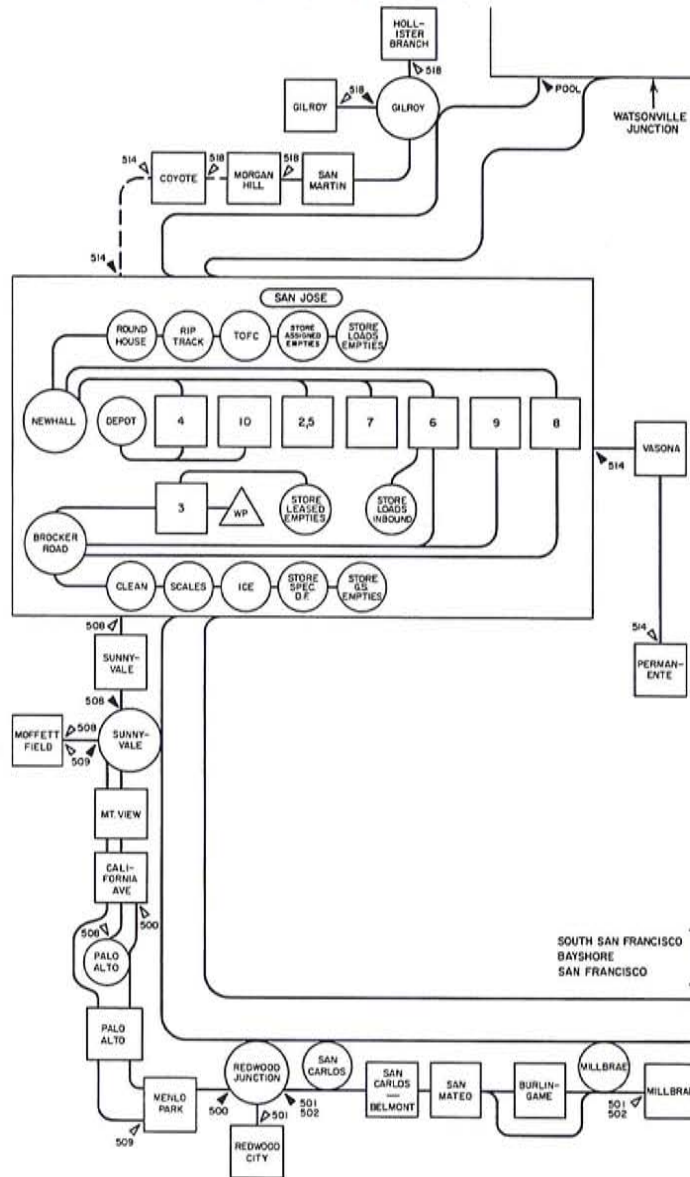

COAST DIVISION PART 4

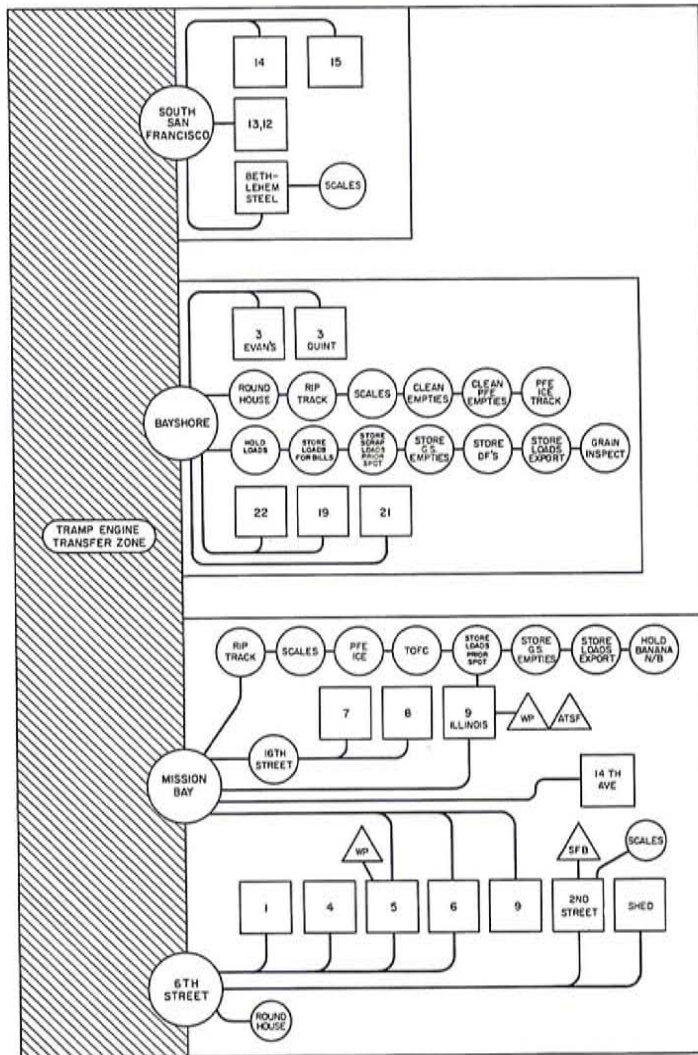

SAN JOAQUIN PART - I

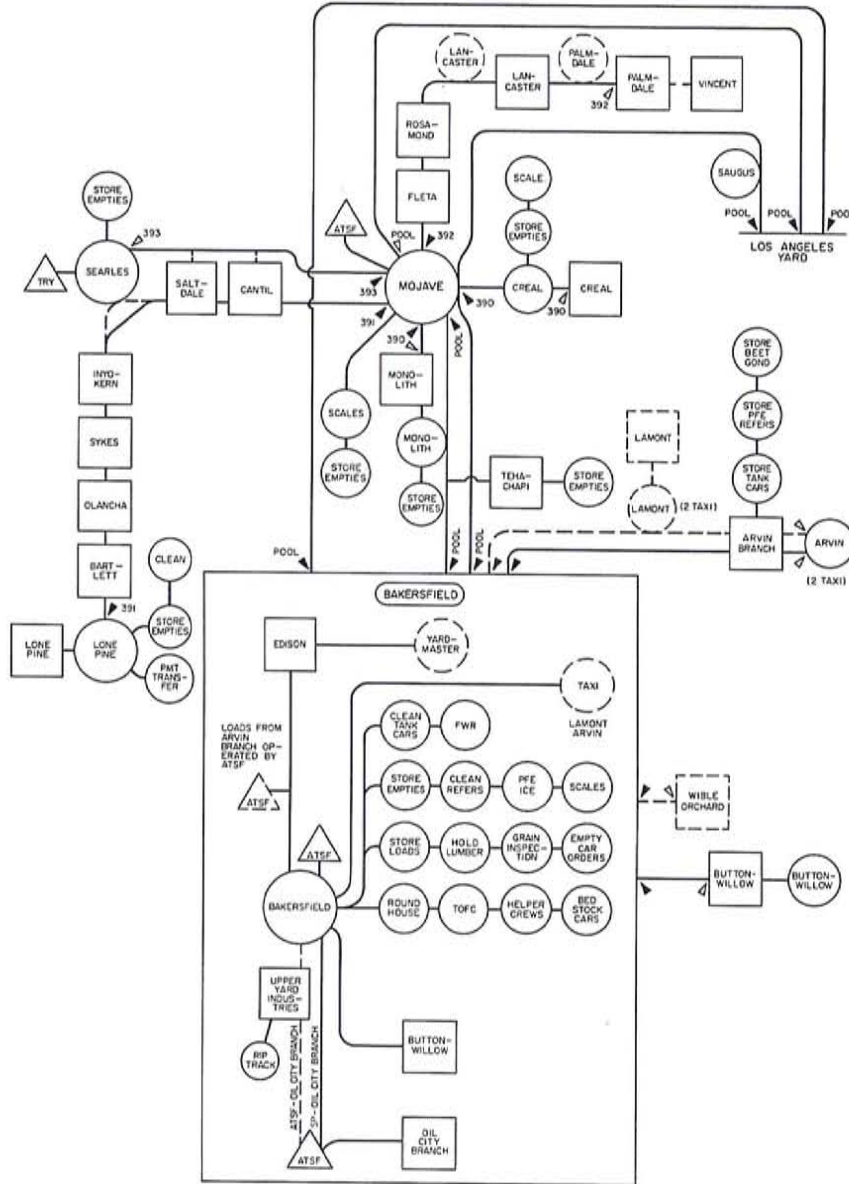

SAN JOAQUIN DIVISION PART 2

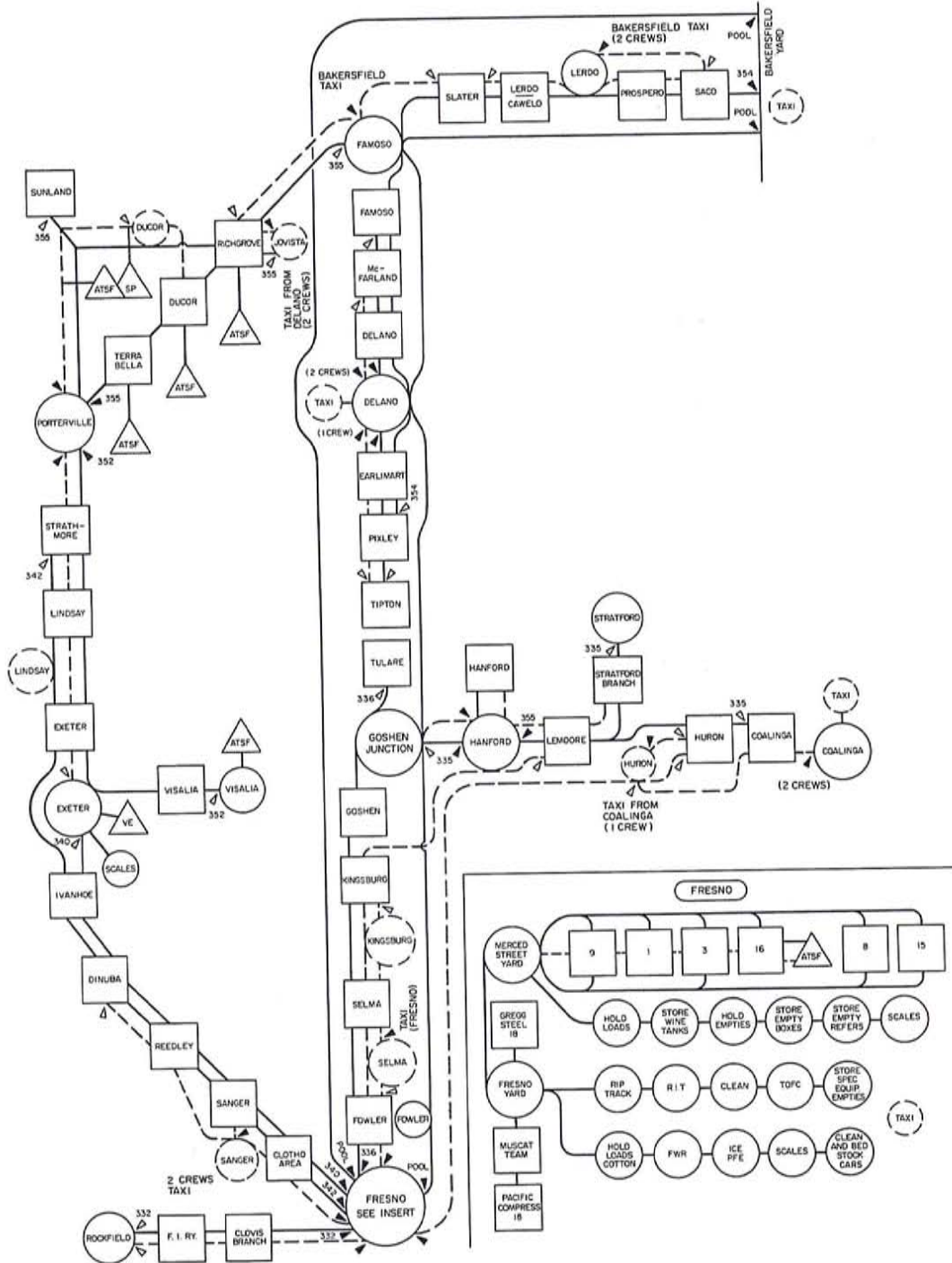

LOS ANGELES DIVISION PART I

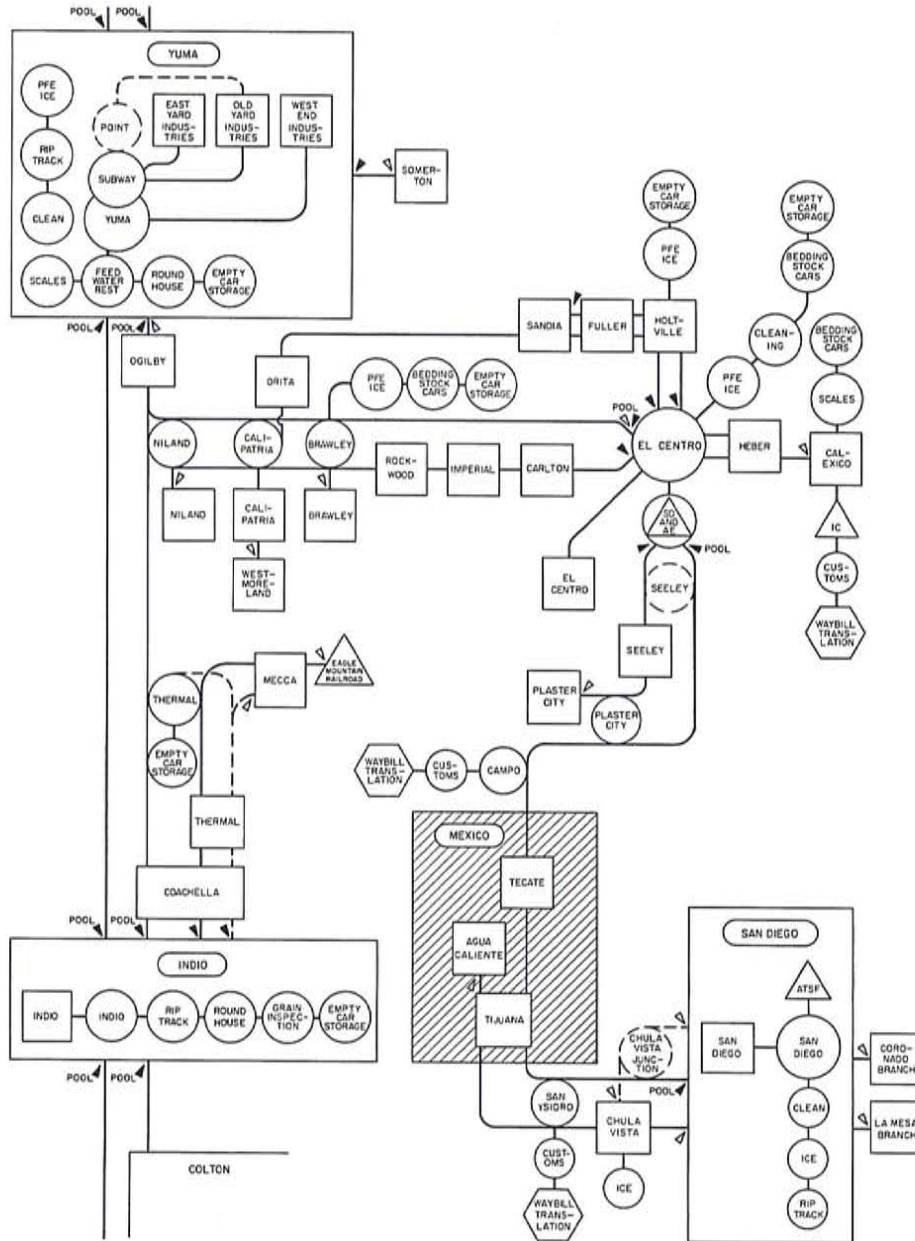

LOS ANGELES DIVISION PART 2

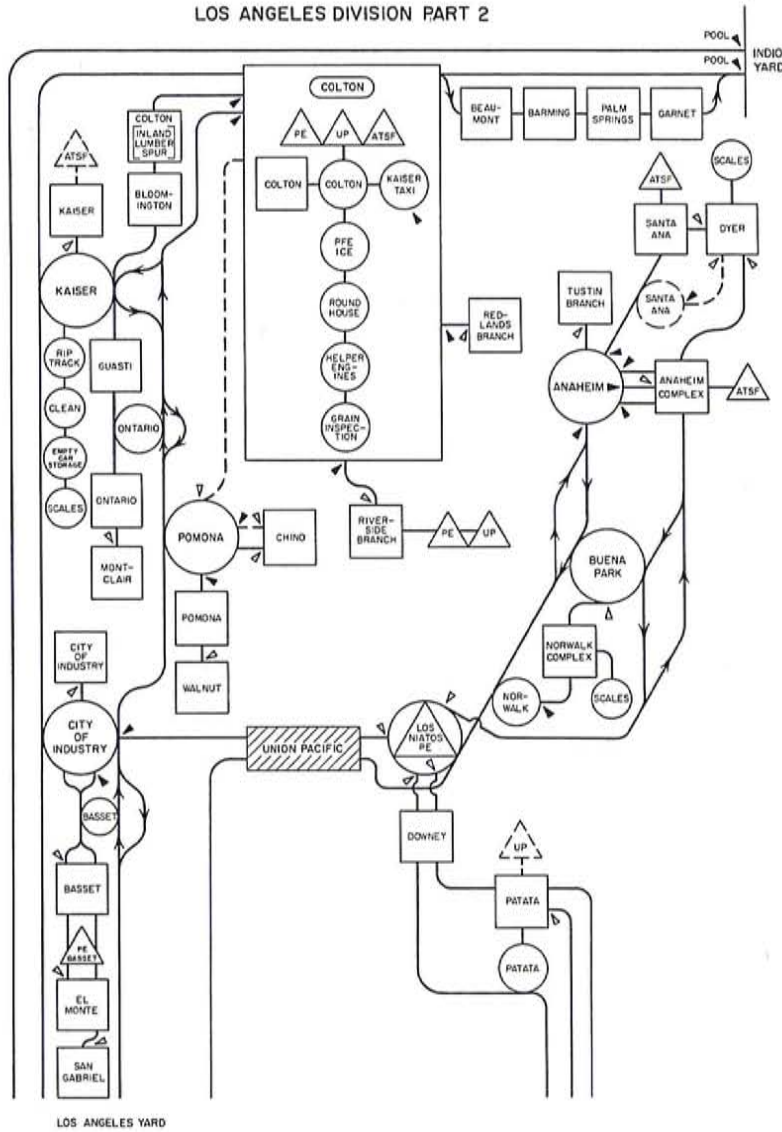

LOS ANGELES - PART 4

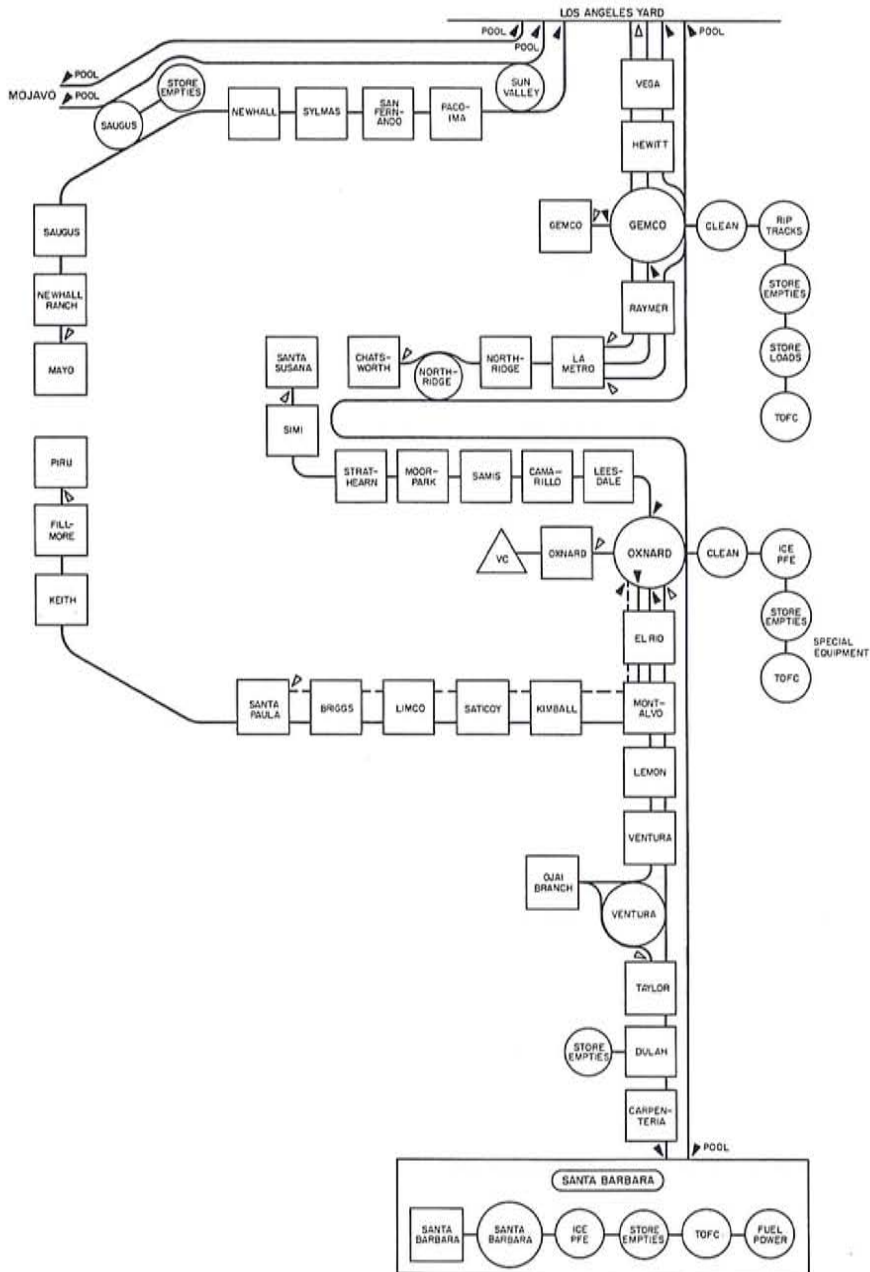

TUCSON DIVISION

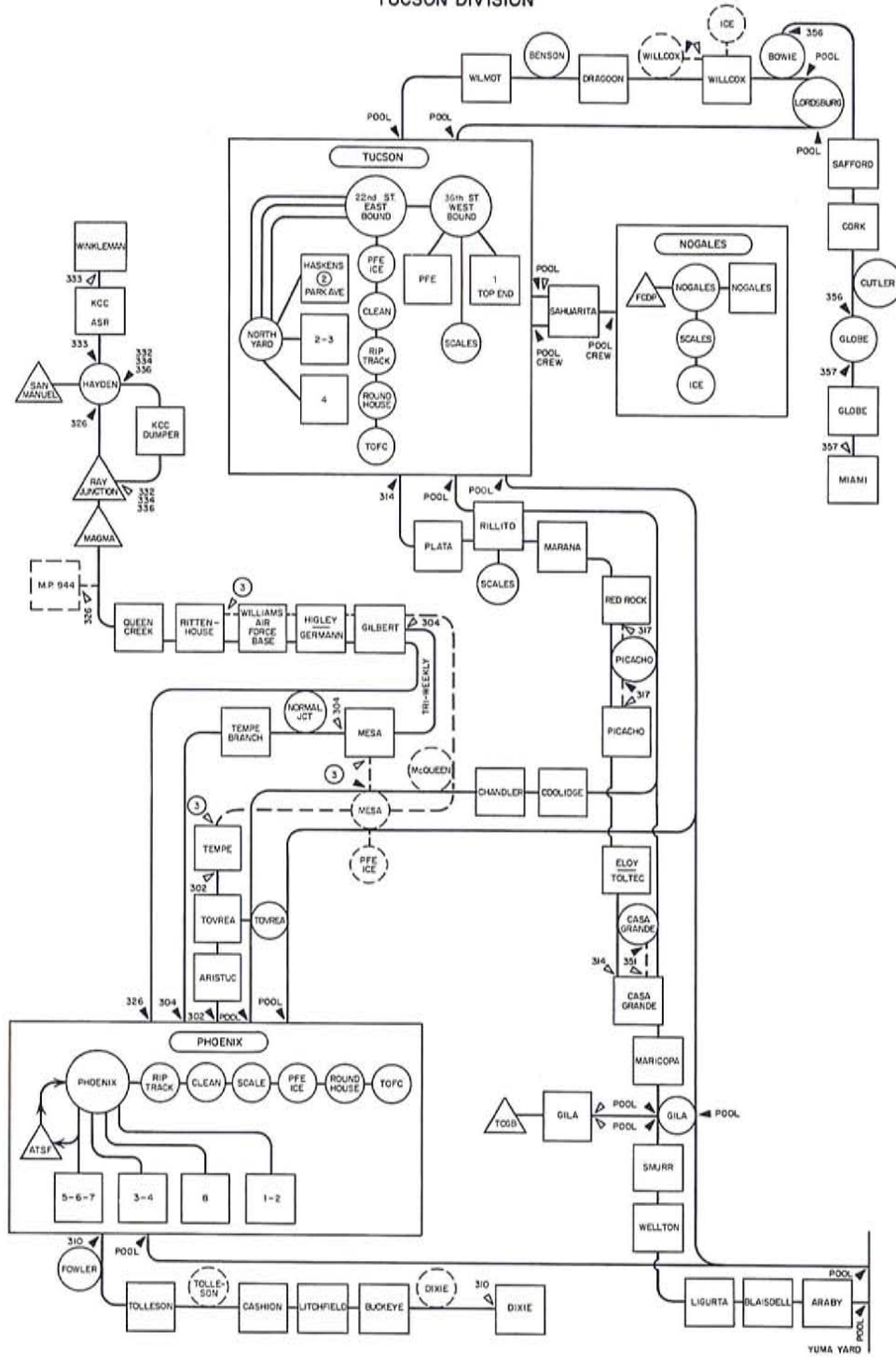

RIO GRANDE DIVISION

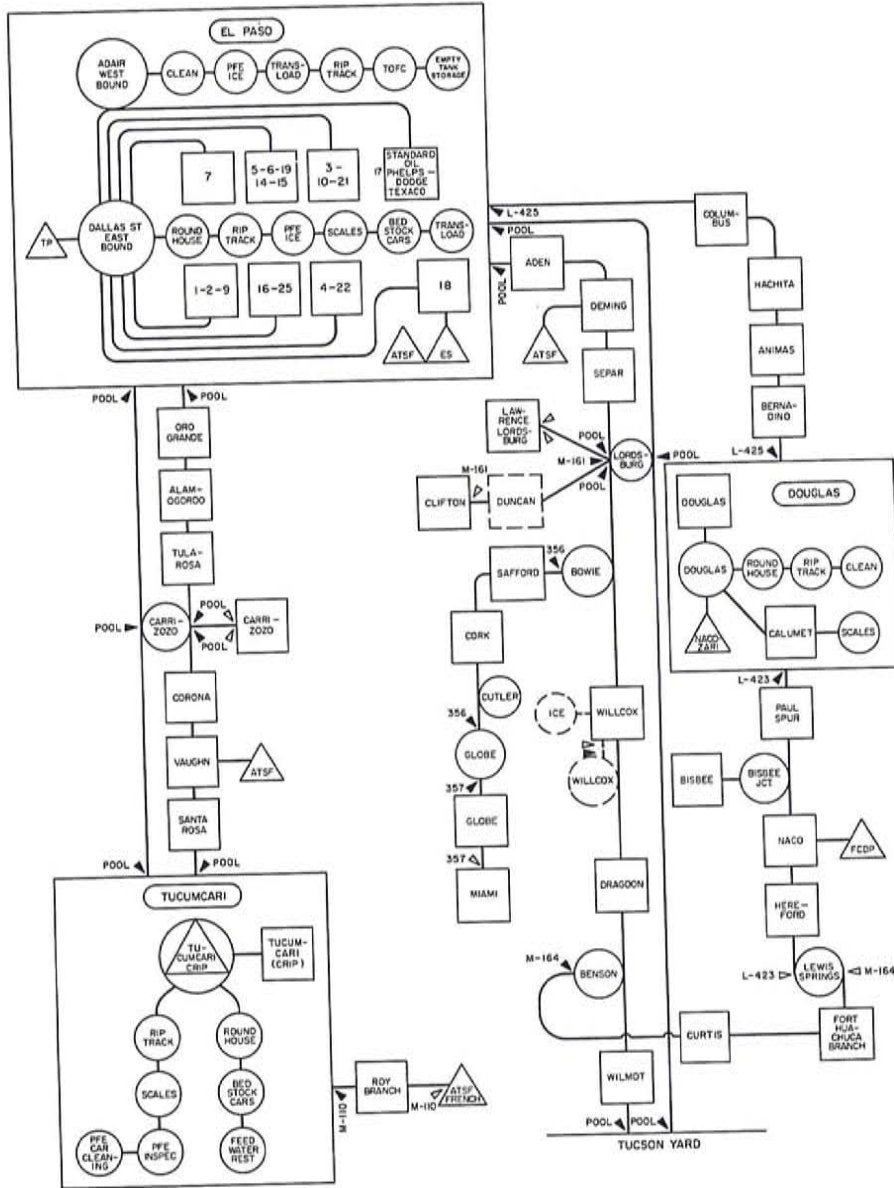

DALLAS - AUSTIN DIVISION

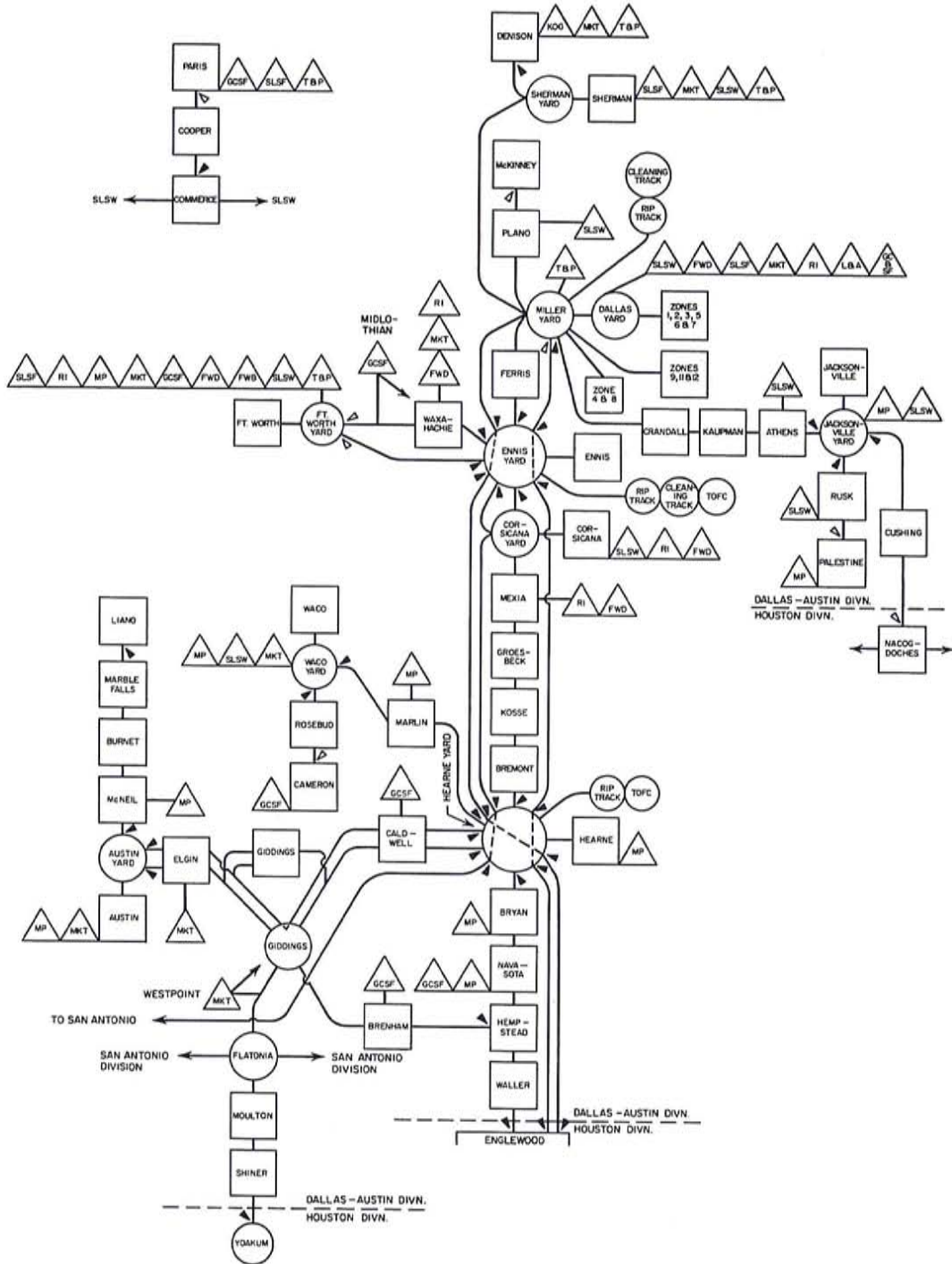

LAFAYETTE DIVISION

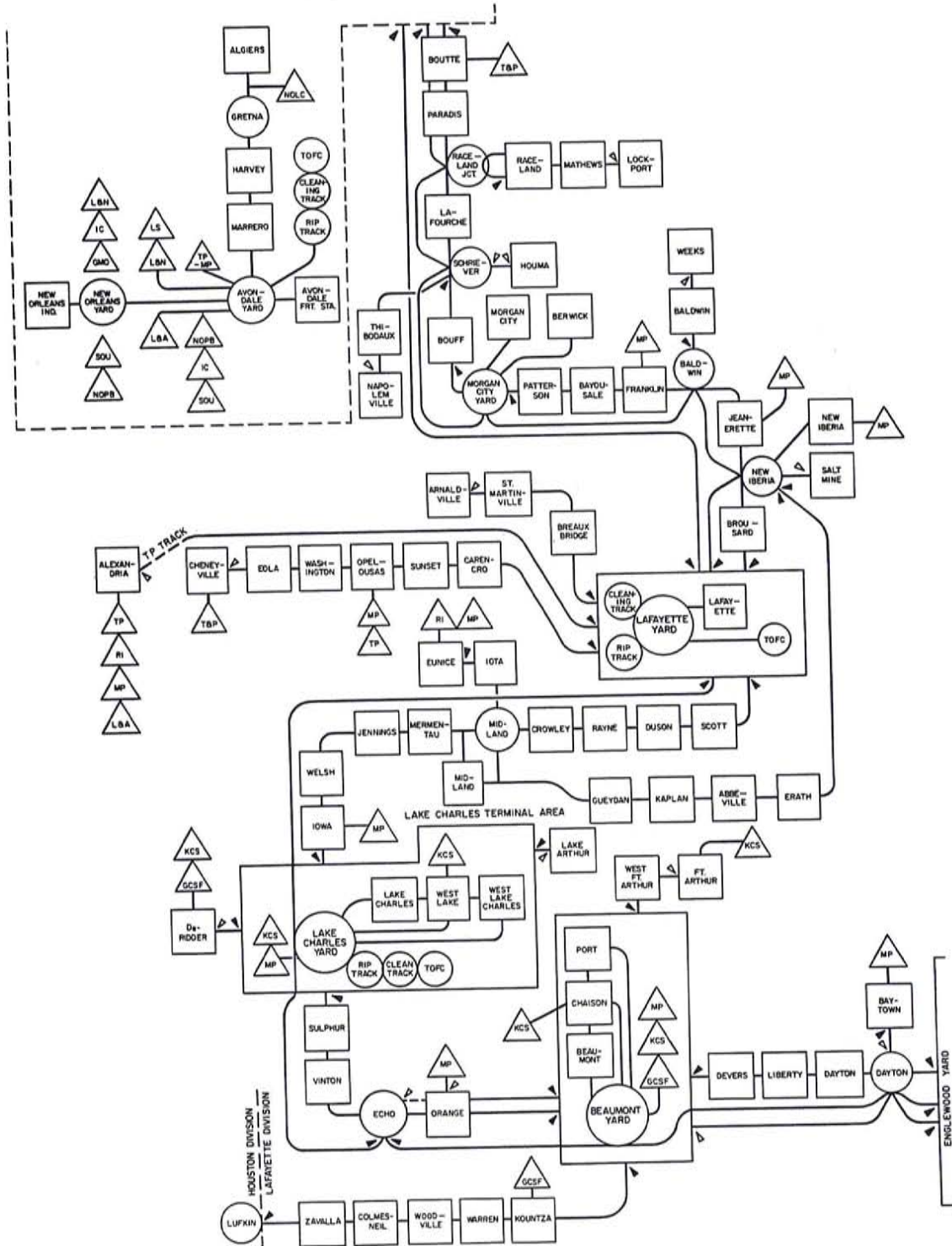

PACIFIC ELECTRIC RAILWAY

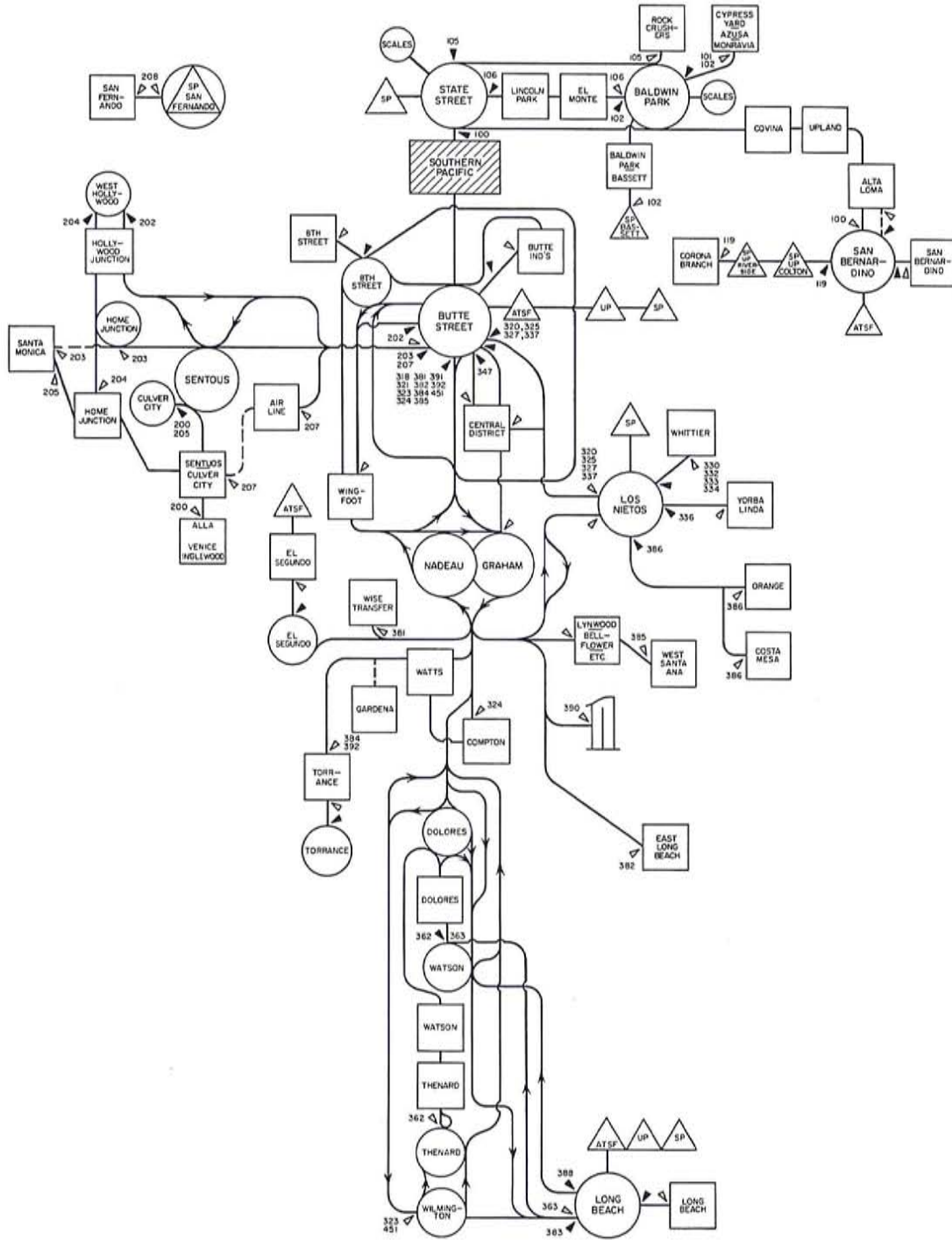

NORTHWESTERN PACIFIC RR
(NORTH)

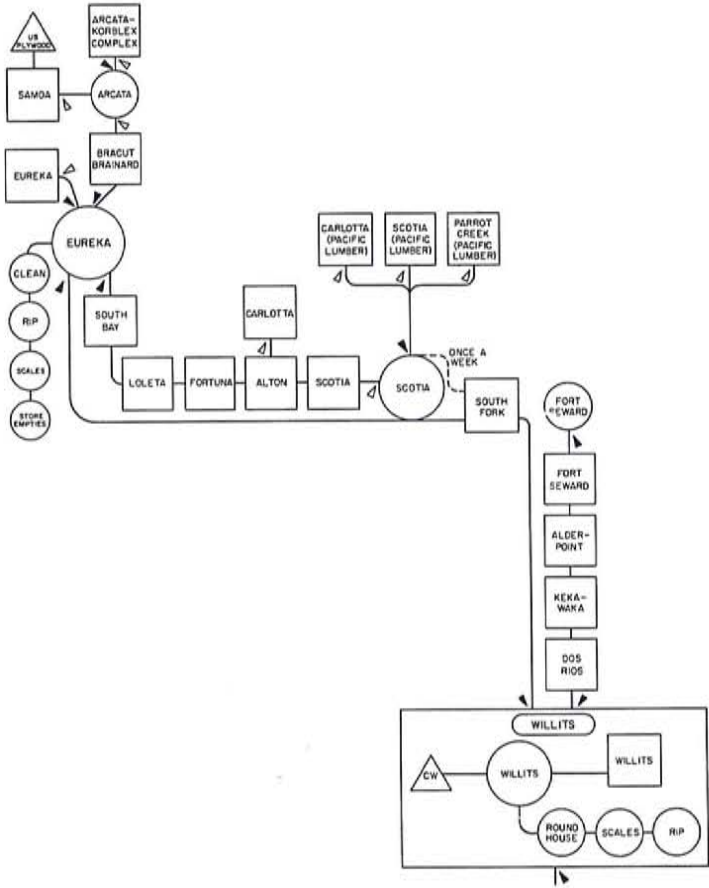

**NORTHWESTERN PACIFIC RR.
(SOUTH)**

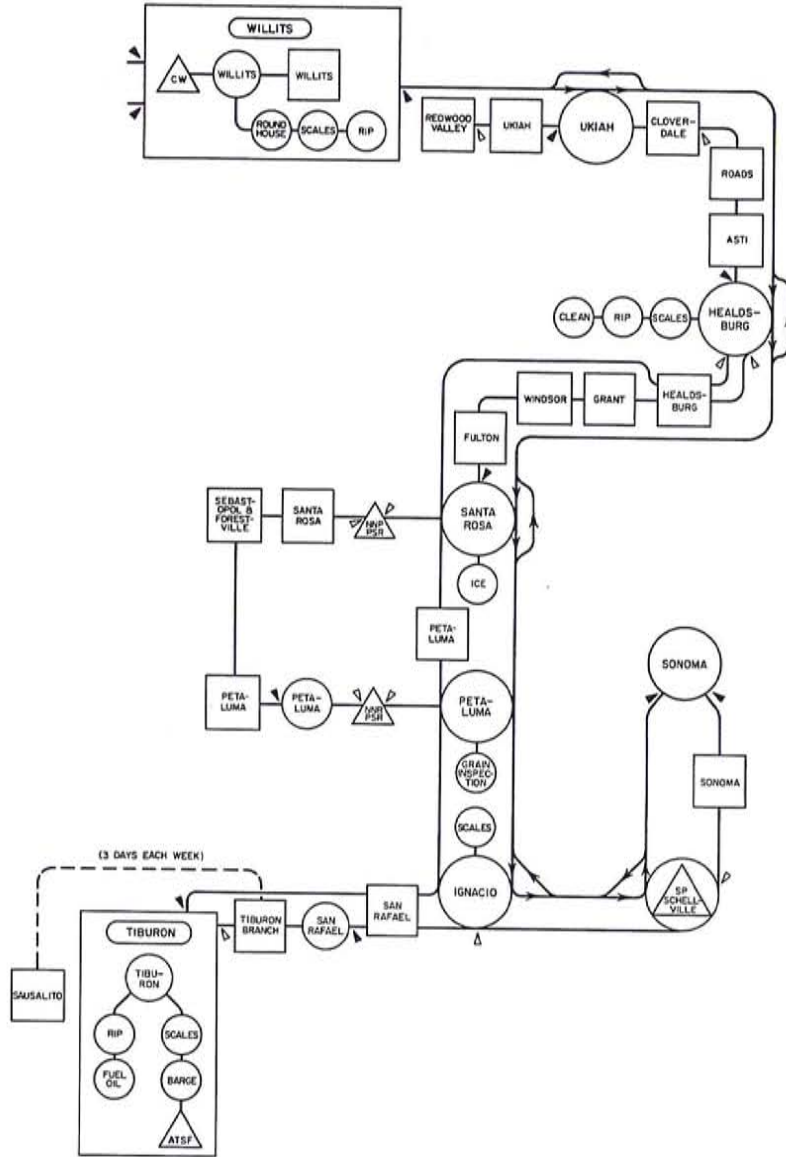

TRI-HOURLY TRAIN STATISTICS

The two graphs and the listings in this section outline train operations on the Pacific Lines (for October, 1960) and the Texas and Louisiana Lines (for October, 1960). The graphs give an over-all picture of operations in the Southern Pacific System and the listings illustrate operation of individual stations.

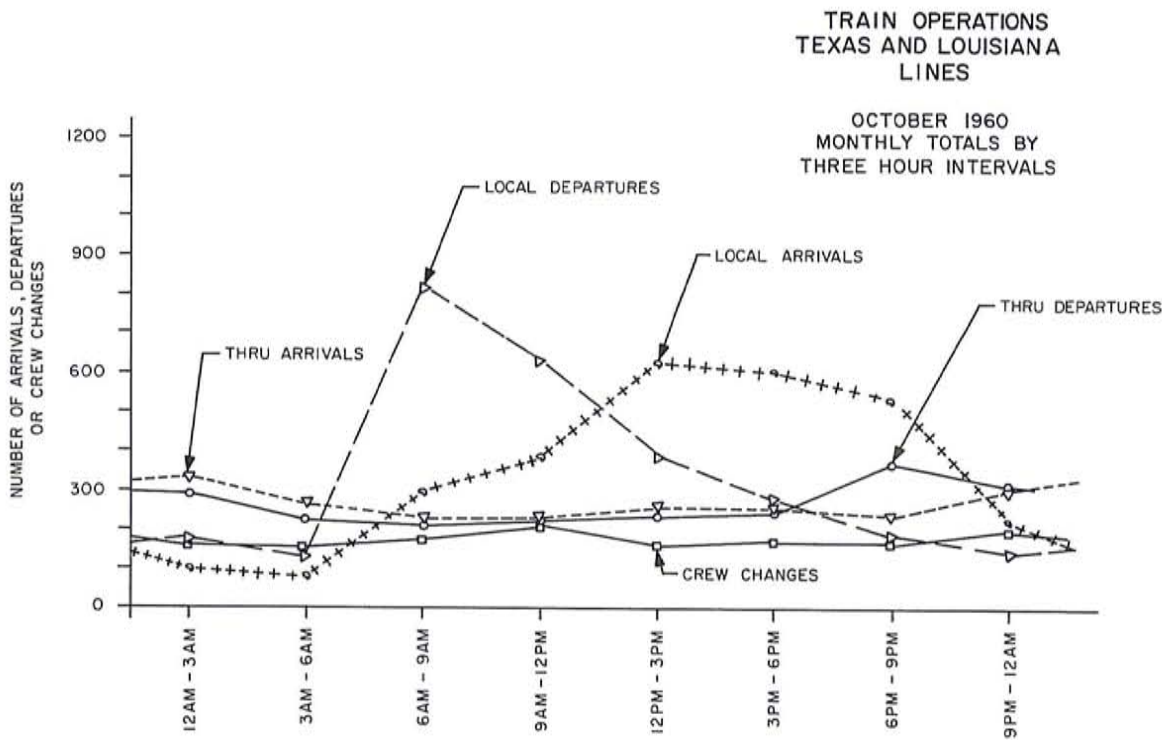
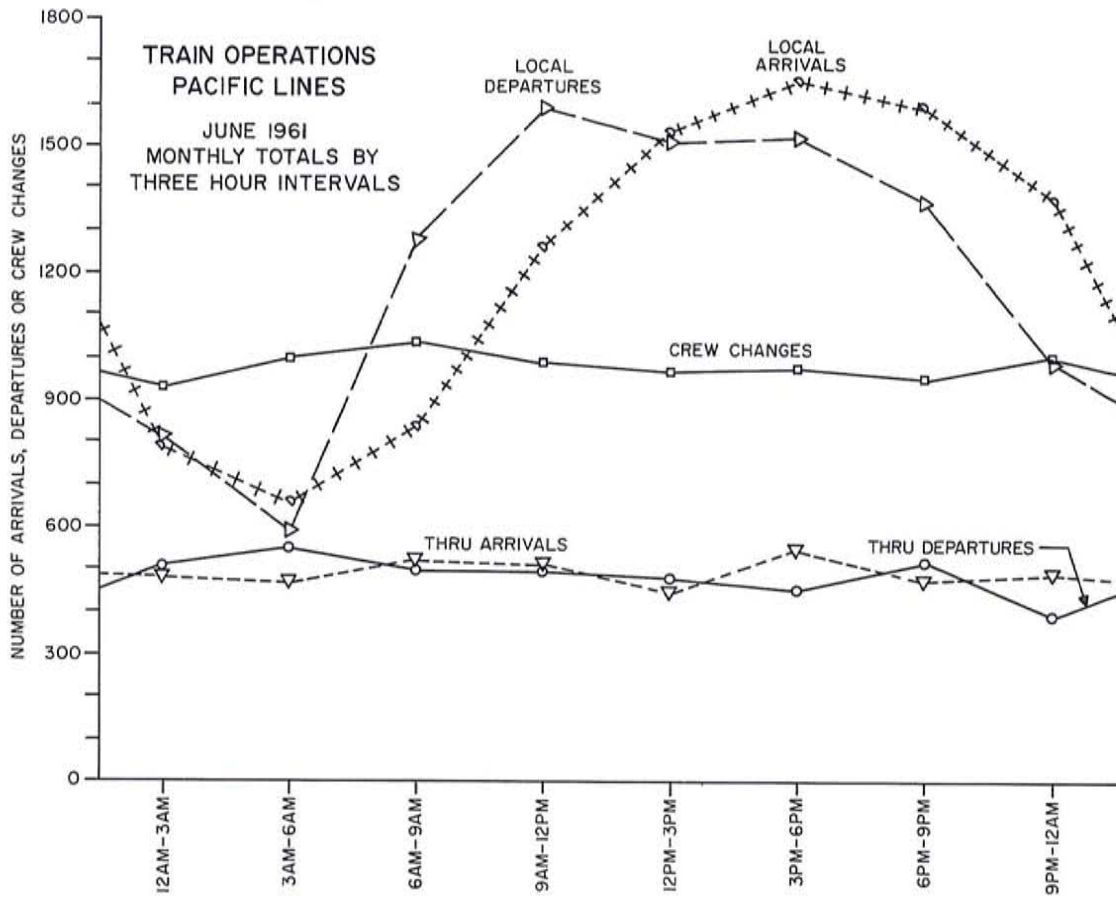

TRAIN STATISTICS - PACIFIC LINES (OCTOBER 1960)

| Station | Sta. No. | Thru Departures | Local Departures | Thru Arrivals | Local Arrivals | Crew Changes | Total |
|------------------|-------------|--------------------|---------------------|------------------|-------------------|-----------------|-------|
| Mission Bay | 1 | 10 | 5 | 13 | 81 | | |
| Bayshore | 5 | 3 | 192 | | 176 | | 371 |
| Redwood Jct. | 26 | 2 | 38 | | 32 | | 72 |
| Millbrae | 14 | | 37 | | 47 | | 84 |
| San Carlos | 23 | 21 | 6 | | 23 | | 50 |
| Menlo Park | 29 | | 11 | | 11 | | 22 |
| Totals | | 23 | 92 | | 113 | | 228 |
| Sunnyvale | 39 | 2 | 50 | 24 | 48 | | 124 |
| Palo Alto | 30 | | 35 | | 18 | 23 | 76 |
| California Ave. | 32 | | 6 | 1 | 4 | 1 | 12 |
| Totals | | 2 | 91 | 25 | 70 | 24 | 212 |
| San Jose | 47 | 1 | 8 | 5 | 10 | 1 | 25 |
| Santa Clara | 44 | 65 | 435 | 41 | 462 | 5 | 1008 |
| San Jose Yard | 45 | | 24 | 3 | 26 | | 53 |
| Permanent | 510 | | 10 | | 10 | 1 | 21 |
| Totals | | 66 | 477 | 49 | 508 | 7 | 1107 |
| Gilroy | 77 | 15 | 13 | 6 | 13 | 4 | 51 |
| Coyote | 59 | | 4 | | 5 | 4 | 13 |
| Morgan Hill | 67 | | 1 | 1 | 1 | 11 | 14 |
| San Martin | 71 | | 1 | | 1 | 7 | 9 |
| Hollister | 812 | 10 | 13 | 15 | 9 | | 47 |
| Totals | | 25 | 32 | 22 | 29 | 26 | 134 |
| Watsonville Jct. | 97 | 79 | 318 | 79 | 328 | 65 | 869 |
| Corporal | 82 | | 12 | | 11 | | 23 |
| Sargent | 83 | | 3 | | 4 | | 7 |
| Logan | 89 | | 4 | | 4 | | 8 |
| Moss Landing | 104 | | 3 | | 5 | | 8 |
| Castroville | 107 | | 3 | | 14 | | 17 |
| Soledad | 140 | | 15 | | | | 15 |
| Prateco | 1012 | 1 | 14 | 1 | 12 | | 28 |
| Monterey | 1116 | | 20 | | 19 | | 39 |
| Lake Magella | 1120 | | 12 | | 13 | | 25 |
| Totals | | 80 | 404 | 80 | 410 | 65 | 1039 |
| San Luis Obispo | 248 | 8 | 83 | 31 | 39 | 212 | 373 |
| Grover | 260 | 1 | 1 | 1 | 1 | 2 | 6 |
| Totals | | 9 | 84 | 32 | 40 | 214 | 379 |
| Salinas | 114 | | 76 | | 78 | | 154 |

Southern Pacific Company

| Station | Sta. No. | Thru Departures | Local Departures | Thru Arrivals | Local Arrivals | Crew Changes | Totals |
|---------------|----------|-----------------|------------------|---------------|----------------|--------------|--------|
| Guadalupe | 273 | 5 | 18 | 5 | 18 | 1 | 47 |
| Santa Barbara | 367 | 21 | 95 | 34 | 109 | 193 | 452 |
| Santa Cruz | 920 | | 19 | | 19 | 2 | 40 |
| Felton | 929 | | 14 | | 15 | | 29 |
| Totals | | | 33 | | 34 | 2 | 69 |
| Lompoc | 1310 | | 39 | | 38 | | 77 |
| Surf | 299 | | 18 | | 19 | | 37 |
| Totals | | | 57 | | 57 | | 114 |
| Fresno | 1400 | 11 | 539 | 8 | 563 | 245 | 1366 |
| Goshen Jct. | 1437 | 1 | | | 1 | 15 | 17 |
| Tulare | 1448 | | 11 | | 11 | | 22 |
| Delano | 1479 | 27 | | | | | 27 |
| Locans | 1711 | | | | | 1 | 1 |
| Sanger | 1718 | | 23 | 1 | 22 | 1 | 47 |
| Reedley | 1728 | | | | | 1 | 1 |
| Dinuba | 1733 | | 13 | | 14 | | 27 |
| Exeter | 1756 | | 1 | | 1 | | 2 |
| Fresno Tower | 1802 | | | 1 | | | 1 |
| Las Palmas | 1808 | 2 | 34 | 1 | 34 | | 71 |
| Pinedale | 1815 | 1 | 15 | 1 | 15 | | 32 |
| Rockfield | 1820 | | 8 | 1 | 7 | | 16 |
| Hammond | 1900 | | 1 | | 1 | 2 | 4 |
| Bartonette | 1903 | | 1 | | 1 | 2 | 4 |
| Cameo | 1906 | | 1 | | 1 | 2 | 4 |
| Burness | 1908 | | 1 | 1 | | | 2 |
| Zediker | 1915 | 1 | 1 | | 2 | 1 | 5 |
| Gustine | 9189 | | 23 | | 24 | 1 | 48 |
| Ingle | 9247 | | | | 1 | 5 | 6 |
| Berenda | 9484 | | 1 | | 1 | | 2 |
| Biola | 9308 | | | | | 1 | 1 |
| Madera | 9491 | 1 | | 1 | | | 2 |
| Burrell | 9974 | | 1 | | | | 1 |
| Totals | | 44 | 674 | 15 | 699 | 277 | 1709 |
| Delano | 1479 | | 31 | | 34 | 13 | 78 |
| Tipton | 1459 | | 1 | | | | 1 |
| Pixley | 1465 | | 1 | | | 1 | 2 |
| Earliment | 1471 | | 5 | 4 | 6 | 27 | 42 |
| Radnor | 1475 | | 1 | | | 6 | 7 |
| Vinland | 1483 | | 3 | 1 | 3 | 18 | 25 |
| McFarland | 1485 | | | | | 3 | 3 |
| Totals | | | 42 | 5 | 43 | 68 | 158 |

| Station | Sta. No. | Thru Departures | Local Departures | Thru Arrivals | Local Arrivals | Crew Changes | Total |
|--------------|----------|-----------------|------------------|---------------|----------------|--------------|-------|
| Bakersfield | 1511 | 134 | 411 | 158 | 367 | 2 | 1072 |
| Delano | 1479 | | | 23 | | | 23 |
| Gosford | 2709 | | 2 | | 2 | 6 | 10 |
| Stevens | 2715 | | 3 | | 2 | 3 | 8 |
| Rio Bravo | 2723 | | 1 | | | | 1 |
| Bowerbank | 2729 | | | | 1 | 1 | 2 |
| Buttonwillow | 2733 | | | 1 | | 2 | 3 |
| Gulf | 2812 | | 1 | | 1 | 4 | 6 |
| Millux | 2815 | 1 | | | | | 1 |
| Pentland | 2828 | | | | | 1 | 1 |
| Maricopa | 2832 | 1 | | | | 3 | 4 |
| Digiorgio | 2912 | | 2 | | 1 | | 3 |
| Arvin | 2917 | | 19 | | 19 | | 38 |
| Totals | | 136 | 439 | 182 | 393 | 22 | 1172 |
| Mojave | 1579 | | 163 | 2 | 166 | 13 | 344 |
| Monolith | 1563 | | 19 | | 17 | | 36 |
| Lancaster | 1604 | | 4 | | 6 | | 10 |
| Palmdale | 1612 | | 8 | | 6 | | 14 |
| Vincent | 1619 | | 1 | | 1 | | 2 |
| Honby | 1645 | 1 | | | 1 | | 2 |
| Creal | 1859 | | 21 | | 21 | | 42 |
| Searles | 3049 | | 32 | | 36 | | 68 |
| Lone Pine | 3139 | | 13 | | 13 | | 26 |
| Totals | | 1 | 261 | 2 | 267 | 13 | 544 |
| Porterville | 1773 | 13 | 42 | 15 | 42 | 1 | 113 |
| Lindsay | 1763 | | 18 | | 18 | | 36 |
| Ducor | 1785 | | | | | 1 | 1 |
| Richgrove | 1793 | 3 | 28 | 1 | 29 | 3 | 64 |
| Jasmin | 1797 | | | | 1 | 2 | 3 |
| Visalia | 2072 | | 6 | | 5 | 1 | 12 |
| Ultra | 2308 | | | | | 1 | 1 |
| Totals | | 16 | 94 | 16 | 95 | 9 | 230 |
| Jovista | 2504 | 1 | 31 | 1 | 28 | 26 | 87 |
| Trocha | 2503 | | | | | 1 | 1 |
| Totals | | 1 | 31 | 1 | 28 | 27 | 88 |
| Hanford | 2113 | 13 | 12 | 14 | 12 | 4 | 55 |
| Armona | 2116 | | 2 | 1 | 2 | 4 | 9 |
| Lemoore | 2121 | | | | | 3 | 3 |
| Rossi | 2123 | | 1 | | 1 | | 2 |
| Vanguard | 2131 | | | | | 1 | 1 |
| West Haven | 2133 | 1 | | | | | 1 |
| Huron | 2140 | 1 | | 1 | | 6 | 8 |
| Colinga | 2155 | | 1 | | 1 | 4 | 6 |
| Totals | | 15 | 16 | 16 | 16 | 22 | 85 |

| Station | Sta. No. | Thru Departures | Local Departures | Thru Arrivals | Local Arrivals | Crew Changes | Total |
|---------------------------|----------|-----------------|------------------|---------------|----------------|--------------|-------|
| Oxnard | 3337 | 4 | 106 | | 100 | | 210 |
| Ventura Jct. | 3327 | | 1 | | | | 1 |
| Ventura | 3328 | 2 | | | | | 2 |
| Montalvo | 3333 | | 2 | | 1 | | 3 |
| Somis | 3349 | 1 | 3 | | | | 4 |
| Santa Susanne | 3367 | | 4 | 2 | 6 | 3 | 15 |
| Ortonville | 3804 | | 4 | | 5 | | 9 |
| Ojai | 3815 | | 13 | | 14 | | 27 |
| Santa Paula | 3912 | | 11 | | 10 | | 21 |
| Piru | 3929 | | 15 | | 16 | | 31 |
| Totals | | | | | | | |
| Gemco | 3385 | | 27 | | 22 | | 49 |
| Chatsworth | 3375 | | 3 | | 3 | | 6 |
| North Ridge | 3379 | | 1 | | | | 1 |
| Raymer | 3383 | | 19 | 1 | 20 | | 40 |
| Totals | | | 50 | 1 | 45 | | 96 |
| Taylor | 3429 | 330 | 580 | 291 | 665 | | 1866 |
| Saugus | 1648 | | 6 | | 4 | | 10 |
| Tunnel | 3406 | | | | 1 | | 1 |
| San Fernando | 3411 | | 21 | | 18 | | 39 |
| Taylor Jct. | 3432 | | 1 | | | | 1 |
| Canoga Park | 3704 | | 11 | | 10 | | 21 |
| Tarzana | 3708 | | 4 | | 1 | | 5 |
| Encino | 3710 | | | | 1 | | 1 |
| Van Nuys | 3713 | | 1 | | 1 | | 2 |
| Los Angeles Spring St. | 3851 | 4 | 3 | | | | 7 |
| Mayo | 3940 | | 2 | | 1 | | 3 |
| Newhall Ranch | 3941 | | 3 | | 4 | | 7 |
| Pasadena | 3955 | | 4 | | 6 | | 10 |
| Totals | | 334 | 636 | 291 | 712 | | 1973 |
| Dolores | 3868 | | 41 | | | 24 | 65 |
| Patata | 4303 | | 1 | | | | 1 |
| Totals | | | 42 | | | 24 | 66 |
| Watson | | | | | 1 | | 1 |
| Wilmington | 3873 | | 23 | 24 | 16 | | 63 |
| Dolores | 3868 | | | | 27 | | 27 |
| San Pedro Front St. | 3875 | | | | 1 | | 1 |
| Totals | | | 23 | 24 | 45 | | 92 |
| Pomona | 4026 | | 3 | | 3 | | 6 |

| Station | Sta. No. | Thru Departures | Local Departures | Thru Arrivals | Local Arrivals | Crew Changes | Total |
|------------------|----------|-----------------|------------------|---------------|----------------|--------------|-------|
| City of Industry | 4013 | 19 | 166 | 20 | 163 | 74 | 442 |
| San Gabriel | 4003 | | 14 | | 14 | | 28 |
| El Monte | 4007 | 3 | 5 | 1 | 9 | 13 | 31 |
| Basselt | 4009 | | 13 | 5 | 5 | 2 | 25 |
| Marne | 4015 | 6 | 5 | 1 | 9 | | 21 |
| Totals | | 28 | 203 | 27 | 200 | 89 | 547 |
| Kaiser | 4039 | 4 | 30 | | 25 | | 59 |
| Colton | 4051 | 21 | 146 | 19 | 145 | 2 | 333 |
| Montclair | 4030 | | 11 | | 11 | | 22 |
| Montero | 4032 | | 16 | | 13 | | 29 |
| Riverside | 5007 | | 21 | | 21 | | 42 |
| Redlands | | | | | | | |
| 2nd Street | 5103 | | 3 | | 3 | | 6 |
| Cafton | 5107 | | 16 | | 16 | | 32 |
| South Fontana | 4042 | | | | 2 | | 2 |
| Totals | | 21 | 213 | 19 | 211 | 2 | 466 |
| Indio | 4123 | 6 | 151 | 15 | 145 | 431 | 748 |
| Thermal | 4130 | | 8 | 1 | 5 | | 14 |
| Thermal | 4132 | | | | 1 | | 1 |
| Mortmar | 4145 | | | | 2 | | 2 |
| Ferrum | 4152 | | 17 | | 15 | | 32 |
| Totals | | 6 | 176 | 16 | 168 | 431 | 797 |
| Yuma | 4245 | 91 | 116 | 114 | 97 | 318 | 736 |
| Somerton | 4715 | | | 1 | | | 1 |
| Sentinal | 5497 | | 1 | | | | 1 |
| Gila | 5523 | 15 | 21 | 16 | 19 | 420 | 491 |
| Totals | | 106 | 138 | 131 | 116 | 738 | 1129 |
| Norwalk | 4310 | 1 | 4 | 6 | | | 11 |
| Buena Park | 4315 | | | 1 | | | 1 |
| Totals | | 1 | 4 | 7 | | | 12 |
| Anaheim | 4321 | | | 11 | | | 11 |
| Santa Ana | 4328 | 5 | 30 | 2 | 31 | | 68 |
| Totals | | 5 | 30 | 13 | 31 | | 79 |
| Los Nietos | 4353 | 41 | 129 | 5 | 151 | 31 | 357 |
| El Centro | 4532 | 17 | 48 | 24 | 42 | | 131 |
| Calexiso | 4541 | | 1 | | 2 | | 3 |
| Niland | 4179 | | | 1 | | | 1 |
| Totals | | 17 | 49 | 25 | 44 | | 135 |

| Station | Sta. No. | Thru Departures | Local Departures | Thru Arrivals | Local Arrivals | Crew Changes | Total |
|---------------|----------|-----------------|------------------|---------------|----------------|--------------|-------|
| Tucson | 5651 | | | | | | |
| Shawmut | 5547 | | | | 1 | | 1 |
| Casa Grande | 5586 | | 12 | | 13 | | 25 |
| Toltec | 5596 | | 1 | | 1 | | 2 |
| Picacho | 5604 | | | | 2 | | 2 |
| Red Rock | 5619 | | | 1 | | | 1 |
| Rillito | 5634 | | 1 | | | | 1 |
| PFE Yard | 5654 | 121 | 134 | 145 | 128 | 312 | 840 |
| Bowic | 5735 | 7 | | | | | 7 |
| Sahuarita | 6719 | | 5 | | | | 5 |
| Continental | 6727 | | 1 | | | | 1 |
| Totals | | 128 | 154 | 146 | 145 | 312 | 885 |
| Benson | 5700 | 1 | 26 | | 26 | | 53 |
| Fairbank | 7561 | | | | 1 | | 1 |
| Maco | 7594 | | | | 18 | | 18 |
| | 7901 | | | | | | |
| | 7940 | | | | | | |
| Totals | | 1 | 26 | | 45 | | 72 |
| Bowie | 5765 | | 7 | | 3 | | 10 |
| San Carols | 6903 | | | 1 | | | 1 |
| Globe | 6923 | 1 | 16 | | | | 17 |
| Totals | | 1 | 23 | 1 | 3 | | 28 |
| Lordsburg | 5815 | 6 | 67 | 7 | 64 | 442 | 586 |
| Bowie | 5765 | | | 10 | | | 10 |
| Deming | 7060 | 1 | | | | | 1 |
| Clifton | 8470 | | 25 | | 24 | | 49 |
| Lawrence | 8505 | | 7 | | 8 | | 15 |
| Totals | | 7 | 99 | 17 | 96 | 442 | 661 |
| Phoenix Yard | 6037 | | 153 | | 149 | | 302 |
| Arlington | 5991 | | 1 | | 2 | | 3 |
| Dixie | 5996 | | 9 | | 9 | | 18 |
| Buckeye | 6006 | | 5 | | 5 | | 10 |
| Litchfield | 6020 | | 1 | | 1 | | 2 |
| Phoenix | 6036 | 1 | 10 | | 16 | | 27 |
| Aristuc | 6039 | | 1 | | 1 | | 2 |
| Tempe | 6044 | | 30 | | 29 | | 59 |
| Mesa | 6052 | | 14 | | 14 | | 28 |
| McQueen | 6054 | | 1 | | 1 | | 2 |
| Chandler | 6059 | | 2 | | 2 | | 4 |
| Litchfield | 6305 | | 4 | | 4 | | 8 |
| Helena | 6405 | | 13 | | 14 | | 27 |
| West Chandler | 6408 | | 1 | | 2 | | 3 |
| Gilbert | 6603 | | 6 | | 7 | | 13 |
| Higley | 6608 | | 1 | | | | 1 |
| Rittenhouse | 6615 | | 1 | | | | 1 |
| Totals | | 1 | 253 | | 256 | | 510 |

| Station | Sta. No. | Thru Departures | Local Departures | Thru Arrivals | Local Arrivals | Crew Changes | Total |
|------------------|-------------|--------------------|---------------------|------------------|-------------------|-----------------|-------|
| Hayden | 6677 | | 4 | | 3 | | 7 |
| Higley | 6608 | | 1 | | | | 1 |
| Rittenhouse | 6615 | | | | 1 | | 1 |
| Ray Jct. | 6664 | | 111 | | 110 | | 221 |
| Christmas | 6687 | | 4 | | 3 | | 7 |
| Totals | | | 120 | | 117 | | 237 |
| Nogales | 6766 | | 16 | | 15 | | 31 |
| Sahuarita | 6719 | | | | 5 | | 5 |
| Continental | 6727 | | | | 1 | | 1 |
| Totals | | | 16 | | 21 | | 37 |
| Globe | 6923 | | | | 8 | 24 | 32 |
| San Carlos | 6903 | | 1 | | | | 1 |
| Cutter | 6915 | 7 | | | 7 | 1 | 15 |
| Miami | 6934 | 10 | 2 | 14 | 7 | | 33 |
| Totals | | 17 | 3 | 14 | 22 | 25 | 81 |
| Carrizozo | 7291 | 1 | 11 | | 4 | 133 | 149 |
| Tucumcari | 7479 | 66 | 12 | 67 | 16 | | 161 |
| Santa Rosa | 7420 | | | | | 3 | 3 |
| Vernon | 8694 | | 1 | | 1 | | 2 |
| French | 8714 | | 8 | | 9 | | 17 |
| Totals | | 66 | 21 | 67 | 26 | 3 | 183 |
| Douglas | 7619 | | 46 | | 45 | | 91 |
| Fairbank | 7561 | | | | | 1 | 1 |
| Maco | 7594 | | 18 | | | | 18 |
| Bisbee Jct. | 7597 | | 2 | | 2 | | 4 |
| Ft. Huachuca | 8213 | | 1 | 1 | | | 2 |
| Totals | | | 67 | 1 | 47 | 1 | 116 |
| Rodeo | 8822 | | 15 | | 15 | | 30 |
| Martinez | 8831 | | | | | | |
| Crockett | 8825 | | 1 | | 1 | | 2 |
| Suisan Fairfield | 8848 | 12 | 11 | | 21 | | 44 |
| Elmira | 8859 | | 1 | | | | 1 |
| Dixon | 8867 | | 1 | | | | 1 |
| Childs | 8876 | | | | 1 | | 1 |
| Webster | 8880 | | 5 | | 7 | | 12 |
| Vacarille | 10304 | | 1 | 1 | | | 2 |
| Winters | 10316 | | 6 | 7 | | | 13 |
| Madison | 10327 | | 1 | 1 | | | 2 |
| Esparto | 10330 | | 6 | 3 | 2 | | 11 |
| Totals | | 12 | 32 | 12 | 31 | | 87 |

| Station | Sta. No. | Thru Departures | Local Departures | Thru Arrivals | Local Arrivals | Crew Changes | Total |
|-----------------|----------|-----------------|------------------|---------------|----------------|--------------|-------|
| West Oakland | 8901 | 5 | 592 | 22 | 567 | 74 | 1260 |
| Davis | 8875 | 2 | 48 | 16 | 32 | 56 | 154 |
| Totals | | 7 | 640 | 38 | 599 | 130 | 1414 |
| Sacramento | 8889 | 3 | 184 | 1 | 171 | 2 | 361 |
| Placerville | 12055 | | 26 | | | | 26 |
| Freeport | 12109 | | 3 | | 3 | | 6 |
| Walnut Grove | 12125 | | 9 | | 9 | | 18 |
| Isleton | 12133 | | 9 | | 9 | | 18 |
| Totals | | 3 | 231 | 1 | 192 | 2 | 429 |
| Hayward | 8917 | | 35 | | 28 | | 63 |
| Niles | 8926 | | 56 | | 58 | | 114 |
| Totals | | | 91 | | 86 | | 177 |
| Niles | 8926 | | | | | | |
| Niles Tower | 9701 | | 1 | | | | 1 |
| Milpitas | 9712 | | 5 | | 2 | | 7 |
| Totals | | | 6 | | 2 | | 8 |
| East Pleasanton | 8940 | | 16 | 1 | 35 | | 52 |
| Livermore | 8943 | | 45 | | 46 | | 91 |
| Totals | | | 61 | 1 | 81 | | 143 |
| Tracy | 8967 | 2 | 515 | 4 | 518 | 7 | 1046 |
| Brentwood | 9127 | | 29 | | 27 | | 56 |
| Patterson | 9163 | | 3 | | 2 | | 5 |
| Crowa Landing | 9179 | | 2 | 1 | 1 | 1 | 5 |
| Newmon | 9185 | 2 | 6 | 1 | 5 | | 13 |
| Totals | | 4 | 555 | 6 | 553 | 8 | 1125 |
| Stockton | 8987 | 1 | 35 | 1 | 28 | 1 | 66 |
| Walt Hall | 10507 | | 1 | | 1 | | 2 |
| Dakdole | 10532 | | 7 | | 7 | | 14 |
| Waterford | 10542 | | 11 | | 12 | | 23 |
| Montpeiller | 10549 | | 3 | | 2 | | 5 |
| Totals | | 1 | 57 | 1 | 50 | 1 | 110 |
| Lodi | 9000 | 1 | 74 | | 71 | 1 | 147 |
| Acompo | 9003 | | 17 | | 16 | | 33 |
| Polk | 9029 | | | | 2 | | 2 |
| Victor | 10604 | | 1 | | 1 | | 2 |
| Lockeford | 10607 | | 2 | | 2 | | 4 |
| Toyon | 10631 | | 1 | | 1 | | 2 |
| Kentucky House | 10639 | | 14 | | 13 | | 27 |
| Ione | 10727 | | 17 | | 17 | 1 | 35 |
| Totals | | 1 | 126 | | 123 | 2 | 252 |

| Station | Sta. No. | Thru Departures | Local Departures | Thru Arrivals | Local Arrivals | Crew Changes | Total |
|--------------|----------|-----------------|------------------|---------------|----------------|--------------|-------|
| Port Chicago | 9107 | 3 | 43 | 1 | 58 | 105 | 210 |
| Mococo | 9101 | | 1 | | 1 | 3 | 5 |
| Pittsburgh | 9114 | | 28 | | 17 | 1 | 46 |
| Concord | 10404 | | 1 | | 1 | 1 | 3 |
| Walnut Creek | 10410 | | 10 | 2 | 7 | | 19 |
| Danville | 10417 | | 2 | | 4 | | 6 |
| Totals | | 3 | 85 | 3 | 88 | 110 | 289 |
| Los Benos | 9206 | 1 | 22 | | 24 | 2 | 49 |
| Modesto | 9420 | 25 | 24 | 22 | 15 | | 86 |
| Salida | 9414 | | | | | 1 | 1 |
| Turlock | 9433 | 1 | 3 | | 1 | 47 | 52 |
| Totals | | 26 | 27 | 22 | 16 | 48 | 139 |
| Merced | 9458 | 23 | 2 | 26 | 3 | | 54 |
| Livingston | 9444 | | | | 1 | | 1 |
| Creegan | 9459 | | | | | 9 | 9 |
| Athlone | 9468 | | | | | 1 | 1 |
| Chowchilla | 9475 | | | | | 2 | 2 |
| Totals | | 23 | 2 | 26 | 4 | 12 | 67 |
| Mulford | 9602 | | 18 | | 18 | | 36 |
| Mt. Eden | 9608 | | | | | 1 | 1 |
| Alvarado | 9612 | | 16 | | | | 16 |
| Totals | | | 34 | | 18 | 1 | 53 |
| Newark | 9617 | | 57 | 1 | 39 | 1 | 98 |
| Alvarado | 9612 | | | | 15 | | 15 |
| Totals | | | 57 | 1 | 54 | 1 | 113 |
| Lombard | 9914 | | 62 | 1 | 61 | | 124 |
| Napa Jct. | 9913 | | 4 | | 3 | | 7 |
| Rocktram | 10006 | | | | 1 | | 1 |
| Krug | 10027 | | 4 | | 4 | | 8 |
| Calistoga | 10035 | | 10 | | 10 | | 20 |
| West Napa | 10102 | | 2 | | 2 | | 4 |
| Flosden | 10203 | | 1 | | 1 | | 2 |
| Vallejo | 10207 | | 19 | | 20 | 1 | 40 |
| Totals | | | 102 | 1 | 102 | 1 | 206 |
| Schellville | 9925 | | 94 | 1 | 81 | | 176 |
| Sparks | 11455 | 69 | 328 | 217 | 184 | 304 | 1102 |
| Truckee | 11417 | | | | | 2 | 2 |
| Lovelock | 12298 | | | | 11 | | 11 |
| Fallon | 14116 | | 8 | | 7 | | 15 |
| Totals | | 69 | 336 | 217 | 202 | 306 | 1130 |

| Station | Sta. No. | Thru Departures | Local Departures | Thru Arrivals | Local Arrivals | Crew Changes | Total |
|-----------------|----------|------------------|------------------|------------------|------------------|----------------|-------------|
| Roseville | 11318 | 559 ^E | 816 ^E | 416 ^H | 963 ^H | 4 ^H | 2758 |
| Bowman | 11340 | | 24 ^H | | 5 ^H | | 29 |
| Colfox | 11353 | | | | 1 ^H | | 1 |
| Norden | 11402 | | | | | 1 ^H | 1 |
| Bowman | 11518 | | 1 ^H | | 19 ^H | | 20 |
| Lincoln | 11610 | | 28 ^Y | | 26 ^Y | | 54 |
| Erle | 11625 | | 4 ^Y | | | | 4 |
| Durham | 11672 | | 1 ^H | | | 6 ^H | 7 |
| Chico | 11678 | | | 6 ^H | 13 ^H | 7 ^H | 26 |
| Butle Creek | 12804 | | | | | 1 ^H | 1 |
| Stirling City | 12831 | | | | | 5 ^H | 5 |
| Totals | | 559 | 874 | 422 | 1027 | 24 | 2906 |
| Marysville | 11634 | | 40 | 1 | 45 | | 86 |
| Berg | | | | | | 1 | 1 |
| Sunset | 11643 | | 1 | | | | 1 |
| Live Oak | 11645 | | 3 | | 2 | 1 | 6 |
| Wilson | 12514 | | 3 | | | | 3 |
| Oroville | 12625 | | | | 1 | | 1 |
| Totals | | | 47 | 1 | 48 | 2 | 98 |
| Gerber | 11707 | 44 | 181 | 23 | 168 | 376 | 792 |
| Chico | 11678 | 6 | 13 | | | | 19 |
| Nord | 11685 | | 1 | | | 2 | 3 |
| Grimes | 12213 | | | | | 15 | 15 |
| Colusa | 12225 | | | | | 1 | 1 |
| Ord Bend | 12254 | | 2 | | 2 | | 4 |
| Hamilton | 12262 | | 17 | 1 | 17 | | 35 |
| Totals | | 50 | 214 | 24 | 187 | 394 | 869 |
| Woodland | 11809 | 15 | 61 | 15 | 90 | 5 | 186 |
| Merritt | 11805 | 1 | | | | | 1 |
| Yolo | 11814 | | 1 | | 1 | | 2 |
| Sugerfield | 12403 | | 1 | | 1 | | 2 |
| Knights Landing | 12409 | | 2 | | 2 | | 4 |
| Totals | | 16 | 65 | 15 | 94 | 5 | 195 |
| Placerville | 12055 | | 26 | | | | 26 |
| Fernley | 12930 | 14 | 16 | 21 | 10 | 126 | 187 |
| Imloy | 13038 | 18 | 56 | 33 | 33 | 672 | 812 |
| Lovelock | 12998 | | 11 | | | | 11 |
| Mill City | 13043 | | | 1 | | | 1 |
| Totals | | 18 | 67 | 34 | 33 | 672 | 824 |

| Station | Sta. No. | Thru Departures | Local Departures | Thru Arrivals | Local Arrivals | Crew Changes | Total |
|----------------|-------------|--------------------|---------------------|------------------|-------------------|-----------------|-------|
| Carlin | 13614 | 30 | 170 | 31 | 43 | 428 | 702 |
| Carlin | 13183 | | 38 | 138 | 16 | 81 | 273 |
| Wells | 13256 | | 1 | | | | 1 |
| Lakeside | 13383 | | 1 | | 1 | | 2 |
| Totals | | 30 | 210 | 169 | 60 | 509 | 978 |
| Wendel | 13783 | 10 | 32 | 16 | 39 | 163 | 260 |
| Susanville | 14223 | | 5 | | 6 | | 11 |
| Totals | | 10 | 37 | 16 | 45 | 163 | 271 |
| Ogden | 13431 | 333 | 41 | 175 | 198 | | 747 |
| Alturas | 13881 | 12 | 15 | 22 | 44 | 147 | 280 |
| Canby | 14819 | | 13 | | 12 | | 25 |
| Lakeview | 14956 | | 13 | | 13 | | 26 |
| Totals | | 12 | 41 | 22 | 69 | 147 | 331 |
| Mina | 14029 | | 28 | | 25 | | 53 |
| Luning | 14020 | | | | 1 | | 1 |
| Totals | | | 28 | | 26 | | 54 |
| Redding | 14344 | 1 | 68 | 19 | 44 | | 132 |
| Red Bluff | 14310 | | | | 1 | | 1 |
| Culp | 14330 | | 16 | | 16 | | 32 |
| Anderson | 14333 | 1 | 3 | | 3 | | 7 |
| Central Valley | 14353 | | 1 | | 1 | 17 | 19 |
| Gray Rocks | 14357 | | 1 | | 1 | 2 | 4 |
| Middle Creek | 14653 | | | | 1 | | 1 |
| Kesdam | 14654 | | | | 1 | | 1 |
| Kett | 14655 | | 2 | | 5 | | 7 |
| Mofhenson | 14659 | | 3 | | | 1 | 4 |
| Totals | | 2 | 94 | 19 | 73 | 20 | 208 |
| Dunsmuir Yard | 14401 | 37 | 107 | 37 | 135 | 376 | 692 |
| Cantara | 14407 | 2 | 1 | | | | 3 |
| Deetz | 14421 | | 2 | | 2 | | 4 |
| Black Butte | 14424 | | 2 | | 26 | 6 | 34 |
| Totals | | 39 | 112 | 37 | 163 | 382 | 733 |
| Crescent Lake | 14608 | 17 | 23 | 12 | 44 | 456 | 552 |

| Station | Sta. No. | Thru Departures | Local Departures | Thru Arrivals | Local Arrivals | Crew Changes | Total |
|------------------|-------------|--------------------|---------------------|------------------|-------------------|-----------------|-------|
| Klamath Falls | 14509 | 158 | 78 | 154 | 104 | 356 | 850 |
| Grass Lake | 14447 | | | | 1 | | 1 |
| Kegg | 14465 | | 10 | | 10 | | 20 |
| Mt. Helnon | 14473 | | 2 | | 2 | | 4 |
| MacDoel | 14476 | | 3 | | 3 | | 6 |
| Somerset | 14477 | | 1 | | 1 | | 2 |
| Dorris | 14486 | 1 | 3 | | 2 | | 6 |
| Texum | 14508 | 2 | 1 | 1 | | | 4 |
| Chiloquin | 14536 | | 18 | | 20 | | 38 |
| Copic | 14862 | | 2 | | 2 | | 4 |
| Staley | 14864 | | 8 | | 8 | | 16 |
| Stronghold | 14866 | | 2 | | 2 | | 4 |
| Tule Lake | 14871 | | 2 | | 2 | | 4 |
| Lost River | 14883 | | | | 2 | | 2 |
| Totals | | 161 | 130 | 155 | 159 | 356 | 961 |
| Weed | 14704 | | 14 | | 14 | | 28 |
| Montague | 14732 | | 12 | | 11 | | 23 |
| Hilt | 14758 | | 9 | | 9 | | 18 |
| Totals | | | 21 | | 20 | | 41 |
| Ashland | 14785 | 35 | 140 | 31 | 123 | | 329 |
| Oak Ridge | 15052 | | | | 25 | | 25 |
| Eugene Yard | 15097 | 264 | 558 | 220 | 567 | 54 | 1663 |
| Oak Ridge | 15052 | | 26 | | | | 26 |
| Crale | 15067 | | 1 | | | | 1 |
| Springfield Jct. | 15092 | | 1 | | | | 1 |
| Divide | 15493 | | 1 | | 1 | | 2 |
| Kenwood | 15495 | | | | 1 | | 1 |
| Cottage Grove | 15497 | | 42 | | 36 | | 78 |
| Danebo | 15603 | | 2 | | 1 | | 3 |
| Vaughn | 15620 | | 1 | | 1 | | 2 |
| Mapleton | 15657 | | 10 | | 8 | | 18 |
| Reedspport | 15692 | | 1 | | | | 1 |
| Totals | | 264 | 643 | 220 | 615 | 54 | 1796 |
| Springfield | 15091 | | 63 | | 56 | | 119 |

| Station | Sta. No. | Thru Departures | Local Departures | Thru Arrivals | Local Arrivals | Crew Changes | Total |
|---------------|----------|-----------------|------------------|---------------|----------------|--------------|-------|
| Roseburg | 15444 | | 188 | | 174 | 44 | 406 |
| Cornutt | 15411 | | 12 | | 12 | | 24 |
| Riddle | 15415 | | 3 | | 3 | | 6 |
| Myrtle Creek | 15421 | 4 | 16 | | 21 | | 41 |
| Dillard | 15433 | 11 | 11 | | 21 | | 43 |
| Sutherlin | 15457 | | 2 | | 3 | | 5 |
| Totals | | 15 | 232 | | 234 | 44 | 525 |
| Coos Bay | 15721 | | 59 | 2 | 54 | 20 | 135 |
| Coquille | 15738 | 5 | 23 | | | | 28 |
| Norway | 15744 | 1 | | | 1 | | 2 |
| Myrtle Point | 15746 | 1 | 2 | | | | 3 |
| Totals | | 7 | 84 | 2 | 55 | 20 | 168 |
| Albany | 15139 | 26 | 138 | 20 | 140 | | 324 |
| Brownsville | 15927 | | | | 1 | | 1 |
| Tallman | 15940 | 1 | 27 | | 6 | 20 | 54 |
| Irvanville | 15941 | | 2 | | 1 | | 3 |
| Lebanon | 15944 | | 22 | | 40 | | 62 |
| Monroe | 16409 | 1 | 4 | | 3 | 1 | 9 |
| Dry Creek | 16422 | 1 | 2 | | 1 | | 4 |
| Wigrich | 16445 | | | 1 | | | 1 |
| Independence | 16447 | | 11 | | 7 | | 18 |
| Dawson | 16605 | 4 | 5 | | 1 | 1 | 11 |
| Totals | | 33 | 211 | 21 | 200 | 22 | 487 |
| Salem | 15167 | | 48 | 10 | 46 | | 104 |
| Pringle | 15165 | | 21 | 7 | 40 | | 68 |
| Marion | 15152 | | 1 | | 1 | | 2 |
| Salem | 15166 | | 5 | | 6 | | 11 |
| Woodburn | 15183 | | 7 | | 7 | | 14 |
| West Stayton | 15963 | | 1 | | 1 | | 2 |
| Geer | 15974 | | 1 | | 1 | | 2 |
| Gerlinger | 16452 | 1 | 1 | | 1 | 2 | 5 |
| Dallas | 16816 | | 16 | | 14 | | 30 |
| Falls City | 16825 | | 1 | | 1 | | 2 |
| Black Rock | 16829 | | 11 | | 11 | | 22 |
| Totals | | 1 | 113 | 17 | 129 | 2 | 262 |
| Medford | 15313 | | 69 | 2 | 59 | | 130 |
| Central Point | 15317 | | 1 | | | | 1 |
| White City | 16656 | | 9 | | 9 | | 18 |
| Totals | | | 79 | 2 | 68 | | 149 |

| Station | Sta. No. | Thru Departures | Local Departures | Thru Arrivals | Local Arrivals | Crew Changes | Total |
|----------------|----------|-----------------|------------------|---------------|----------------|--------------|-------|
| Brooklyn | 15215 | 63 | 390 | 64 | 409 | 1 | 927 |
| Canby | 15195 | | 18 | | 16 | | 34 |
| New Era | 15198 | | | | 2 | | 2 |
| Coalea | | | 1 | | 1 | | 2 |
| Polk | 15201 | | 11 | | 10 | | 21 |
| Oregon City | 15203 | | 1 | | 1 | | 2 |
| Clackamus | 15208 | | 18 | 1 | 16 | | 35 |
| Molalla | 16210 | | 12 | | 11 | | 23 |
| Beaverton | 17215 | 1 | 17 | | | | 18 |
| Portland | | | | | | | |
| Jefferson St. | 17407 | | 23 | | 23 | | 46 |
| Totals | | 64 | 491 | 65 | 489 | 1 | 1110 |
| Medford | 15313 | | 69 | 2 | 59 | | 130 |
| Central Point | 15317 | | 1 | | | | 1 |
| White City | 16656 | | 9 | | 9 | | 18 |
| Totals | | | 79 | 2 | 68 | | 149 |
| Grants Pass | 15345 | 1 | 47 | 1 | 45 | | 94 |
| Gold Hill | 15238 | | | | 1 | 1 | 2 |
| Rock Point | 15330 | | | | | 1 | 1 |
| Roque River | 15336 | | | | 4 | 1 | 5 |
| Glendale | 15379 | | 4 | 1 | 5 | 1 | 11 |
| Eyers | 15406 | | 1 | | | | 1 |
| Totals | | 1 | 52 | 2 | 55 | 4 | 114 |
| Coquille | 15738 | | | | 27 | 16 | 43 |
| Johnson | 15740 | | 1 | | 1 | | 2 |
| Myrtle Point | 15746 | | | | 2 | | 2 |
| Powers | 15765 | 1 | 2 | | 20 | | 37 |
| Totals | | 1 | 3 | | 50 | 16 | 84 |
| Libanon | 15944 | | | | | 35 | 35 |
| Griggs | 15949 | 7 | 12 | | 1 | | 20 |
| Shelburn | 15960 | | 1 | | 1 | | 2 |
| Fawn | 16115 | | 1 | 1 | 1 | | 3 |
| Mill City | 16122 | 6 | 11 | 23 | 1 | | 41 |
| Totals | | 13 | 25 | 24 | 4 | 35 | 101 |
| Toledo | 16375 | | 33 | | 31 | | 64 |
| Corvallis | 16426 | | 25 | | 24 | 8 | 57 |
| Flynn | 16319 | | 2 | | 2 | | 4 |
| Blodgett | 16332 | | 7 | | 8 | | 15 |
| Corvallis Jct. | 16427 | | 1 | | | 1 | 2 |
| Wrens | 16325 | | 4 | | 5 | | 9 |
| Totals | | | 39 | | 39 | 9 | 87 |

| Station | Sta. No. | Thru Departures | Local Departures | Thru Arrivals | Local Arrivals | Crew Changes | Total |
|-------------|-------------|--------------------|---------------------|------------------|-------------------|-----------------|-------|
| McMinnville | 16473 | | 20 | | 22 | 32 | 74 |
| Whikson | 16468 | | 1 | | | | 1 |
| Sheridan | 16914 | 1 | | | 1 | | 2 |
| Shipley | 16916 | 1 | | | | | 1 |
| Willamina | 16919 | 6 | 22 | 21 | 3 | | 52 |
| Totals | | 8 | 43 | 21 | 26 | 32 | 130 |
| | | | | | | | |
| Hillsboro | 16502 | | 23 | | 6 | | 29 |
| Seghers | 16493 | | 2 | | 1 | | 3 |
| Totals | | | 25 | | 7 | | 32 |
| | | | | | | | |
| Wheeler | 17293 | | 10 | | 9 | 41 | 60 |
| Reedville | 17219 | | | | 1 | | 1 |
| Tillamook | 17315 | 13 | 10 | 26 | | | 49 |
| Totals | | 13 | 20 | 26 | 10 | 41 | 110 |

TRAIN STATISTICS - TEXAS AND LOUISIANA LINES (OCTOBER 1960)

| Station | Sta. No. | Thru Departures | Local Departures | Thru Arrivals | Local Arrivals | Crew Changes | Total |
|---------------|-------------|--------------------|---------------------|------------------|-------------------|-----------------|-------|
| Hempstead | 30050 | | 13 | | 13 | | 26 |
| Hearne | 30120 | 304 | 39 | 291 | 47 | 25 | 756 |
| Ennis (YO) | 30231 | 200 | 67 | 200 | 65 | | 532 |
| McKinney | 30295 | 1 | 25 | | 26 | | 52 |
| Totals | | 201 | 92 | 200 | 91 | | 584 |
| Miller | 30258 | | 13 | | 13 | | 26 |
| Commerce | 47588 | | 26 | | 25 | | 51 |
| Paris | 47625 | | 23 | | 24 | | 47 |
| Totals | | | 62 | | 62 | | 124 |
| Sherman | 30328 | 1 | 1 | | 1 | | 3 |
| Denison | 30337 | 29 | 1 | 30 | 2 | | 62 |
| STLSW Yard | | | | | | | |
| East Waco | 31187 | 22 | 30 | 25 | 26 | | 103 |
| Cameron | 37239 | | 25 | 2 | 24 | | 51 |
| Totals | | 22 | 55 | 27 | 50 | | 154 |
| Fort Worth | 32285 | 29 | 26 | 31 | 26 | | 112 |
| Giddings | 33106 | 1 | 12 | | 12 | | 25 |
| Austin | 33165 | 10 | 39 | 16 | 40 | | 105 |
| Llano | 33264 | | 26 | | 25 | | 51 |
| Totals | | 10 | 65 | 16 | 65 | | 156 |
| Lufkin | 40119 | 14 | 75 | 11 | 79 | 55 | 234 |
| Shreveport | 40233 | 34 | 26 | 35 | 20 | | 115 |
| Pasadena | 41369 | | 32 | | 31 | | 63 |
| Deer Park | 41374 | | 4 | | 4 | | 8 |
| Strang | 41379 | | 31 | | 31 | | 62 |
| Totals | | | 67 | | 66 | | 133 |
| Galveston | 41412 | 29 | | 24 | 1 | | 54 |
| Jacksonville | 45449 | | 49 | | 49 | | 98 |
| Nacooa Doches | 45399 | | 29 | | 31 | | 60 |
| | 46475 | | 8 | | 7 | | 15 |
| Totals | | | 86 | | 87 | | 173 |

| Station | Sta. No. | Thru Departures | Local Departures | Thru Arrivals | Local Arrivals | Crew Changes | Total |
|--------------------|----------|-----------------|------------------|---------------|----------------|--------------|-------|
| Baytown | 48350 | | 27 | | 25 | | 52 |
| Dayton | 70327 | 1 | 27 | 1 | 29 | | 58 |
| Totals | | 1 | 54 | 1 | 54 | | 110 |
| Victoria Frt. Yard | 50489 | 83 | 37 | 75 | 39 | 26 | 260 |
| Stockdale | 51566 | | 13 | | 13 | | 26 |
| Port Lavaca | 54518 | | 8 | | 9 | | 17 |
| Rosenberg | 70399 | | | | 19 | | 19 |
| Totals | | 83 | 58 | 75 | 80 | 26 | 322 |
| Wharton | 50425 | 1 | 26 | 1 | 26 | | 54 |
| Bay City | 53460 | | 5 | | 5 | | 10 |
| Markham | 53467 | | 6 | | 6 | | 12 |
| Blessing | 53480 | | 6 | | 5 | | 11 |
| Palacios | 53492 | | 9 | | 9 | | 18 |
| Totals | | 1 | 52 | 1 | 51 | | 105 |
| Yoakum | 55121 | | 36 | | 39 | | 75 |
| Cuero | 55138 | | 10 | | 9 | | 19 |
| Runge | 55170 | | 1 | | 1 | | 2 |
| Kenedy | 55180 | 2 | 14 | 2 | 15 | | 33 |
| Totals | | 2 | 61 | 2 | 64 | | 129 |
| Skidmore | 56223 | 4 | 10 | 5 | 10 | | 29 |
| Gregory | 56257 | 1 | 23 | | 25 | | 49 |
| Kosmos | 57271 | | 12 | 1 | 10 | | 23 |
| Rockport | 57278 | | 12 | | 12 | | 24 |
| Totals | | 1 | 47 | 1 | 47 | | 96 |
| Corpus Christi | 56268 | 50 | 1 | 47 | | | 98 |
| Alice | 58266 | 7 | 13 | 10 | 13 | 54 | 97 |
| Edinburg Yard | 58364 | | 28 | | 29 | | 57 |
| McAllen | 58375 | | 29 | | 27 | | 56 |
| Brownsville | 59429 | 32 | | 31 | | | 63 |
| Gonzales | 60519 | | 25 | | 26 | | 51 |
| Harwood | 70507 | | 27 | | 26 | | 53 |
| Totals | | | 52 | | 52 | | 104 |

| Station | Sta. No. | Thru Departures | Local Departures | Thru Arrivals | Local Arrivals | Crew Changes | Total |
|-----------------|----------|-----------------|------------------|---------------|----------------|--------------|-------|
| Eagle Pass | 61738 | | 31 | | 30 | | 61 |
| Avondale | 70012 | 91 | 26 | 95 | 26 | | 238 |
| Raceland Jct. | 70040 | | 54 | | 55 | | 109 |
| Raceland | 73042 | | 29 | | 27 | | 56 |
| Lockport | 73050 | | 27 | | 27 | | 54 |
| Totals | | | 110 | | 109 | | 219 |
| Schriever | 70055 | | 56 | | 53 | | 109 |
| Supreme | 74067 | | 4 | | 4 | | 8 |
| Napoleonville | 74077 | | 24 | | 26 | | 50 |
| Houma | 75070 | 1 | 25 | | 26 | | 52 |
| Totals | | 1 | 109 | | 109 | | 219 |
| Morgan City | 70080 | | 53 | | 52 | | 105 |
| Baldwin | 70105 | | 54 | | 51 | | 105 |
| Weeks | 77124 | | 50 | | 53 | | 103 |
| Totals | | | 104 | | 104 | | 208 |
| New Iberia | 70126 | | 52 | 1 | 49 | | 102 |
| Pesson | 79125 | | 19 | | 19 | | 38 |
| Lozes | 79136 | | 2 | | 2 | | 4 |
| Youngsville | 79140 | | 20 | | 21 | | 41 |
| Davids | 81130 | | 8 | | 7 | | 15 |
| Salt Mine | 81136 | 1 | 37 | | 38 | | 76 |
| Totals | | 1 | 138 | 1 | 136 | | 276 |
| Lafayette | 70147 | 68 | 118 | 50 | 122 | 111 | 469 |
| Crowley | 70167 | 8 | 11 | 9 | 8 | | 36 |
| Arnoudville | 83162 | | 8 | | 8 | | 16 |
| Ruth | 84155 | | 1 | | 1 | | 2 |
| Parks | 84159 | | 1 | | 2 | | 3 |
| St. Martinville | 84166 | | 21 | | 22 | | 43 |
| Anse La Butte | 85150 | | 1 | | 1 | | 2 |
| Breaux Bridge | 85153 | 1 | 39 | | 40 | | 80 |
| Opelousas | 86167 | | 26 | | 25 | | 51 |
| Whiteville | 86187 | | | | 1 | | 1 |
| Totals | | 77 | 226 | 59 | 230 | 111 | 703 |
| Echo | 70251 | 10 | | 12 | | 114 | 136 |
| Eagle Lake | 70432 | 1 | | 1 | | | 2 |
| Jayray | 70440 | 2 | | 2 | | | 4 |
| Totals | | 3 | | 3 | | | 6 |

| Station | Sta. No. | Thru Departures | Local Departures | Thru Arrivals | Local Arrivals | Crew Changes | Total |
|-------------------|-------------|--------------------|---------------------|------------------|-------------------|-----------------|-------|
| Englewood | 70358 | 283 | 110 | 268 | 119 | | 780 |
| Sinco | 41367 | | 2 | | 1 | | 3 |
| La Porte | 41381 | | 19 | | 19 | | 38 |
| Texas City Jct. | 41404 | 1 | 6 | | 8 | | 15 |
| Houston Frt. Sta. | 70361 | 1 | | 6 | | | 7 |
| Rosenberg | 70399 | | 20 | | | | 20 |
| Needville | 52411 | | 3 | | 4 | | 7 |
| Guy | 52416 | | 12 | | 12 | | 24 |
| Long Point | 52421 | | 13 | | 12 | | 25 |
| Totals | | 285 | 185 | 274 | 175 | | 919 |
| Glidden | 70450 | 33 | 51 | 28 | 49 | 106 | 267 |
| East Yard | | | | | | | |
| (San Antonio) | 70571 | 347 | 88 | 345 | 87 | | 867 |
| Camp Stanley | 55267 | | 7 | | 6 | | 13 |
| Buerne | 55277 | | 1 | | 1 | | 2 |
| Comfort | 55298 | | 3 | | 3 | | 6 |
| Center Point | 55306 | | 1 | | 1 | | 2 |
| Kerrville | 55316 | | 14 | | 14 | | 28 |
| Totals | | 347 | 114 | 345 | 112 | | 918 |
| Spofford | 70705 | | 54 | | 57 | | 111 |
| Del Rio | 70742 | 36 | | 21 | | 281 | 338 |
| Sanderson | 70870 | 36 | 1 | 39 | | 266 | 342 |
| Valentine | 71022 | 26 | | 26 | | 280 | 332 |
| Alfalfa | 71176 | | | 101 | | | 101 |
| El Paso | 71181 | 146 | | 56 | | | 202 |
| Deming | 7060 | | | | 1 | | 1 |
| Totals | | 146 | | 56 | 1 | | 203 |
| Eunice | 82205 | | 25 | | 28 | | 53 |
| Alexandria | 86230 | | 31 | | 31 | | 62 |
| Lake Charles | 70219 | 1 | 86 | 1 | 88 | | 176 |
| Holmwood | 87225 | | 3 | | 3 | | 6 |
| Lake Arthur | 87248 | | 17 | | 18 | | 35 |
| DeRidder | 88263 | | 14 | | 14 | | 28 |
| Totals | | 1 | 120 | 1 | 123 | | 245 |

| Station | Sta. No. | Thru Departures | Local Departures | Thru Arrivals | Local Arrivals | Crew Changes | Total |
|------------------|-------------|--------------------|---------------------|------------------|-------------------|-----------------|-------|
| Beaumont | 70278 | 10 | 168 | 17 | 163 | | 358 |
| West Port Arthur | 43296 | | 6 | | 5 | | 11 |
| Port Arthur | 43299 | | 46 | | 48 | | 94 |
| Chaison | 44286 | | 30 | | 28 | | 58 |
| Orange | 70257 | | 29 | | 29 | | 58 |
| Totals | | 10 | 279 | 17 | 273 | | 579 |

COMPILED SUMMARY OF 2619 REPORTS ASSIGNED TO ACCOUNTING LOCATIONS
INDICATING TOTAL CARLOADS FORWARDED (CL) AND PIGGYBACK (PB) FOR-
WARDED FOR THE YEAR 1960*

| STATION | | PACIFIC LINES | | | | | | | | | | | |
|---------------|-----|---------------|------|------|------|-------|------|------|-------|------|------|------|------|
| | | JAN | FEB | MAR | APR | MAY | JUNE | JULY | AUG | SEPT | OCT | NOV | DEC |
| San Francisco | C/L | 3170 | 2773 | 3296 | 3168 | 3293 | 3357 | 3540 | 3384 | 3068 | 2858 | 2725 | 2699 |
| Niles | C/L | 1422 | 1644 | 2380 | 2541 | 2264 | 2580 | 2349 | 2444 | 2148 | 2516 | 2108 | 1913 |
| Oakland | C/L | 8759 | 8946 | 9920 | 9938 | 10233 | 9805 | 9738 | 10383 | 9677 | 9275 | 8165 | 7608 |
| | P/B | 1143 | 1193 | 1308 | 1309 | 1204 | 1192 | 1366 | 1093 | 1050 | 1420 | 1562 | 1420 |
| Tracy | C/L | 2851 | 2635 | 3446 | 3053 | 2869 | 3170 | 5521 | 6640 | 5154 | 5581 | 2987 | 2625 |
| Fresno | C/L | 3002 | 2593 | 2343 | 2451 | 3013 | 3591 | 6175 | 4207 | 3690 | 4403 | 2856 | 2978 |
| Stockton | C/L | 930 | 1059 | 1304 | 1227 | 1130 | 1379 | 1380 | 1435 | 1486 | 1559 | 1284 | 940 |
| | P/B | 50 | 54 | 54 | 59 | 76 | 79 | 61 | 94 | 47 | 42 | 30 | 24 |
| Sacramento | C/L | 1889 | 2030 | 2066 | 1984 | 2068 | 2177 | 2874 | 2449 | 3644 | 2631 | 2229 | 1688 |
| Roseville | C/L | 3755 | 3712 | 4657 | 4087 | 3624 | 4699 | 6888 | 6109 | 5530 | 4839 | 3922 | 3861 |
| Gerber | C/L | 1375 | 1494 | 1632 | 1764 | 1518 | 1585 | 1426 | 2107 | 1943 | 1917 | 1601 | 1134 |
| | P/B | 7 | 4 | 6 | 2 | 8 | 3 | 5 | 6 | 3 | 3 | 3 | 6 |
| Schellville | C/L | 365 | 339 | 384 | 226 | 214 | 210 | 404 | 330 | 287 | 281 | 287 | 329 |

(Also N. W. P.
Terminal)

*WHERE ONLY ONE MONTH VOLUME IS SHOWN FOR PIGGYBACK VOLUME
IS FOR THE YEAR 1961.

PACIFIC LINES

| STATION | JAN | FEB | MAR | APR | MAY | JUNE | JULY | AUG | SEPT | OCT | NOV | DEC |
|---|-----------|-------|-------|-------|-------|-------|-------|-------|-------|-------|-------|-------|
| Bakersfield | C/L 1132 | 986 | 1178 | 1523 | 5007 | 5239 | 3620 | 2687 | 1189 | 1641 | 1514 | 1237 |
| San Jose | C/L 3577 | 3865 | 4073 | 3922 | 3735 | 3484 | 3648 | 5177 | 5245 | 4684 | 3636 | 3126 |
| Reno | C/L 2090 | 2278 | 2517 | 2177 | 1997 | 1797 | 2093 | 2262 | 2256 | 2006 | 1783 | 1757 |
| Klamath Falls | C/L 2780 | 2437 | 2768 | 2524 | 2289 | 2000 | 1898 | 2153 | 2297 | 2096 | 2168 | 2171 |
| | P/B 2 | 1 | 1 | 1 | 2 | 1 | 1 | 1 | 1 | 1 | 1 | 2 |
| Medford | C/L 3418 | 3722 | 3985 | 3765 | 3629 | 3653 | 3031 | 4013 | 3917 | 3365 | 3175 | 3564 |
| Eugene | C/L 17721 | 20186 | 20876 | 21352 | 19926 | 19980 | 19241 | 22857 | 21677 | 19573 | 17931 | 18161 |
| | P/G | | | | | | | | | | 4 | |
| Brooklyn | C/L 3678 | 3693 | 3835 | 3690 | 3628 | 3983 | 4215 | 4519 | 4131 | 4335 | 3385 | 3731 |
| | P/B | 396 | 399 | 345 | 385 | 331 | 979 | 877 | 752 | 1044 | 634 | 1043 |
| Mojave | C/L 1230 | 1188 | 1449 | 1275 | 1324 | 1346 | 1196 | 1293 | 1354 | 1431 | 1153 | 1301 |
| Quadalupe | C/L 970 | 1072 | 1619 | 1487 | 1347 | 1325 | 1010 | 1062 | 1542 | 905 | 1245 | 1343 |
| Oxnard | C/L 701 | 913 | 1063 | 1323 | 2117 | 2459 | 2261 | 2600 | 2545 | 2477 | 1121 | 884 |
| Los Angeles (Also P.E. Terminal)* | C/L 10801 | 9321 | 10760 | 9070 | 10147 | 9009 | 7302 | 7890 | 7262 | 8087 | 7061 | 7328 |
| | P/B | | | | | | | | | | | |
| | | | | | | 2336 | | | | | | |
| Long Beach (Also P.E. Terminal) | C/L 584 | 743 | 628 | 796 | 942 | 953 | 1006 | 903 | 919 | 748 | 787 | 834 |
| Los Angeles Harbor (Also P.E. Terminal) | C/L 384 | 240 | 248 | 247 | 350 | 380 | 335 | 379 | 250 | 202 | 97 | 216 |

*June 1961 Piggyback 2336 C/L included in dead freight.

PACIFIC LINES

| STATION | JAN | FEB | MAR | APR | MAY | JUNE | JULY | AUG | SEPT | OCT | NOV | DEC |
|-------------------------------------|-------|-------|-------|------|------|-------|------|-------|-------|------|------|------|
| Colton (Also C/L P. E. Terminal) | 4782 | 3774 | 4718 | 1538 | 3335 | 3440 | 4417 | 3398 | 2176 | 2477 | 2394 | 2587 |
| Indio C/L | 141 | 95 | 150 | 103 | 139 | 768 | 216 | 858 | 428 | 77 | 600 | 823 |
| El Centro C/L | 2956 | 4059 | 1724 | 1217 | 3084 | 3345 | 1564 | 588 | 297 | 306 | 338 | 1575 |
| (Also S. D. & A. E. Terminal) | | | | | | | | | | | | |
| Yuma C/L | 937 | 909 | 1583 | 346 | 622 | 4373 | 117 | 76 | 318 | 347 | 642 | 1505 |
| Phoenix C/L | 11606 | 11252 | 11073 | 8447 | 8419 | 10090 | 5467 | 8349 | 7577 | 8617 | 9465 | 8880 |
| Tucson C/L | 1529 | 1561 | 1466 | 1210 | 1244 | 1156 | 770 | 713 | 719 | 1107 | 1447 | 1371 |
| Douglas C/L | 315 | 895 | 1586 | 1675 | 1523 | 1302 | 707 | 1481 | 1348 | 1463 | 1504 | 1570 |
| Tucumcari C/L | 47 | 38 | 43 | 56 | 53 | 28 | 41 | 37 | 64 | 230 | 92 | 30 |
| Ogden C/L | 414 | 291 | 370 | 514 | 381 | 277 | 285 | 326 | 417 | 386 | 426 | 297 |
| Watsonville C/L Jct. | 3102 | 2609 | 3637 | 3768 | 7393 | 8513 | 8878 | 10809 | 11289 | 9767 | 7640 | 5301 |
| El Paso C/L | 923 | 1112 | 1725 | 1755 | 2881 | 2166 | 1347 | 1486 | 1674 | 1953 | 2402 | 1796 |

TEXAS and LOUISIANA LINES

| STATION | JAN | FEB | MAR | APR | MAY | JUNE | JULY | AUG | SEPT | OCT | NOV | DEC |
|---------------------|------|------|------|------|------|------|------|------|------|------|------|------|
| Schriever C/L | 511 | 715 | 679 | 694 | 1205 | 1152 | 1011 | 491 | 570 | 649 | 1157 | 978 |
| New Ibernia C/L | 601 | 612 | 718 | 596 | 580 | 573 | 586 | 557 | 741 | 704 | 969 | 850 |
| Lafayette C/L | 1258 | 1556 | 1715 | 1537 | 1546 | 1536 | 1424 | 1408 | 1723 | 1892 | 1971 | 2099 |
| | P/B | | | | 5 | | | | | | | |
| Beaumont C/L | 34 | 39 | 36 | 33 | 44 | 29 | 59 | 56 | 44 | 61 | 65 | 72 |
| Avondale C/L | 2255 | 2817 | 3025 | 3317 | 3038 | 3317 | 2846 | 3176 | 2692 | 2269 | 2507 | 2564 |
| | P/B | | | | 52 | | | | | | | |
| Lake Charles C/L | 1888 | 1758 | 2034 | 1539 | 1507 | 1459 | 1447 | 1481 | 2048 | 2045 | 1737 | 1824 |
| | P/B | | | | 4 | | | | | | | |
| Houston C/L | 6734 | 6848 | 9078 | 7780 | 6938 | 7266 | 6772 | 7434 | 8070 | 7454 | 6199 | 6383 |
| | P/B | | | | 155 | | | | | | | |
| Beaumont C/L | 3068 | 2595 | 2673 | 3013 | 3112 | 2830 | 2572 | 3416 | 3588 | 2780 | 2514 | 2757 |
| Lufkin C/L | 620 | 601 | 987 | 629 | 685 | 733 | 677 | 651 | 668 | 621 | 577 | 448 |
| Shreveport C/L | 751 | 827 | 937 | 738 | 752 | 686 | 562 | 798 | 701 | 706 | 600 | 631 |
| | P/B | | | | 11 | | | | | | | |
| Edinburg C/L | 1753 | 1648 | 1882 | 1240 | 944 | 754 | 747 | 1147 | 691 | 467 | 530 | 686 |
| Eagle Lake C/L | 2243 | 2423 | 3773 | 3844 | 3782 | 4292 | 4188 | 3846 | 4807 | 3772 | 3785 | 2467 |
| Eagle Pass C/L | 1 | 1 | 98 | 147 | 13 | 49 | 355 | 45 | 42 | 25 | 40 | 2 |
| Glidden C/L | 827 | 921 | 1523 | 1496 | 1529 | 1237 | 1253 | 1274 | 1505 | 1408 | 1209 | 1189 |

TEXAS and LOUISIANA LINES

| STATION | JAN | FEB | MAR | APR | MAY | JUNE | JULY | AUG | SEPT | OCT | NOV | DEC |
|----------------|----------|------|------|------|------|------|------|------|------|------|------|------|
| Miller | C/L 748 | 776 | 862 | 784 | 850 | 876 | 671 | 747 | 842 | 799 | 859 | 746 |
| | P/B | | | | 66 | | | | | | | |
| Fort Worth | C/L 742 | 720 | 865 | 515 | 522 | 642 | 645 | 632 | 794 | 571 | 548 | 743 |
| Victoria | C/L 579 | 623 | 851 | 1006 | 847 | 1059 | 1073 | 915 | 985 | 743 | 693 | 820 |
| San Antonio | C/L 1786 | 1760 | 2423 | 2779 | 2675 | 2577 | 1949 | 2188 | 1917 | 1760 | 1535 | 1499 |
| | P/B | | | | 52 | | | | | | | |
| Corpus Christi | C/L 1206 | 1130 | 1615 | 1262 | 1467 | 1508 | 1565 | 1246 | 1375 | 1499 | 1125 | 877 |
| | P/B | | | | 4 | | | | | | | |
| El Paso | C/L 1008 | 767 | 952 | 1127 | 1133 | 939 | 562 | 694 | 696 | 593 | 603 | 624 |
| Hearne | C/L 578 | 270 | 324 | 331 | 327 | 435 | 384 | 574 | 383 | 627 | 623 | 394 |
| | P/B | | | | 7 | | | | | | | |
| Corsicana | C/L 54 | 51 | 34 | 32 | 41 | 72 | 43 | 82 | 56 | 54 | 57 | 57 |
| Ennis | C/L 319 | 333 | 272 | 263 | 266 | 410 | 262 | 412 | 429 | 561 | 492 | 300 |
| Austin | C/L 401 | 645 | 762 | 849 | 845 | 966 | 720 | 1015 | 827 | 767 | 590 | 463 |
| | P/B | | | | 3 | | | | | | | |

NORTHWESTERN PACIFIC, PACIFIC ELECTRIC, and S. D. & A. E.

| STATION | JAN | FEB | MAR | APR | MAY | JUNE | JULY | AUG | SEPT | OCT | NOV | DEC |
|-------------------------------|------|------|------|------|------|------|------|------|------|------|------|------|
| Schellville (N. W. P.) | 770 | 791 | 977 | 1071 | 965 | 1084 | 877 | 1117 | 1306 | 1088 | 847 | 753 |
| Long Beach (P. E.) | 573 | 656 | 689 | 799 | 806 | 708 | 614 | 551 | 582 | 483 | 593 | 513 |
| Los Angeles Harbor (P. E.) | 303 | 1026 | 1106 | 923 | 1041 | 852 | 857 | 1132 | 1175 | 982 | 1199 | 880 |
| Colton (P. E.) | 317 | 370 | 470 | 391 | 386 | 353 | 307 | 335 | 327 | 142 | 126 | 192 |
| El Centro (S. D. & A. E.) | 2307 | 2432 | 2100 | 1754 | 2584 | 2723 | 1376 | 1229 | 1137 | 1058 | 1036 | 1558 |
| Eureka (N. W. P.) | 3153 | 3218 | 3845 | 3590 | 3657 | 4241 | 3202 | 3927 | 3400 | 3117 | 2694 | 2157 |
| Santa Rosa (N. W. P.) | 770 | 791 | 977 | 1071 | 965 | 1084 | 877 | 1117 | 1306 | 1088 | 847 | 753 |
| Los Angeles (P. E.) | 2241 | 2548 | 3360 | 2738 | 3091 | 3050 | 2537 | 2841 | 2524 | 2681 | 2546 | 2741 |
| Los Nietos (P. E.) | 1499 | 1582 | 1820 | 1744 | 2299 | 2197 | 1756 | 1773 | 1739 | 1481 | 1350 | 1620 |

INTERCHANGE STATISTICS

This section contains interchange statistics for each division of the Pacific Lines (for June, 1960) and the Texas and Louisiana Lines (for January, 1961).

June, 1960
Freight Cars Interchanged
Portland Division

| STATION | <u>Delivered</u> | | | <u>Received</u> | | | <u>I/O Unit Assignments</u> | | |
|---------------|------------------|--------------|--|-----------------|--------------|--|-----------------------------|-------------------|---------|
| | LOADS | EMPTYES | | LOADS | EMPTYES | | MINOR | MAJORS I/O | PERCENT |
| Eugene | 394 | 200 | | 300 | 323 | | | Old Yard Eugene | 100% |
| Albany | 137 | 67 | | 100 | 128 | | | Albany | 100% |
| Salem | 71 | 124 | | 161 | 47 | | | Salem | 100% |
| Oregon City | 1 | 0 | | 0 | 0 | | | Brooklyn | 100% |
| Brooklyn | 3,136 | 932 | | 2,555 | 2,293 | | | Brooklyn | 100% |
| East Portland | 729 | 471 | | 735 | 594 | | | Brooklyn | 100% |
| Portland (NP) | 4,325 | 956 | | 2,470 | 2,314 | | | NPT - Interchange | 100% |
| Portland * | 2,842 | 1,504 | | 3,106 | 1,672 | | | Brooklyn | 100% |
| Lebanon | 80 | 176 | | 212 | 73 | | Lebanon | Eugene | 100% |
| TOTAL | 11,715 | 4,430 | | 9,639 | 7,444 | | | | |

* Does not include NP.

June, 1960
Freight Cars Interchanged
Shasta Division

| STATION | <u>Delivered</u> | | <u>Received</u> | | <u>I/O Unit Assignments</u> | | |
|---------------|------------------|---------|-----------------|---------|-----------------------------|-------------------------|------------|
| | LOADS | EMPTYES | LOADS | EMPTYES | MINOR | MAJOR | PERCENT |
| Klamath Falls | 53 | 398 | 54 | 139 | | Klamath Falls | 100% |
| Lobert | 0 | 9 | 0 | 9 | | Klamath Falls Eugene | 90% 10% |
| Chemult | 197 | 65 | 396 | 62 | Chemult | Klamath Falls Eugene | 90% 10% |
| TOTAL | 250 | 472 | 450 | 210 | | | |

June, 1960
 Freight Cars Interchanged
 Salt Lake Division

| STATION | Delivered | | Received | | I/O Unit Assignments | | | PERCENT |
|---------|-----------|---------|----------|---------|----------------------|-----------------|------------|---------|
| | LOADS | EMPTYES | LOADS | EMPTYES | MINOR | MAJOR | | |
| Reno | 63 | 38 | 80 | 17 | | Sparks | 100% | |
| Elko | 0 | 0 | 1 | 1 | | Carlin Ogden | 50% 50% | |
| Wells | 142 | 5 | 90 | 732 | Wells | Carlin Ogden | 50% 50% | |
| Cobre | 131 | 35 | 33 | 147 | | Carlin Ogden | 50% 50% | |
| Ogden | 29,455 | 4,807 | 11,964 | 17,173 | | Ogden | 100% | |
| TOTAL | 29,791 | 4,885 | 12,168 | 18,070 | | | | |

June, 1960
 Freight Cars Interchanged
 Coast Division

| STATION | <u>Delivered</u> | | <u>Received</u> | | <u>I/O Unit Assignments</u> | | PERCENT |
|---------------|------------------|----------|-----------------|----------|-----------------------------|-------------|---------|
| | LOADS | EMPTYIES | LOADS | EMPTYIES | MINOR | MAJOR | |
| San Francisco | 808 | 996 | 1,560 | 596 | | Mission Bay | 100% |
| San Jose | 446 | 104 | 207 | 244 | | San Jose | 100% |
| TOTAL | 1,254 | 1,110 | 1,767 | 840 | | | |

Southern Pacific Company

June, 1960
Freight Cars Interchanged
Western Division

| <u>Interchange Point</u> | <u>Delivered</u> | | <u>Received</u> | | <u>I/O Unit Assignments</u> | | |
|--------------------------|------------------|----------|-----------------|----------|-----------------------------|--|--------------------------|
| | LOADS | EMPTYIES | LOADS | EMPTYIES | MINOR | MAJOR | PERCENT |
| WESTERN DIVISION | | | | | | | |
| Schellville | 442 | 4,509 | 4,842 | 345 | | Schellville | 100% |
| Richmond | 551 | 187 | 208 | 631 | | Richmond Transfer | 100% |
| Oakland (ATSF, OKT) | 330 | 679 | 691 | 297 | | Desert, Oakland | 100% |
| Oakland (HOWT, WP) | 864 | 637 | 669 | 921 | | Homestead, Oakland | 100% |
| Niles | 0 | 6 | 0 | 7 | | Niles | 100% |
| Stockton | 2,490 | 2,229 | 2,222 | 1,378 | | Stockton | 100% |
| Lodi | 55 | 45 | 19 | 23 | | Lodi | 100% |
| Port Chicago | 2 | 84 | 144 | 38 | | Port Chicago | 100% |
| McAvoy | 49 | 0 | 2 | 47 | | Port Chicago | 100% |
| Pittsburg | 5 | 98 | 9 | 238 | Pittsburg | Tracy Oakland Yard Office | 70% 30% |
| Lyothe | 0 | 14 | 0 | 2 | | Tracy Fresno | 90% 10% |
| Modesto | 71 | 76 | 69 | 45 | | Modesto | 100% |
| Turlock | 55 | 0 | 17 | 30 | Turlock | Roseville Stockton Tracy Fresno | 70% 10% 10% 10% |

June, 1960
 Freight Cars Interchanged
 Western Division
 (continued)

| <u>Interchange Point</u> | <u>Delivered</u> | | <u>Received</u> | | <u>I/O Unit Assignments</u> | | |
|--------------------------|------------------|----------|-----------------|----------|-----------------------------|--|-------------------|
| | LOADS | EMPTYIES | LOADS | EMPTYIES | MINOR | MAJOR | PERCENT |
| WESTERN DIVISION | | | | | | | |
| Milpitas | 2 | 73 | 1 | 17 | Milpitas | Tracy San Jose Oakland Yard Office | 40% 30% 30% |
| Lombard | 0 | 0 | 0 | 1 | | Lombard - NAPA Jct. | 100% |
| Las Juntas | 1 | 0 | 0 | 0 | | Port Chicago | 100% |
| Alameda | 436 | 470 | 718 | 413 | | Homestead, Oakland | 100% |
| TOTAL | 5,604 | 9,107 | 9,611 | 4,434 | | | |

June, 1960
 Freight Cars Interchanged
 Sacramento Division

| STATION | <u>Delivered</u> | | <u>Received</u> | | <u>I/O Unit Assignments</u> | | | PERCENT |
|--------------|------------------|------------|-----------------|------------|-----------------------------|---------------------|--|------------|
| | LOADS | EMPTY | LOADS | EMPTY | MINOR | MAJOR | | |
| Sacramento | 442 | 381 | 470 | 240 | | Sacramento | | 100% |
| Polk | 91 | 75 | 149 | 49 | | Sacramento | | 100% |
| Marysville | 109 | 91 | 220 | 49 | Marysville | Roseville Gerber | | 90% 10% |
| Chico | 27 | 10 | 27 | 22 | | Roseville Gerber | | 90% 10% |
| Oroville | 17 | 17 | 25 | 14 | Marysville | Roseville | | 100% |
| TOTAL | 686 | 574 | 891 | 374 | | | | |

June, 1960
Freight Cars Interchanged
San Joaquin Division

| STATION | Delivered | | Received | | I/O Unit Assignments | | | PERCENT |
|-------------|-----------|----------|----------|----------|----------------------|-----------------------|------------|---------|
| | LOADS | EMPTYIES | LOADS | EMPTYIES | MINOR | MAJOR | | |
| Fresno | 477 | 210 | 266 | 344 | | Fresno | 100% | |
| Bakersfield | 622 | 856 | 1,013 | 508 | | Bakersfield | 100% | |
| Famoso | 1 | 102 | 0 | 48 | Famoso | Fresno Bakersfield | 70% 30% | |
| Slater | 0 | 66 | 0 | 130 | Famoso | Fresno Bakersfield | 70% 30% | |
| Cawelo | 0 | 178 | 0 | 23 | Famoso | Fresno Bakersfield | 70% 30% | |
| Lerdo | 0 | 0 | 0 | 66 | | Fresno Bakersfield | 70% 30% | |
| Saco | 0 | 266 | 0 | 147 | | Fresno Bakersfield | 70% 30% | |
| Edison | 0 | 330 | 0 | 3 | | Bakersfield | 100% | |
| Richgrove | 0 | 23 | 0 | 14 | Jovista | Fresno Bakersfield | 70% 30% | |
| Jasmin | 0 | 20 | 0 | 0 | | Fresno Bakersfield | 70% 30% | |
| Hollis | 0 | 23 | 0 | 0 | | Fresno Bakersfield | 70% 30% | |

June, 1960
 Freight Cars Interchanged
 San Joaquin Division
 (continued)

| STATION | <u>Delivered</u> | | <u>Received</u> | | <u>I/O Unit Assignments</u> | | |
|--------------|------------------|----------|-----------------|----------|-----------------------------|-----------------------|------------|
| | LOADS | EMPTYIES | LOADS | EMPTYIES | MINOR | MAJOR | PERCENT |
| Jovista | 0 | 0 | 0 | 14 | Jovista | Fresno Bakersfield | 70% 30% |
| Lamont | 0 | 127 | 0 | 1 | | Bakersfield | 100% |
| Ribier | 0 | 19 | 0 | 0 | | Bakersfield | 100% |
| Di Giorgio | 0 | 75 | 0 | 4 | | Bakersfield | 100% |
| Arvin | 0 | 836 | 0 | 1 | | Bakersfield | 100% |
| Algozo | 0 | 14 | 0 | 0 | | Bakersfield | 100% |
| Harpertown | 0 | 4 | 0 | 5 | | Bakersfield | 100% |
| Patch | 0 | 53 | 0 | 0 | | Bakersfield | 100% |
| Magunden | 0 | 1 | 0 | 0 | | Bakersfield | 100% |
| Oil Junction | 0 | 0 | 0 | 2 | | Fresno Bakersfield | 70% 30% |
| Mojave | 7 | 16 | 14 | 4 | | Mojave | 100% |
| Visalia | 41 | 19 | 31 | 25 | | Fresno Bakersfield | 90% 10% |
| TOTAL | 1,148 | 3,238 | 1,324 | 1,339 | | | |

June, 1960
Freight Cars Interchanged
Los Angeles Division

| STATION | Delivered | | Received | | I/O Unit Assignments | | PERCENT |
|------------------------------|-----------|---------|----------|---------|----------------------|-----------------------------|---------|
| | LOADS | EMPTYES | LOADS | EMPTYES | MINOR | MAJOR | |
| San Fernando | 0 | 0 | 38 | 17 | | Taylor Hump | 100% |
| San Fernando | 13 | 38 | 0 | 0 | | Taylor "C" | 100% |
| Los Angeles (ATSF) | 2,444 | 1,089 | 1,680 | 2,035 | | ATSF - Interchange | 100% |
| Los Angeles (UP) | 2,176 | 1,300 | 1,404 | 1,603 | | UP - Interchange | 100% |
| Los Angeles (LAJRR) | 1,348 | 282 | 751 | 1,221 | | L. A. Jct. RR - Interchange | 100% |
| Los Angeles * | 1,740 | 1,073 | 1,152 | 927 | | Bullring | 100% |
| Long Beach | 656 | 227 | 181 | 620 | | Long Beach | 100% |
| Carson (or Elftman) | 230 | 200 | 0 | 0 | Dolores | Taylor "C" | 100% |
| Carson (or Elftman) | 0 | 0 | 439 | 916 | Dolores | Bullring, Taylor Yard | 100% |
| Wilmington (or L. A. Harbor) | 464 | 172 | 115 | 461 | | L. A. Harbor | 100% |
| Bassett | 0 | 249 | 119 | 0 | | City of Industry | 100% |
| Kaiser | 0 | 42 | 0 | 19 | | Kaiser | 100% |
| Colton | 1,149 | 1,432 | 1,450 | 964 | | Colton | 100% |
| Anaheim | 13 | 37 | 34 | 3 | Anaheim | Los Nietos | 100% |
| Santa Ana | 7 | 27 | 61 | 65 | Santa Ana | Los Nietos | 100% |

*Does not include ATSF, UP or LAJRR Interchanges.

June, 1960
 Freight Cars Interchanged
 Los Angeles Division
 (continued)

| STATION | <u>Delivered</u> | | <u>Received</u> | | <u>I/O Unit Assignments</u> | | |
|------------|------------------|---------|-----------------|---------|-----------------------------|------------|---------|
| | LOADS | EMPTYES | LOADS | EMPTYES | MINOR | MAJOR | PERCENT |
| Los Nietos | 1,884 | 490 | 1,686 | 980 | | Los Nietos | 100% |
| El Centro | 677 | 1,161 | 1,633 | 604 | | El Centro | 100% |
| Riverside | 54 | 5 | 16 | 36 | | Colton | 100% |
| Mexicali | 157 | 199 | 201 | 31 | | El Centro | 100% |
| TOTAL | 13,012 | 8,023 | 10,960 | 10,502 | | | |

June, 1960
 Freight Cars Interchanged
 Tucson Division

| STATION | <u>Delivered</u> | | <u>Received</u> | | <u>I/O Unit Assignments</u> | | PERCENT |
|---------|------------------|----------|-----------------|----------|-----------------------------|------------------|---------|
| | LOADS | EMPTYIES | LOADS | EMPTYIES | MINOR | MAJOR | |
| Phoenix | 654 | 624 | 638 | 567 | | Phoenix | 100% |
| Nogales | 364 | 271 | 690 | 303 | Nogales | 22nd St., Tucson | 100% |
| TOTAL | 1,018 | 895 | 1,328 | 870 | | | |

Southern Pacific Company

June, 1960
Freight Cars Interchanged
Rio Grande Division

| STATION | Delivered | | Received | | I/O Unit Assignments | | |
|-----------|-----------|----------|----------|----------|----------------------|---|-------------------|
| | LOADS | EMPTYIES | LOADS | EMPTYIES | MINOR | MAJOR | PERCENT |
| Deming | 307 | 170 | 597 | 32 | | Deming | 100% |
| Vaughn | 17 | 22 | 10 | 305 | Vaughn | Tucumari Dallas St., El Paso Adair, El Paso | 60% 20% 20% |
| Tucumcari | 9,790 | 1,895 | 3,665 | 8,824 | | Tucumcari | 100% |
| Naco | 44 | 4 | 5 | 22 | Bisbee Jct. | Douglas | 100% |
| Douglas | 20 | 2 | 1 | 28 | | Douglas | 100% |
| French | 0 | 14 | 0 | 53 | | Tucumcari | 100% |
| El Paso * | 12,886 | 4,757 | 11,534 | 7,284 | | Dallas St., El Paso Adair, El Paso | 95% 5% |
| TOTAL | 23,064 | 6,864 | 15,812 | 16,548 | | | |

* Includes Texas and New Orleans volumes which were not assigned.

January, 1961
 Freight Cars Interchanged
 San Antonio Division

| Interchange Point STATION | Delivered | | Received | | I/O Unit Assignments | | PERCENT |
|------------------------------|-----------|----------|----------|----------|----------------------|---|--------------------------|
| | LOADS | EMPTYIES | LOADS | EMPTYIES | MINOR | MAJOR | |
| Alpine | 10 | 4 | 22 | 7 | | Valentine Del Rio | 20% 80% |
| Alice | 989 | 125 | 230 | 622 | | Alice | 100% |
| Brownsville | 54 | 84 | 66 | 113 | | Brownsville | 100% |
| Corpus Christi | 551 | 312 | 326 | 596 | | Corpus Christi | 100% |
| Eagle Pass | 275 | 319 | 251 | 385 | | Eagle Pass | 100% |
| Edinburg | 32 | 2 | 1 | 36 | | Edinburg | 100% |
| El Paso | 7,837 | 4,042 | 7,391 | 3,288 | | El Paso | 100% |
| Harlingen | 27 | 32 | 41 | 79 | Harlingen | Edinburg | 100% |
| Mathis | 2 | 11 | 4 | 2 | | San Antonio Gregory Victoria | 60% 20% 20% |
| McAllen | 32 | 2 | 3 | 18 | McAllen | Edinburg | 100% |
| San Antonio | 583 | 561 | 887 | 357 | | San Antonio | 100% |
| Sierra Blanca | 25 | 0 | 23 | 0 | | Valentine El Paso | 80% 20% |
| Sinto | 39 | 6 | 7 | 2 | | Gregory Victoria San Antonio Alice | 25% 25% 25% 25% |
| Uvalde | 2 | 17 | 59 | 2 | Uvalde | San Antonio Del Rio | 80% 20% |

January, 1961
Freight Cars Interchanged
Houston Division

| Interchange Point STATION | Delivered | | | Received | | | I/O Unit Assignments | | | PERCENT |
|---|-----------|----------|-------|----------|-------|----------|----------------------|-----------------------|------------|---------|
| | LOADS | EMPTYIES | LOADS | EMPTYIES | LOADS | EMPTYIES | MINOR | MAJOR | | |
| Bay City | 8 | 26 | 21 | 19 | | | Wharton | Englewood Victoria | 80% 20% | |
| Cleveland | 26 | 18 | 170 | 11 | | | | Englewood Lufkin | 70% 30% | |
| Diboll | 91 | 151 | 45 | 32 | | | | Lufkin Englewood | 30% 70% | |
| Eagle Lake | 519 | 86 | 6 | 530 | | | | Eagle Lake | 100% | |
| Galveston | 202 | 1,005 | 1,103 | 371 | | | | Galveston | 100% | |
| Houston (MKT, PTR A) | 1,037 | 923 | 1,165 | 959 | | | | West End | 100% | |
| Houston via PTR A (MKT) | 0 | 118 | 17 | 101 | | | | West End | 100% | |
| Houston (FWD, GCSF, HBT, MP, RI) | 2,772 | 2,050 | 2,336 | 2,308 | | | | Englewood | 100% | |
| Houston via PTR A (FWD, GCSF, HBT, MP, RI) | 0 | 664 | 154 | 1,016 | | | | Englewood | 100% | |
| Long Point | 0 | 5 | 0 | 0 | | | | Englewood | 100% | |
| Lufkin | 52 | 209 | 338 | 104 | | | | Lufkin | 100% | |
| Lufkin via ANR | 208 | 0 | 8 | 14 | | | | Lufkin | 100% | |
| New Gulf | 0 | 13 | 0 | 18 | | | New Gulf | Englewood Victoria | 80% 20% | |

January, 1961
 Freight Car Interchanged
 Houston Division
 (Continued)

| Interchange Point STATION | Delivered | | Received | | I/O Unit Assignments | | | PERCENT |
|------------------------------|-----------|----------|----------|----------|----------------------|--------------------------------------|--|-------------------|
| | LOADS | EMPTYIES | LOADS | EMPTYIES | MINOR | MAJOR | | |
| Rosenburg | 56 | 38 | 23 | 21 | | Englewood Victoria San Antonio | | 70% 15% 15% |
| Shreveport | 3,269 | 1,849 | 3,136 | 3,061 | | Shreveport | | 100% |
| Sugarland | 125 | 4 | 81 | 107 | | Englewood Victoria San Antonio | | 70% 15% 15% |
| Tenaha | 169 | 346 | 375 | 122 | | Shreveport Lufkin Dallas | | 50% 25% 25% |
| Texas City | 4 | 142 | 141 | 134 | | Englewood | | 100% |
| Texas City via Sea Train | 152 | 38 | 0 | 0 | | Englewood | | 100% |
| Victoria | 109 | 35 | 19 | 112 | | Victoria | | 100% |
| Wharton | 21 | 66 | 5 | 13 | Wharton | Englewood Victoria | | 80% 20% |

January, 1961
 Freight Cars Interchanged
 Dallas-Austin Division

| Interchange Point STATION | Delivered | | | Received | | | I/O Unit Assignments | | |
|------------------------------|-----------|---------|--|----------|---------|--|----------------------|--|--------------------------|
| | LOADS | EMPTYES | | LOADS | EMPTYES | | MINOR | MAJOR | PERCENT |
| Athens | 6 | 16 | | 22 | 5 | | | Lufkin Dallas Shreveport | 35% 35% 30% |
| Austin | 87 | 53 | | 110 | 56 | | | Austin | 100% |
| Brenham | 34 | 15 | | 28 | 9 | | Brenham | San Antonio Englewood Hearne Austin | 20% 30% 20% 30% |
| Bryan | 13 | 0 | | 2 | 12 | | | Englewood Hearne | 50% 50% |
| Caldwell | 52 | 20 | | 62 | 33 | | | Austin Hearne San Antonio | 35% 35% 30% |
| Cameron | 13 | 17 | | 5 | 6 | | | Waco | 100% |
| Commevle | 14 | 54 | | 49 | 19 | | | Dallas | 100% |
| Corsicana | 4,402 | 2,976 | | 5,364 | 700 | | | Corsicana | 100% |
| Dallas | 943 | 1,478 | | 1,746 | 882 | | | Dallas | 100% |
| Denison | 828 | 605 | | 885 | 489 | | | Denison | 100% |
| Elgin | 3 | 0 | | 6 | 0 | | | San Antonio Houston Hearne Austin | 20% 30% 20% 30% |

January, 1961
 Freight Cars Interchanged
 Dallas-Austin Division
 (Continued)

| Interchange Point STATION | Delivered | | Received | | I/O Unit Assignments | | | PERCENT |
|------------------------------|-----------|---------|----------|---------|----------------------|--------------------------------|-------------------|---------|
| | LOADS | EMPTYES | LOADS | EMPTYES | MINOR | MAJOR | | |
| Fort Worth | 2,055 | 1,722 | 2,944 | 1,400 | | Fort Worth | 100% | |
| Hearne | 2 | 128 | 24 | 110 | | Hearne | 100% | |
| Jacksonville | 76 | 67 | 60 | 71 | Jacksonville | Lufkin Dallas Shreveport | 35% 35% 30% | |
| McNeil | 35 | 4 | 5 | 21 | | Austin | 100% | |
| Mexia | 9 | 0 | 2 | 9 | | Ennis Hearne | 30% 70% | |
| Midlothian | 3 | 0 | 0 | 0 | | Fort Worth | 100% | |
| Navasota | 54 | 17 | 13 | 13 | | Englewood Hearne | 50% 50% | |
| Palestine | 1 | 0 | 1 | 0 | Jacksonville | Lufkin Dallas Shreveport | 35% 35% 30% | |
| Paris | 28 | 4 | 8 | 14 | | Dallas | 100% | |
| Plano | 0 | 5 | 14 | 1 | | Ennis | 100% | |
| Rusk | 25 | 0 | 1 | 5 | Jacksonville | Lufkin Dallas Shreveport | 35% 35% 30% | |
| Sherman | 683 | 526 | 1,296 | 366 | | Sherman | 100% | |

January, 1961
 Freight Cars Interchanged
 Dallas-Austin Division
 (Continued)

| Interchange Point | Delivered | | Received | | I/O Unit Assignments | | | PERCENT |
|-------------------|-----------|----------|----------|----------|----------------------|------------------------------------|--|-------------------|
| | LOADS | EMPTYIES | LOADS | EMPTYIES | MINOR | MAJOR | | |
| Waco | 129 | 218 | 286 | 181 | | Waco | | 100% |
| Waxahachie | 3 | 0 | 4 | 2 | | Ennis | | 100% |
| West Point | 0 | 0 | 4 | 0 | | San Antonio Englewood Hearne | | 35% 35% 30% |

January, 1961
Freight Cars Interchanged
Lafayette Division

| Interchange Point STATION | Delivered | | Received | | I/O Unit Assignments | | | PERCENT |
|------------------------------|-----------|----------|----------|----------|----------------------|---|-------------------|---------|
| | LOADS | EMPTYIES | LOADS | EMPTYIES | MINOR | MAJOR | | |
| Alexandria | 788 | 433 | 867 | 510 | | Alexandria | 100% | |
| Avondale | 194 | 300 | 260 | 236 | | Avondale | 100% | |
| Baytown | 147 | 197 | 135 | 173 | Baytown | Englewood Beaumont | 60% 40% | |
| Beaumont | 1,223 | 1,239 | 1,305 | 1,527 | | Beaumont | 100% | |
| Boutte | 0 | 35 | 0 | 60 | | Avondale | 100% | |
| Chaison | 95 | 279 | 305 | 71 | | Beaumont | 100% | |
| Cheneyville | 1 | 0 | 0 | 1 | | Lafayette | 100% | |
| Crowley | 23 | 18 | 14 | 5 | | Lake Charles Lafayette | 50% 50% | |
| De Ridder | 57 | 32 | 30 | 39 | | Lake Charles | 100% | |
| Eunice | 29 | 253 | 50 | 68 | Eunice | New Iberia Lake Charles Lafayette | 35% 35% 30% | |
| Franklin via Garden City | 0 | 0 | 1 | 0 | | Avondale New Iberia | 60% 40% | |
| Garden City | 0 | 1 | 0 | 2 | | Avondale New Iberia | 60% 40% | |
| Harvey | 0 | 285 | 0 | 182 | | Avondale | 100% | |

January, 1961
 Freight Cars Interchanged
 Lafayette Division
 (Continued)

| Interchange Point STATION | Delivered | | Received | | I/O Unit Assignments | | | PERCENT |
|------------------------------|-----------|---------|----------|---------|----------------------|------------------------|------------|---------|
| | LOADS | EMPTYES | LOCALS | EMPTYES | MINOR | MAJOR | | |
| Jeanerette | 0 | 0 | 0 | 7 | | Avondale New Iberia | 60% 40% | |
| Kountze | 31 | 3 | 29 | 3 | | Beaumont | 100% | |
| Lake Charles | 451 | 549 | 502 | 566 | | Lake Charles | 100% | |
| McDonoghville | 121 | 24 | 48 | 19 | | Avondale | 100% | |
| New Iberia | 6 | 76 | 7 | 7 | | New Iberia | 100% | |
| New Orleans | 6,859 | 1,918 | 2,866 | 4,941 | | Avondale | 100% | |
| Opelonsas | 58 | 34 | 28 | 60 | | Lafayette | 100% | |
| Orange | 70 | 48 | 40 | 67 | | Beaumont | 100% | |
| Port Arthur | 269 | 789 | 460 | 338 | | Beaumont | 100% | |
| Shrewsbury | 1,299 | 974 | 1,127 | 1,076 | | Avondale | 100% | |

CARLOADING STATISTICS

This section is comprised of three graphs. The first shows the yearly carloading for the period from 1952 to 1960 for the Pacific Lines, Texas and Louisiana Lines, Pacific Electric Railway and the Northwestern Pacific Railroad. The second graph presents carload shipments by class for the Pacific Lines for the period from 1957 to 1960. The third graph is the same as the second but is for the Texas and Louisiana Lines.

YEARLY CARLOADING FOR THE PACIFIC LINES, TEXAS AND LOUISIANA LINES, PACIFIC ELECTRIC RAILWAY, AND NORTHWESTERN PACIFIC R.R.

1952-1960

YEARLY CARLOADINGS, AVERAGE = 3,059,090 CARS
 MONTHLY CARLOADINGS, AVERAGE = 254,924 CARS
 DAILY CARLOADINGS, AVERAGE = 8,381 CARS

VARIATION OF CARLOADINGS FOR THE PAST 9 YEARS = ±7.4% OF AVERAGE. (REFERENCE: CS-9805-A)

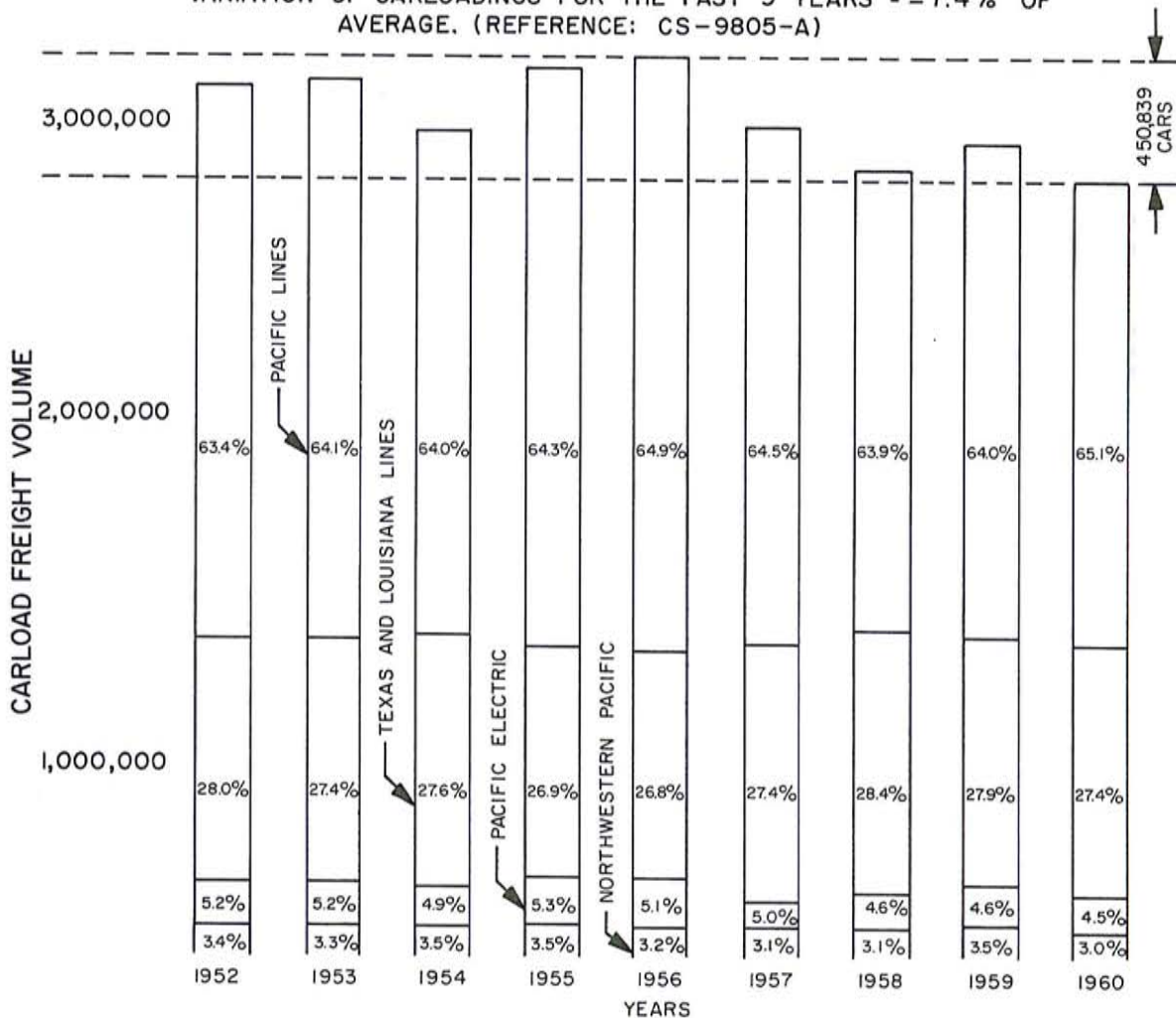

SOUTHERN PACIFIC COMPANY (Pacific Lines)
 CARLOAD SHIPMENTS BY CLASS (1957-1960)

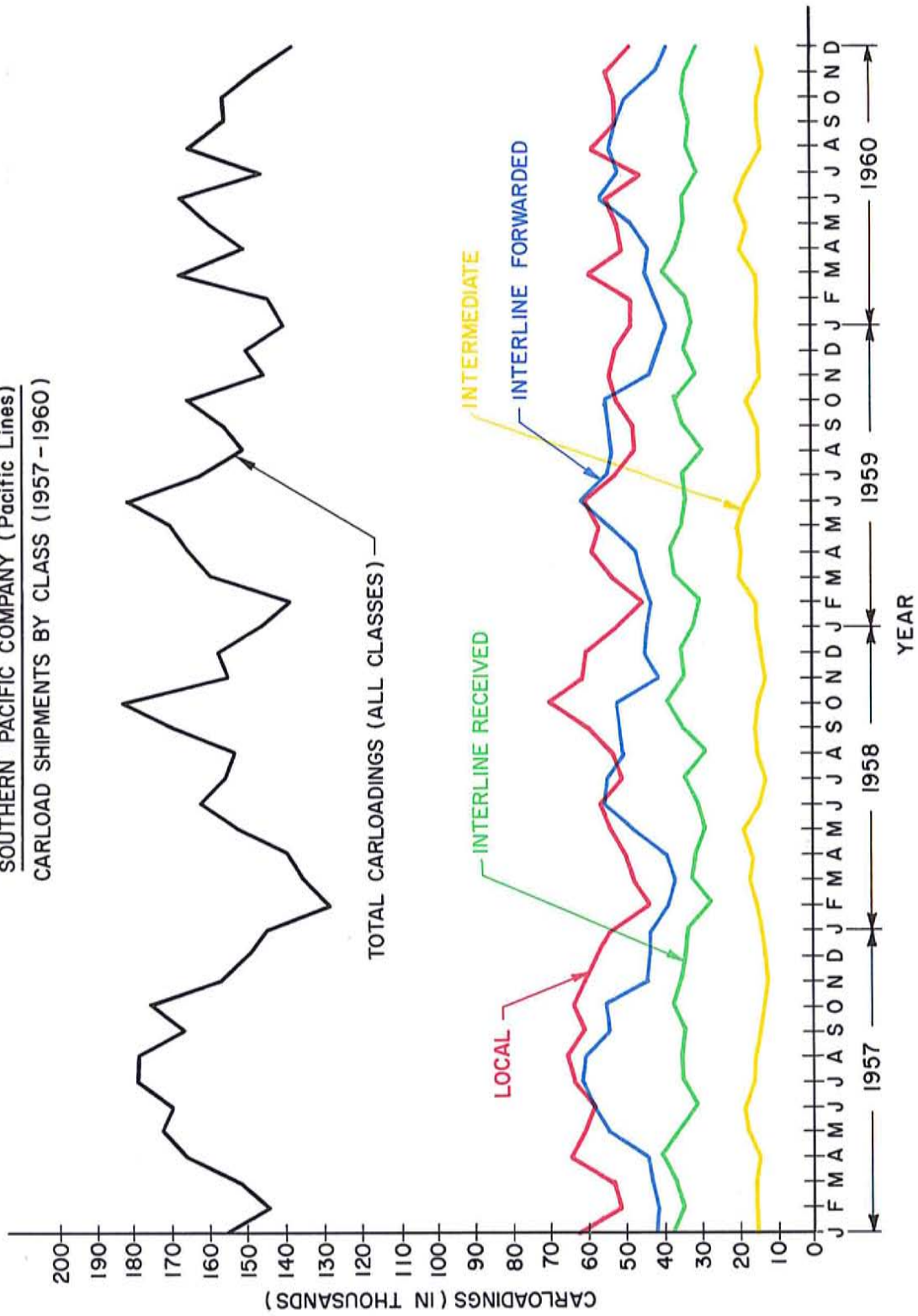

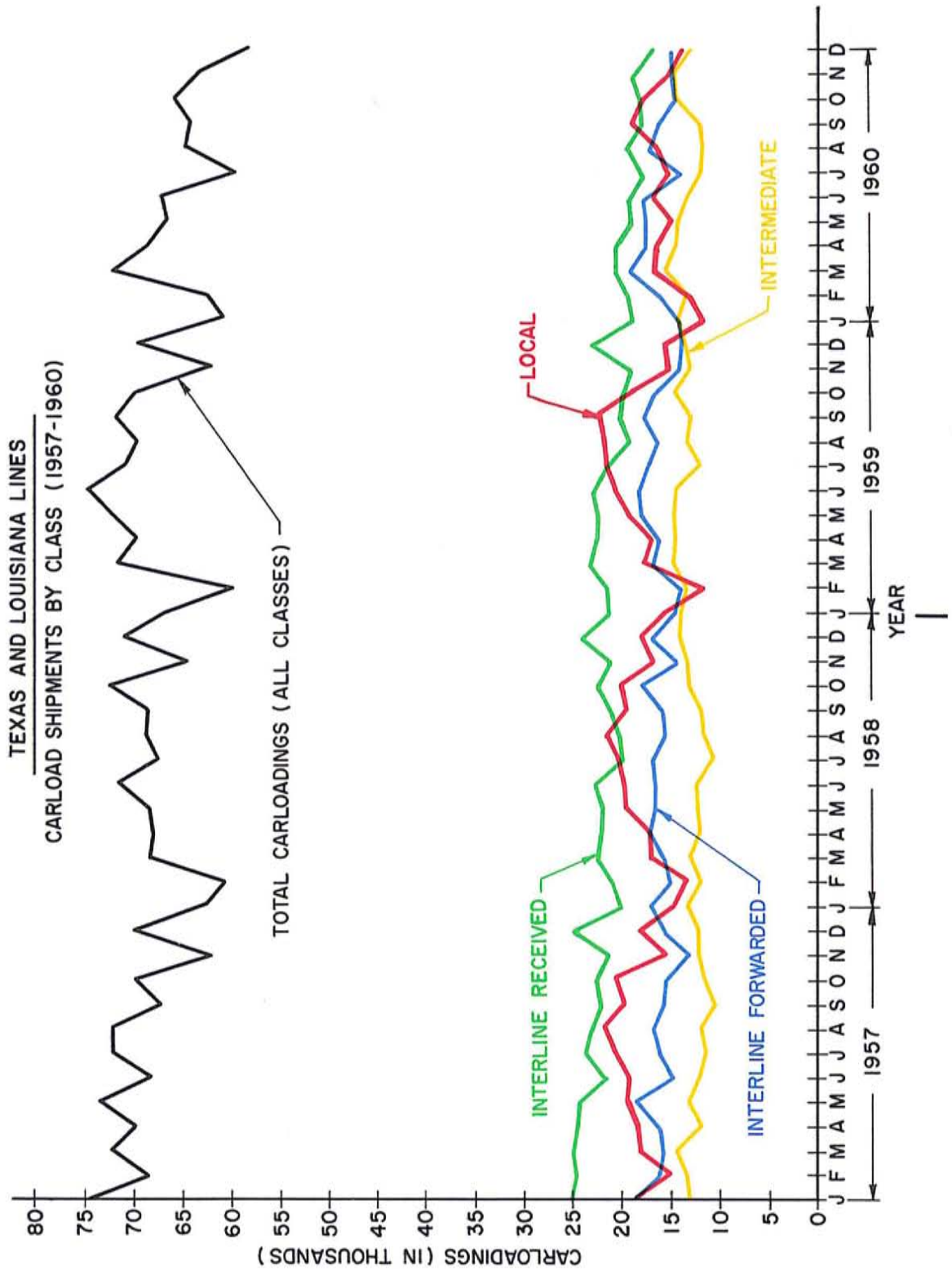

Southern Pacific Company

102717314