

**What would you like to see the Club do?**

Here is your list of recent suggestions and topics:  
 Work out a way thru the gain of a lot of people in the club to reduce the price of components and of micro-computers. . . . continue technical interchange. . . . become a real exchange forum for hardware that *really* can be built as *homebrew* equipment, and not the *blue skys* dreaming of what we could do if we only had a 370/148 monster in our garage as it seems that some of the group have in mind. . . . any comments? . . . programming techniques and hardware design with detailed explanation (seminar format?). . . . serve as a pool for programs, a place to get advice, new ideas, sources of hardware and software. . . . how to get your Altair up and running. How much memory to do what. . . . TTY interfacing. . . . more of just what its doing. . . . help people interested in this field focus on 'who', 'where', 'how', 'when'. . . . help in developing low-cost I/O gear & equipment and IC sources. . . . new equipment, programs, end uses. . . . discussions on hardware & software problems of "Hobby" type equipment. . . . packet switched radio repeater network (see Univ. of Hawaii). . . . provide a forum for ideas. . . . to fit our needs, the club should help those in need find others in need (or others to help). all past member profiles should be published periodically to help this out. . . . mostly what it appears to be doing already. However, we could engage in a development project to design & build our own system that would be faster than microprocessor designs. . . . open exchange of ideas, information, resources, and abilities. . . . teach me how to build a microprocessor/CRT/floppy disc/print, etc., and fill it/them with keen software. . . . supply otherwise unattainable seminars. . . . one member can talk on his experiences to others. . . . places to call for help. . . . for me basics of what's going on, very basic. . . . would like the use of a Fortran program which will give a machine language in which can be used on a small system. . . . continue to exchange knowledge about software and hardware experience and valuable techniques. . . . what members have done recently with micro-computers and peripherals. . . . same as now . . . hardware . . . I/O gear and interfacing problems. . . . share programs, library of circuits. . . . separate business meetings from technical sessions. Plan technical sessions on a subject with demonstrations, for example, CRT terminals. . . . provide means of exchanging soft/hardware ideas. provide members with low cost hardware sources. . . . techniques of hardware design (e.g. interfaces). software methods (serial to parallel conversion for example). . . . keep up with new hardware/software products. . . . provide means for exchange of "want ads", type information. . . . get software and distribute, mass discount buying, hold meetings. . . . everything. . . . how about some sort of introduction to the club? . . . get more people interested in their own computers. . . . interchange

of experience in using available products. . . . hardware and software applications in the home. . . . make micro-computers easy to understand. . . . provide ways of getting cheap parts. provide easy communication among members. . . . say specifically what each part of a CPU does; and what about memory components? How do the 1's and 0's (bits) go thru the different parts, what happens? what comes out? . . . trade skills, programs, define I/O standards. . . . question: what's IBM doing about development of home computers? . . . help me build the Altair. . . . where to get parts, boards, etc. . . . stop talking to everyone like they've been at all the meetings!!! Have more rap sessions!!! . . . just be a meeting of people with like interests that can help each other with problems and sources of parts . . . interested in everything. . . . have a show and tell when a person gets something going.

There it is in your own words. In typing this a sort of poem popped out:

*Don't complain or fuss.  
 It is up to each of us  
 To make the Club do  
 What we want it to.*

By taking the initiative you will encourage others in the Club to become more active.

Thanks to Lee, our "song and dance man," for keeping us from all talking at once, until he declares a random access period. Thanks to Robert for making negatives and positives of the MITS boards, TVT boards, and the memory boards. Thanks to Frank and John for holding off from populating their boards long enough for him to do this. Who knows a source for printed circuits? Thanks to Bob for the Intel Text Editor (runs on an 8080 as is). Thanks to Alex for signing "paid" on the Club's K-200 account at Call Computer. Thanks to Jim for demonstrating his Altair with RGS memory boards. He'll supply a schematic to members interested: 247-0312. Thanks to John for presenting his Suding TV display and fielding questions. Thanks to Alex and his team for giving us a good demo of his TVT. (Will you supply parts or kits?) Thanks to Gerald for donating parts and gear for the digital class. Good luck on your trip. Thanks to Steve for developing an Intel cross assembler (for both the 8008 and 8080) for Lawrence Hall of Science Decision BASIC and giving explanation at the SF/Berkeley HCC meeting last Wednesday. Contact Pete Rowe for use of the system. Thanks to Tom for making up address labels for the newsletter.

New clubs are forming across the country. I've heard of beginnings in Los Angeles, San Diego, Sacramento, New Jersey, Wash., D.C., and Boston. I think this is great. We need more decentralized clubs to help the little guy.

Excerpts from a chalk talk on the Tom Swift Terminal by Lee Felsenstein presented at the June 11, 1975, HCC meeting.

The problem with video display is that nothing remains. You've got a screen and you've got a spot—a spot with a tail—that's a video display. For a TV screen you've got to store the data somewhere. And you have got to keep presenting it as the spot goes across the screen, in the right order, in synchronization, and so forth. So that means you have to have a memory.

Until recently, memory consisted of a bucket brigade: shift registers. Since this spot crosses the screen in a continuous pattern—it is always starting at the top line, going thru, and winding up at the bottom line—you need to get that information out of the memory, to the screen, in a repeatable order. And shift registers were made for that. It is basically sort of a pipeline. You trickle stuff in and you get stuff trickling out, and in between the two there is a lot of storage. It is looped around like some kind of air conditioning radiator. And you can get to it here; but you can't get to it in there. If it is somewhere in the middle, you can't jump at it and say gimme that bit. You've got to wait, until it comes around. And this has some restrictions. That is how the first TV typewriters were built—with shift registers.

With his mind thinking one step ahead of where he is, Don Lancaster said let's use the newly available random access memory. And that is a little better described as a pigeonhole. And, yes, you can jump in any place you want, but you've got to tell it where you are going. So then you've got to have some counter that keeps saying "give me the next, give me the next..." And because of the physics of the display, you have to repeat that. You have a data line, which is like a line of characters, and that is composed of at least seven scan lines—for a 7 by 5 character matrix. And the information is repeated each scan line, shifting down one more position in the character generator.

Lancaster says he's invented a TV Typewriter II. It's going to have random access memory. I wasn't the first one, I'm sure, but I realized that you could treat this as a piece of your computer memory. You could jump right in and change a bit or word without having to wait for the whole thing to trickle through and have some crazy kind of bookkeeping circuit there if you want to insert a character. It is not so easy with RAM, but with shift registers its really weird. You have to have some place to store an extra character and then put the one you just got into the pipeline and keep shuffling—sort of stretch the line until the end comes by. Well, anyone who's played with these things. . . yea. So, Lancaster came up with TV Typewriter II, only someone else beat him out with the design.

Where I was at this time was involved with Resource One doing public access information retrieval system. We put a terminal in a store and a library. No operator; open to the public. People would come up, hands-on, and would put information in like it was a bulletin board, and search for information. It was very successful; ran for 14 months. During that time people were coming to me, saying, how about a cheap terminal? We can't get terminals cheap enough and they don't work when we get them.

So I started thinking of how to do it right. We wanted a cheap terminal that would survive with untrained people using it—pass a spilled coke test. It had to be reliable. *We couldn't think of anyway to do that reliability in hardware.* Encase everything in epoxy? There is another approach which we came up with: *incorporate the user into the design.* Take the place where the terminal is going to be installed and turn that into a little computer club. Then you've got your own service organization there, and they can get on very intimate terms with the equipment. And make it work their way. What this means is putting sort of a hobby center into each terminal. That is not a very good way to express it, but that's the idea. This means building a device which can be expanded, and be modified, and is visible, is understandable, is *convivial*. [Ivan Illich's term. Read: *Tools For Conviviality*, 1973, Harper & Row] From this approach we focused on the RAM idea. You are halfway to a computer, if you use random access memory and you make access to that memory easy and rational. *Look at a terminal as a little pot of memory.* How can that memory be made maximumly available to people outside it? And how is it to grow and allow people who handle it to manage that growth? . . . [Talk continued with more detail.]

#### Hardware:

The LSI-11 uses four 40 pin DIP's: control chip, data chip, and two microcode read-only-memory chips which store the PDP-11/35, 11/40 instruction set, resident octal debugging technique, resident ASCII/console routine and bootstrap. The PDP-11 repertoire has over 400 hard-wired instructions—no separate memory, I/O, or accumulator instructions. The basic order code uses both single- and double-operand address instructions for words or bytes. Addressing modes include sequential addressing forward or backward, address indexing, indirect addressing, 16-bit word addressing, 8-bit byte addressing, and stack addressing. Variable length instruction formatting allows a minimum number of words to be used for each addressing mode. For more information call Digital Components Group toll free between 8:30 AM and 5:30 PM EST 800-225-9480.

The SPHERE HOBBIEST SYS1/KIT cost \$650 prepaid before Sept., 1975. Kit includes: processor module (CPU1) using Motorola's M6800 microprocessor, 1K or reprogrammable ROM, 4K dynamic RAM with refresh circuitry and real time clock; display module (CRT1) 16 lines by 32 characters format with interface for standard TV; 73 key keyboard and interface (KBD1); power supply (PWR1); power cable (PCB1); three buss cables (BCB1); and Operator/Reference package (OPR1). Under 60 day delivery on all initial orders (shipping cost to be paid by purchaser). For more information contact Michael Wise, SPHERE 96 East 500 South - Bountiful, Utah 84010 or call 801-295-1368.

4KRA (4096 x 8 RAM) Static Memory Module plug-in compatible with Altair 8800. Fast: access time 520 nanosec. max.; low power: 5.0W typical at 25° C. Kit price \$225. For more information call Robert Marsh at Processor Technology Co. 2465 Fourth Street, Berkeley, Ca. 94710 (415-549-0857)

Ken McGinnis is willing to be the club buyer for the Phi-Deck tape transport for cassette tape. Send \$100 to him at P.O.Box 2078 San Mateo, Ca. 94401 (If over 50 units are sold, you get \$18 back.)

American Microsystems is the second source supplier for the M6800. The AMI 6800 microprocessor manual is available, call 415-969-0610.

For Sale: Cybercom Tape Deck, complete documentation and lots of tape, \$225. Also TTL IC's 7402, 14,16,23,70,73,76,82,85 these are new bin 1 parts made by TI. Will sell any quantity to club members at 50% less than surplus prices. Call Herman Poole 263-3078.

ASR-33 TTY Model 3320-3JC new from the factory \$969 in any quantity four to five month delivery. Burney Mansolf 312-982-3378.

P9102 APC 500 ns access, 100-999 quantity \$2.78 each. Quote from Mr. Bailley, Advanced MicroDevices 408-732-2400. Go to Cramer.

Robert Baer has source for 1702 A's surplus, but guaranteed good, \$10.00 each, but we need a minimum order of 80. Bring your money to next meeting.

#### Software:

I want to start a class in programming. I need to know how many people are interested, and what they expect to learn. Based on the results of this poll, I will define the class objectives, and expect to run one nite (in my home) starting in the fall. Call 408-578-4944. Tom Pittman 469 East Branham Lane, San Jose, Ca. 95111.

Request for a 4040 assembler package. Please call Ted Netoff in Oakland 415-530-3173. Thanks.

*Machine Language Programming for the 8008 (and Similar Microcomputers)*, manual includes: fundamental techniques, loops, masks, counters, pointers, search and sort routines, floating point arithmetic package, programming for PROM's, etc. \$19.95 postpaid from Scelbi C. C., Inc. 1322 Rear - Boston Post Road, Milford, Ct. 06460

#### Announcement:

MITS is having an Altair Seminar at Rickey's Hyatt House in Palo Alto Room July 9th at 9 AM. Check with Repco Paul Terrell 415-965-8581

George A. Barker 926 Roundhill Rd., Redwood City, Ca. 94061 (366-0133) designing a TV TTY. Skill: digital electronic techniques. Hopes to get either an 8008/8080 working this summer.

Jim Brick 820 Sweetbay Dr., Sunnyvale, Ca. 94086 (247-0312) (work tel. 257-6550) has Altair 8800 with RGS buss, planning a CPU to CPU (dual processor), prom burner, general I/O. Use: design, program, etc., process controllers (small CPU 4040) to be done thru 8080 as a means of communication, also general purpose home computing. Experience in large computing operating systems. Currently Sr. Systems Analyst for Tymshare Inc. on their 370/158 running VM/370. Needs: electronics for digital tape recording.

Howard Bornstein 9969 Alba Rd. # 3 Ben Lomond, Ca. 95005 (408-336-2468) has HP-65 and plans to build Altair 8800.

Rick Bromagem 8286 Lancaster Dr. # 31 Rohnert Park, Ca. 94928 has Altair 8800, TVTypewriter II, and 8K memory. He is planning a 16K system with FORTRAN or ALGOL and tape cassette storage. Use: for research programs and possible business doing software and hardware for OEM's on contract. He has Western Digital memory (4K) and communication chips and has a contact with factory rep. who is quoting 100 quantity prices. Needs access to prom programmer fusible link type. Question: Does anyone have any real and realistic plans to attempt a hook-up of two microcomputers in the future when I/O and memory in?

David W. Corbin 3729 DeLa Cruz Blvd. Santa Clara, Ca. 95050 (984-3378) has Altair 8800, paper tape reader/punch, SCM type-writer. Building interfaces for above and mag cassette I/O. Use: to learn 8080 programming. Experience: 15 years electronic eng. in automation field. Need manuals on SCM Typetronic 9816 and SCM Mod 607800 papertape punch.

John Curtis 1849 Limetree Lane, Mountain View, Ca. 94040 (968-4190) just received Altair 8800 and needs memory for it. Has some prom programmers: Sig-FSC-NSC-TI Fusible link.

Greg Dolkas 2121 Bellview Dr., Palo Alto, Ca. 94303 (327-4945) has lots of chips--not much together. Building a 16 bit mini with own instruction set, architecture, etc., it should have 2 micro sec. instruction cycle, hardware stack, more! For use as a conversation piece? Skill: systems programmer and into hardware. "I have most of the parts for TVT I and would like to sell or trade for TVT II."

Steven J. Dompier 2136 Essex St., Berkeley, Ca. 94705 (841-1868) (547-4069) "I have an Altair 8800 up and running (mostly around in circles right now) and an ASR 33. I am working on a modem, TV graphics display, and of course memory and other boards for the Altair. I am now gathering info on the LSI-11, which looks like a really worthwhile system that amateurs could build. Use: graphics, information handling, games, community memory input, have fun, get mad at, explain, learn from, help defray the image computers have in the average public mind, and . . . Knowledge gained so far by building Altair, gadgets, and so on. Need: LSI-11, IFlat screen TV (dot matrix), used disk.

John Drace Rm E-002 Stanford Medical Center, Stanford, Ca. (493-7829) planning an Altair system: 64K, 2 floppys, 1-64 Serdex Mods (up to 4096 analog lines), 2 SWTP TVTerminals. for use in real time building automation system. Experience: software: Nova systems programming, realtime bio measurements, signal analysis. Need: DOS type software for Altair (peripheral drivers: disk, printer).

Peter B. Dunckel 52 7th Ave. San Francisco, Ca. 94118 (home 823-5382, work 387-8566) wants to build a computer on 8008 or 8080 for math and games (spherical astronomy). Need I/O gear.

John Dunfield 19874 Viewridge, Saratoga, Ca. 95050 (446-0436) has 1K Altair for use in model railway control. Need Teletype; assembler & code conversion. Would like to hear recommendation for some basic math text package approach for standard algorithms.

Peter Ecclesine 2361 Laura Lane, Mountain View, Ca. 94043 (968-8044) plans to get M6800 ANK/CRT in Aug. Experience: 3 years Assembly language CDC 160a, UNIVAC 1230mrc, real time, designed control & monitor systems (8080 based). Need 8080 PL/M and efficiency of compilations.

Roy Elder 1953 Tia Place, San Jose, Ca. 95131 (251-0407) plans a 8008 8 or 12K system to use in learning and to get a job in the computer field. Anybody that has a system running, I will be available for trade of my time for system time, open for negotiations.

Gary B. Fariss 969 Durlane Court, Sunnyvale, Ca. 94087 (408-732-8259) W6KYF 2 meter gear on Local Repeater. Have 80 char by 27 line TV terminal -- TTY compatible--64 char set., totally homebrew. Modem connected to phone, no intelligence, 110 and 300 BAUD. Working on 27 x 80 -- 128 char set -- DMA access display, intended to interface to 8008 processor/memory system which is not built, but is designed. Will probably re-design for Altair compatible. Use: Intelligent terminal and RTTY  $\rightleftharpoons$  ASCII, ASCII  $\rightarrow$  morse code for ham radio. Experience: CDC 6000 operation -- FTN 4 -- 6000 compass assembler. Need: Altair prints for CPU, 4K memory, DMA channel, parallel I/O, serial I/O.

Ken Feil 917 Cloud Ave., Menlo Park, Ca. 94025 (854-5258) has a MCS-8 (my own design) and plans TVTTY (own design) similar to TVTTY II. Use: games, data storage, ? Experience: unofficial design engineer. Need: 8008 resident system monitor, resident assembler, and text editor, BASIC compiler. "For people who are building Mark-8's I have a better design."

Terry Fowler 1390 Sagehen, Sunnyvale, Ca. 94087 (249-4765) plans on getting an Altair for entertainment and custom applications. Experience on Intel 4004. "I'm having some universal boards for the Altair made."

David Gjerdrum P.O. Box 7201 Santa Rosa, Ca. 95401 (528-7216) buying Altair for programming use.

Frank Harvey 8186 Terrace Dr., El Cerrito, Ca. 94530 (415-524-7982) has Altair with 1K. Planning to build line printer, keyboard, & cassette storage. Use: study & design compilers, sail making problems, tax work. Need: cheap modem, any and all help & advice on TV displays.

Julian Hernandez 1015 Continental Dr., Menlo Park, Ca. 94025 (854-5003) has time share terminal with Call Computer. Thinking about purchasing an Altair for hobby use and business. Have ASR 33.

Bruce R. Kendall 334 A Camille Ct., Mountain View, Ca. 94040 (967-3613) "I was thinking about building a system using an Altair until I saw how slow it ran BASIC." Have some home shop equipment (drill press and 3" lathe). Would like to start out with a tymeshare terminal & printer.

Kenneth Koll 12685 Lompico Rd. Felton, Ca. 95018 is gathering parts and info for an 8008 or 8080 system. "Initially I want to build a general purpose video game with different games stored on cassette. Once I get a processor and memory together I'm sure there will be other trips. I am an electronics tech by trade. I am reasonably adept in digital (hardwired) and analog design and PC fabrication. On a limited basis I can make available a moderately well equipped college lab in the Santa Cruz area (scopes, counters, pulse generators). Need: all the information I can get my hands on about programming these beasts. I have never dealt with machine codes before.

Ted Kramer 475 Encinal Ave. APT B, Menlo Park, Ca. 94025 (328-1590) have imagination, planning maybe an Altair, maybe a 16 or 32 bit something. To have fun, make money, make friends. Experience in programming systems Applications (business, manufacturing). Need: everything-- "How do you hold a soldering iron?"

Jerry Lawson 3080 Olcott St. Suite 210 A, Santa Clara, Ca. 95050 (408-244-1400) Field Application Engineer Fairchild. Experience: digital design, software prog. local F-8 microprocessor applications.

Jim Leek 2801 F Street, Bakerfield, Ca. 93301 (805-327-2725) have an Altair on order for use in bookkeeping or play. Need: Altair expandability; mass memory, I/O, BASIC language. "Anyone know how to connect an Altair to a Decision Data 96 column key punch. I'd like to use it to translate cards into tape.

Mel Lehr 2770 Fleetwood Dr. San Bruno, Ca. 94066 (589-7703) planning on an 8080 or similar system to control chemical analysis instruments such as infra-red spectrophotometers, atomic absorption, etc., also machine control equipment such as lathes--milling eq. Presently work for Perkin-Elmer Corp. as a service rep. Need; recommendations on where to purchase an 8080 system at the best price in the near future.

Clarence A. Lewis 3624 Eastwood Circle, Santa Clara, Ca. 95050 (home 244-2881, work 493-3000) plan on getting a RGS micro (8008) and TVT with cassette-interface for use in credit card, check, and grocery billing ; taxes, games, etc.

Robert Marsh 2465 Fourth St. Berkeley, Ca. 94710 (841-8678) (business 415-549-0857) Altair 8800, TVT, and plan on building 8008 system using MIL pc boards, also Altair BASIC and disc. Would like to get a hold of a DEC LSI-11 system just for fun. I am an owner of Processor Technology Company which makes plug-in compatible memory and I/O cards for the Altair 8800. Our products are extremely well made and are quite inexpensive. Low power 2102 RAM's are available to club members for \$4.25 each in any quantity. Free flyer on request.

Robert A. McAllister 12464 Scully Ave. Saratoga, Ca. 95070 (home 252-4177, business 378-2450) have Altair 8800, need TVT.

K. A. McGinnis P.O. Box 2078 San Mateo, Ca. 94401 building an Altair, Suding TVT, & calculator interface to play and experiment.

Roger Melen 565 Arastradero # 304 Palo Alto, Ca. (493-6455) have Altair 4K, 1256 + serial interface for ASR33, Cyclops and Cyclops interface. See cover Dec. '75 P. Elec. (color TV peripheral for Altair. ) arrives in Nov. '75.

Bob Nelson 2758 Canyon Creek Drive, San Ramon, Ca. 94583 (415-837-2131) have 15 MHz Scope, counter, DVM, VOM, P.S.

Kenneth Nonomura 416 Duncan Street # 5 S. F., Ca. 94131 (285-5062) have KSR 33 & Omnitech coupler for timesharing. Would like to build unit like Altair 8800 with TVT typewriter & perhaps floppy disc. Use: run stock & commodity data primarily, also recreational uses. Background in electro-mechanical tech. for office equipment. "I need to catch up with you guys."

John Ogle 1472 Pashote Ct. Milpitas, Ca. 95035 (263-3798) plan on an Altair or equiv. for games and scientific calculations.

Neil Pering 2803 Kipling St. Palo Alto, Ca. 94306 (321-2714) have Altair 8800 with 256 words, plan on TVT, special interfaces, digital test equipment. Use: control environment (solar heating). Experience in analog engineering, perhaps digital troubleshooting.

Ka Poon 2051 Hoke Dr., Pinole, Ca. 94564 "I am waiting for the prices to go down more." Use: to play games, do homework.

Mark Robinson 3637 Sonoma Ave. Apt 112, Santa Rosa, Ca. 95405 (707-525-1659) getting Altair kit + 16K memory, eventually TTY, cassette interface, 2 floppy discs and controller. Use: write educational programs, recreation, editor, search programs. Experience: programming, operating systems, teleprocessing, assembly language.

Matt Sanders 1315 Cornell Ave., Berkeley, Ca. 94702 (525-1933) planning on setting up a system using Motorola 6800 chip set, keyboard, TVT for use teaching children. Experience: electronic technician, programmer (on 360 mostly). Need a better scope.

Ray Stevens 3650 Charles St. Suite K, Santa Clara, Ca. 95050 (408-247-0158) have two 008A RGS Microcomputers with keyboard and audio cassette. Building CRT, scientific calculator I/O, teletype interfaces, ROM boards and programmer; M6800 micro-computer. Need information on 5-level teletype for interface building purposes; also info on what people are interested in buying.

Mary Streeter, Five Willows Computing, 1142 Brown Ave. Lafayette, Ca. 94549 (415-284-4666) have Altair 8800, 8K, TTY. Use: aid to present consulting jobs, at home means fewer baby sitters! Skills: software only, would really benefit from contact with people into hardware.

Earl R. Tillman 277 Cresta Vista, San Jose, Ca. 95119 (408-225-1572) have DEC LSI-11 on order. Use: games home accounting, play.

Dennis Tremain 1950 Cooley Ave. # 4210, East Palo Alto, Ca. 94303 (323-4993) "I am thinking of trying to build up a halfway decent small scientific computer of some kind and play with it generally." I'm especially interested in whether anyone has built up a compiler for a reasonably high level language for such a machine.

Bob Wiekping 1901 Halford Ave. # 160, Santa Clara, Ca. 95051 (244-6993, 246-7501 x2557) would like to make something balance a checkbook and measure a voltage. Ultimately, I'd like to learn an assembly type language so I can get a feel of what microcomputers are good for. Need: instruction in use of microcomputers; also need a micro computer.

Dio Wier 2755 Seventh St. Boulder, Colorado 80302 (303-442-5448) working on software for home computers. use: games, maybe message switching, income tax program, home medical advisor, legal advisor, recipe program for the young lady. Have 10 years experience as a computer systems analyst; also used to be a transmitter engineer, worked on R & D at LRL, Berkeley. Need: "The whole ball of wax."

Randy Wigginton 806 Logan Ct. Sunnyvale, Ca. 94087 (732-1656) planning to get Altair 8800 to play games.

Michael R. Witham W6PTK 1655 Longspur, Sunnyvale, Ca. 94087 (245-0972) have 8008, video display & parts with which to make a small home computer. Use: games, video, and ham radio use, and some bookkeeping. Need: keyboard.

#### Club Treasury Report:

INCOME: Collected at MITS Mobile Seminar June 6 \$12.00. Collected \$58.00 at June 11 meeting and \$18.00 at June 25 meeting. Received \$45.00 in the mail. Total income: \$133.00.

EXPENSES: Fourth newsletter printing cost \$25.44, postage \$22.50, xerox \$2.19, 3x5 cards \$1.24. Total spent: \$51.37.

OLD BALANCE: June 5, 1975, \$47.58.

NEW BALANCE: As of July 2, 1975, \$129.21. Cost of this newsletter has not been deducted. About 300 will be printed and mailed (estimate cost to be \$65 - \$80). We request a dollar donation from all new attenders and encourage regular club members to contribute from time to time. Please fill out a Club Survey Questionnaire to let us know what you have to share and what your needs are.

**NEXT MEETING: WEDNESDAY, JULY 9, 7 PM at Stanford Linear Accelerator Center in the Auditorium. We meet here every two weeks (July 23, August 6, etc.). Everyone welcome; bring something to show or share.**

#### Publications:

The latest *CoEvolution Quarterly* (Summer 1975 \$2.) includes a 17 page section on "Personal Computers" edited by Marc Le Brun. Plans are to continue this section in future issues. Subscriptions are \$6.00 per year. *CoEvolution Quarterly* Box 428 Sausalito, Ca.

The latest *People's Computer Company* newspaper (Vol. III, # 6) is devoted to a look at hardware. Subscriptions are \$5.00 for 5 issues (Vol. IV starts in Sept.). *PCC* Box 310 Menlo Park, Ca.

Lee Felsenstein is initiating a monthly periodical (hopefully) called: *The Journal of Community Communication* to encourage dialog concerning non-hierarchical communications systems which can be created and used by people in their daily lives as members of communities—such as applications of computer technology and microcomputer devices in information networks and public memory systems. He suggests a dollar per issue and welcomes letters, ideas, opinions, etc. Write: LGC Engineering 1807 Delaware St. Berkeley, Ca. 94703 (415-845-4736).

The first issue of *BYTE!* will have 96 pages including an article on serial interfaces for TVT's by Don Lancaster, an article on surplus keyboards, an article on assemblers, an article on how to recycle IC's from PC boards, a review of the RGS-008A Kit, and other notes, info, letters, and advertisements. Introductory subscription rate is \$10.00. *BYTE!* Green Publishing, Inc. Peterborough, N.H. 03458

*Micro-8 Newsletter* is still the best for letting us know what micro-computer experimentors are doing. Subscription is \$6.00 for six issues. *Micro-8 Newsletter* Cabrillo High School Computer Center, 4350 Constellation, Lompoc, Ca. 93436

## DESIGN NOTES: Arbitrary Logic Function Generation Via Digital Multiplexers

Terry Lee, Consulting Engineer, Tamar Electronics  
2400 Geary Blvd. # 6  
San Francisco, Ca. 94115

It happens too often, I would say, that in the course of designing combinational logic circuits I run across problems that seem to require an inordinate amount of gates. When such problems arise the solution is a digital multiplexer. Figure 1 shows a truth table; using A, B, and C we want a circuit that will generate Q. This may be simple using gates, I have not tried, but for illustrative purposes we will solve the problem using a 74151 digital multiplexer.

C	B	A	Q
0	0	0	0
0	0	1	1
0	1	0	1
0	1	1	0
1	0	0	1
1	0	1	0
1	1	0	0
1	1	1	0

Fig. 1

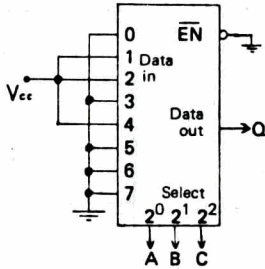

Fig. 2

In order to implement Fig. 1 connect the select inputs,  $2^0$ ,  $2^1$ , and  $2^2$ , to A, B, and C and the data inputs to the appropriate logic level. When CBA = 100 the logic level at data in 4 will appear at the output. Since Q = 1 is desired, data in 4 must equal 1. Figure 2 shows the completed circuit.

Suppose we now have the truth table shown in Figure 3. It would seem that with four variables we must use a 1 of 16 multiplexer, but this is not so.

D	C	B	A	Q
0	0	0	0	0
0	0	0	1	1
0	0	1	0	0
0	0	1	1	1
0	1	0	0	0
0	1	0	1	0
0	1	1	0	1
0	1	1	1	0
1	0	0	0	0
1	0	0	1	1
1	0	1	0	1
1	0	1	1	1
1	1	0	0	0
1	1	0	1	0
1	1	1	0	0
1	1	1	1	0

Fig. 3

D	Q
0	0
0	0
0	0
0	0
1	0
1	0
1	0
1	0
1	0
1	0
1	0
1	0
1	0
1	0
1	0
1	0
1	0

Fig. 4

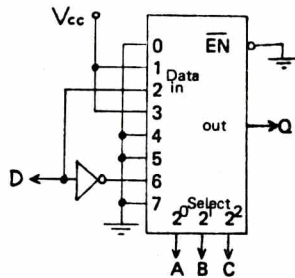

Fig. 5

The same 1 of 8 multiplexer that we used above can be used by connecting the extra variable to the appropriate data inputs. Any variable can be designated for this use. To start we will select D as the extra variable and rewrite the truth table as shown in Figure 4.

It can be seen that when CBA = 000, Q = 0 irrespective of D; therefore, data in 0 should be connected to logic 0. When CBA = 001, Q = 1 irrespective of D; therefore, data in 1 should be connected to logic 1. When CBA = 010, Q = D; therefore, data in 2 should be connected to D. The completed circuit is shown in Figure 5.

In order to assess the possibility of eliminating the inverter and minimizing the fan out required for the extra variable all cases should be tried. Figures 6 thru 11 show truth tables and completed circuits using A, B, and C as extra variable.

D	C	B	A	Q
0	0	0	0	1
0	0	1	0	1
0	1	0	0	0
0	1	1	1	0
1	0	0	0	1
1	0	1	1	1
1	1	0	0	0
1	1	1	0	0

Fig. 6

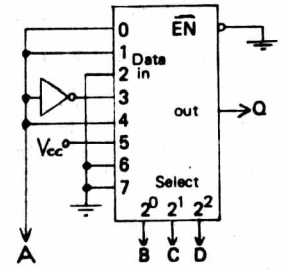

Fig. 7

D	C	A	Q
0	0	0	0
0	0	1	1
0	1	0	0
0	1	1	0
1	0	0	0
1	0	1	1
1	1	0	0
1	1	1	0

Fig. 8

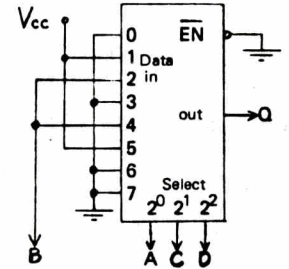

Fig. 9

D	B	A	Q
0	0	0	0
0	0	1	0
0	1	0	0
0	1	1	0
1	0	0	0
1	0	1	0
1	1	0	1
1	1	1	0

Fig. 10

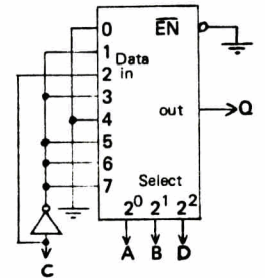

Fig. 11

The best solution seems to be B. It should be noted that it is not always possible to eliminate the inverter. In some cases even five variables can be handled by a 1 of 8 multiplexer by using the enable input, if one exists. For this to work one of the variables must have a constant output for one of its values. Suppose Figure 3 had a fifth variable, E, and when the table was rearranged as recommended we arrived at Figure 12.

D	C	B	A	E	Q
0	0	0	0	0	0
0	0	0	1	0	1
0	0	1	0	0	0
0	0	1	1	0	1
0	1	0	0	0	0
0	1	0	1	0	0
0	1	1	0	0	1
0	1	1	1	0	0
1	0	0	0	0	0
1	0	0	1	0	1
1	0	1	0	0	1
1	0	1	1	0	1
1	1	0	0	0	0
1	1	0	1	0	0
1	1	1	0	0	0
1	1	1	1	0	0

Fig. 12

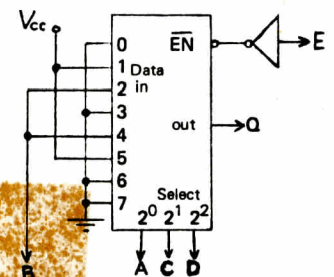
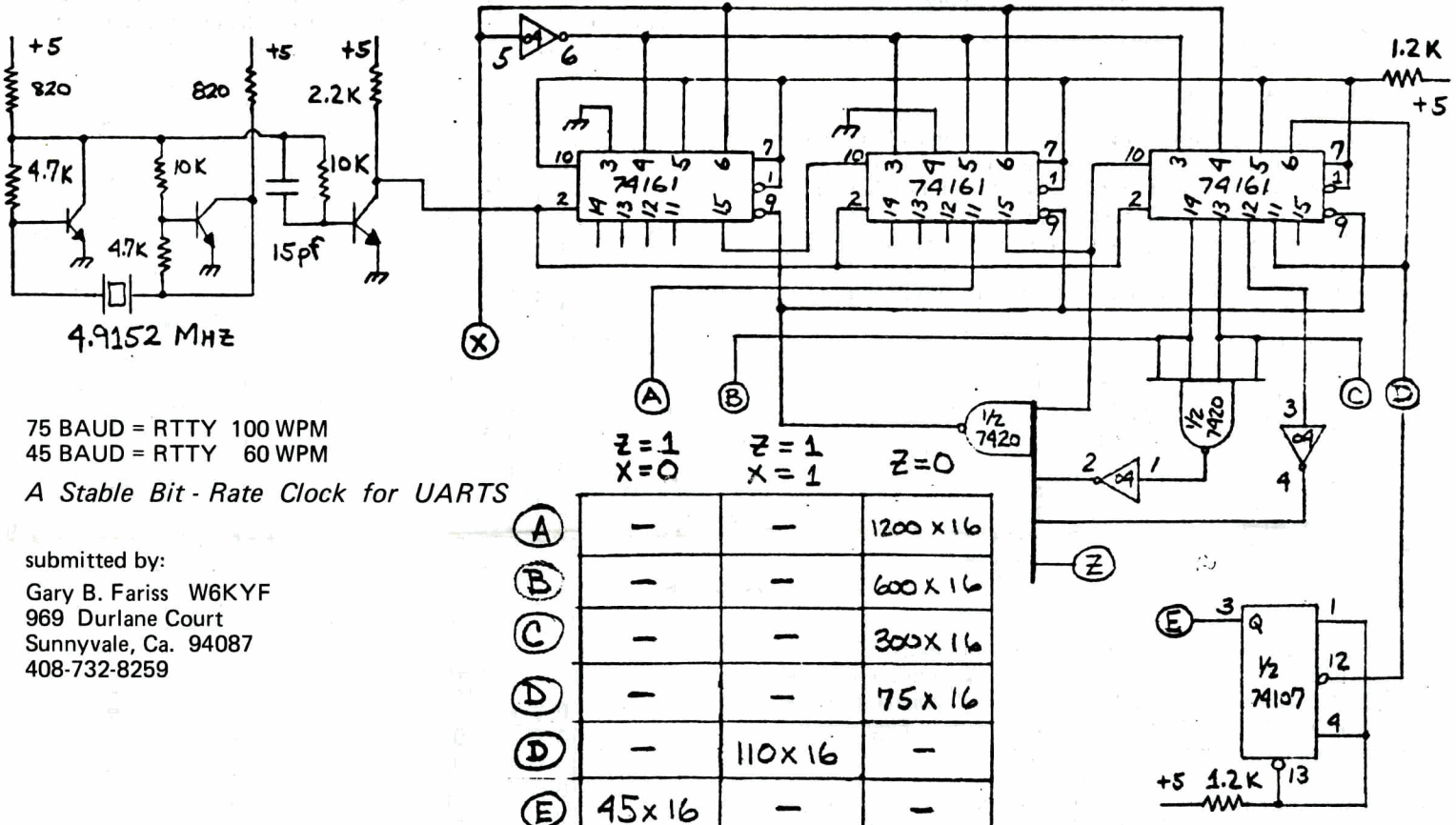

Fig. 13

It is seen that when E = 0, Q is constant (0). In cases like this the enable input is assigned to the extra variable that causes it to appear. Figure 13 shows a complete circuit for the five variable table shown in Figure 12.

By using a 1 of 16 multiplexer the maximum possible number of variables is six which should be enough for most applications.



75 BAUD = RTTY 100 WPM  
 45 BAUD = RTTY 60 WPM

*A Stable Bit-Rate Clock for UARTS*

submitted by:  
 Gary B. Fariss W6KYF  
 969 Durlane Court  
 Sunnyvale, Ca. 94087  
 408-732-8259

$Z=1$      $Z=1$      $Z=0$   
 $X=0$      $X=1$

(A)	-	-	1200 x 16
(B)	-	-	600 x 16
(C)	-	-	300 x 16
(D)	-	-	75 x 16
(D)	-	110 x 16	-
(E)	45 x 16	-	-

Frequency Table

FRED MOORE  
 558 Santa Cruz Avenue  
 Menlo Park, Ca. 94025

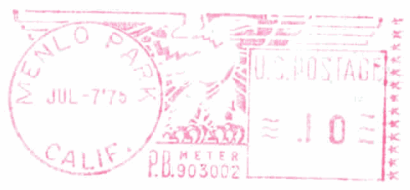
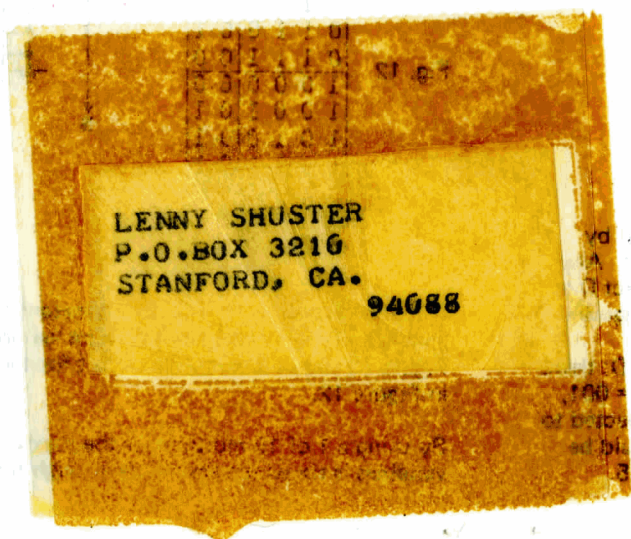

FIRST CLASS MAIL