

INTRODUCTION

This *Operator's Manual* contains instructions for installing and operating the printer.

The operator has four principal jobs to do:

- loading paper;
- verifying printer readiness, and setting the printer on-line;
- changing the ink ribbon, as required;
- cleaning the printer periodically, or as required.

Operating Instructions in the following pages outline procedures for doing each of these jobs. Instructions and procedures

for installing the printer follow the *Operating Instructions*.

Detailed interface and configuration information, procedures for communicating with the printer, and command and data format descriptions, are contained in the *Applications Manual*.

Information for maintaining and repairing the printer is contained in the *Maintenance Manual*.

A separate *Drawings Manual* contains electrical and logic diagrams for the printer, and a *Parts Manual* identifies and defines parts of the printer.

WARNING: THIS EQUIPMENT GENERATES, USES, AND CAN RADIATE RADIO FREQUENCY ENERGY AND IF NOT INSTALLED AND USED IN ACCORDANCE WITH THE OPERATOR'S MANUAL, MAY CAUSE INTERFERENCE TO RADIO COMMUNICATIONS. IT HAS BEEN TESTED AND FOUND TO COMPLY WITH THE LIMITS FOR A CLASS 'A' COMPUTING DEVICE PURSUANT TO SUBPART 'J' OF PART 15 OF FCC RULES, WHICH ARE DESIGNED TO PROVIDE REASONABLE PROTECTION AGAINST SUCH INTERFERENCE WHEN OPERATED IN A COMMERCIAL ENVIRONMENT. OPERATION OF THIS EQUIPMENT IN A RESIDENTIAL AREA IS LIKELY TO CAUSE INTERFERENCE IN WHICH CASE THE USER AT HIS OWN EXPENSE WILL BE REQUIRED TO TAKE WHATEVER MEASURES MAY BE REQUIRED TO CORRECT THE INTERFERENCE.

PRINTED IN U.S.A.

OPERATING INSTRUCTIONS

Except for the ac power switch (located on the base at the left-hand end of the printer), electrical controls and indicators are located on the Operator Panel (figure 1). Table I lists each control and indicator and describes its function.

To operate the printer, proceed as follows:

- a. Set AC Power switch (on left-hand side of base) to ON position. POWER indicator should light.
- b. If paper is not already in the printer, load paper following instructions in *Loading Paper*, then close the front cover.
- c. If the Mechanical VFU (option) is to control form printing, load the program

tape loop prepared for that form, following instructions in *Loading Mechanical VFU*.

- d. If printer contains the Forms Length Selector option, set Forms Length Selector switches following instructions in *Setting Forms Length Selector*.

- e. Press TOP OF FORM pushbutton to set top of the next form at the print station.

- f. Use 8LPI pushbutton to select line spacing. Indicator is on for 8LPI, off for 6LPI.

- g. Press ON LINE pushbutton. ON LINE indicator should light indicating that the printer is ready to respond to incoming

data. The shuttle drive motor will start and the printer will then wait for data.

If CHECK light is on, check for the following conditions:

- a. The printer has run out of paper,
- b. paper has jammed in the printer,
- c. Forms Thickness Adjustment Lever has been left in the "Load" position,
- d. Clutch Lever on the Mechanical VFU (option) has been left disengaged, or
- e. an internal dc power supply has failed and maintenance is required.

(continued)

OPERATING INSTRUCTIONS FORMS LENGTH SELECTOR/MECHANICAL VFU OPTIONS

LOADING PAPER

UNLOADING PAPER

CHANGING RIBBON/CLEANING

UNPACKING THE PRINTER/INSTALLING THE PRINTER

CONFIGURING THE PRINTER/FUNCTIONAL CHECKS

INTRODUCTION

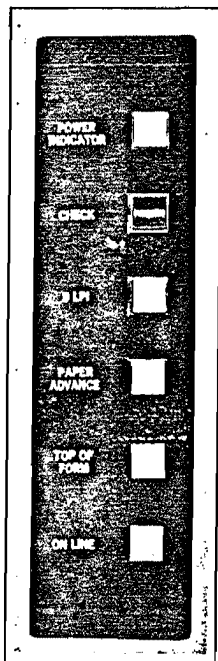

Figure 1.

Table 1 Controls and Indicators

Control/Indicator	Function
Power on/off toggle switch	Turns-on ac power to printer.
POWER indicator	Lighted when ac power switch is turned on.
PAPER ADVANCE pushbutton	While held down, causes paper to advance.
CHECK pushbutton/indicator	Lighted when: <ul style="list-style-type: none"> —paper is not loaded, —paper has run out, —paper is jammed, —Clutch Lever on Mechanical VFU (option) is not engaged, or —any internal supply voltage is abnormal. Light goes out when fault is cleared, except CHECK pushbutton must be pressed after paper motion fault is cleared.
TOP OF FORM pushbutton/indicator	Momentary-action switch causes paper to advance to top of next form (or to Channel 1 is VFU if loaded). Operational only when printer is off-line. Lights only when Electronic VFU is loaded, or when a tape is installed on the Mechanical VFU. Always on if printer includes optional Forms Length Selector.
8LPI pushbutton/indicator	Momentary-action switch selects line spacing of either eight lines per inch (lighted), or six lines per inch (unlighted). Operational at Operator Panel only when printer is off-line.
ON LINE pushbutton/indicator	Momentary-action switch enables printer control through the interface (lighted), or disables the interface (unlighted). Printer cannot go on-line if the CHECK indicator is lighted.

SETTING FORMS LENGTH SELECTOR

If the printer includes the optional Forms Length Selector, and if the Electronic VFU is not used, selector switches may be set to establish the desired form length. Two thumbwheel switches are used to preset any form length up to 16½ inches in sixth-inch increments. The switches are located on a module attached at the right-hand front of the printer mechanism.

To select form length, proceed as follows:

- a. Open printer cover.
- b. To determine switch settings, multiply the form length, in inches, by six. For example, to select an 8½-inch form, set switches to 51 (8½ x 6).

NOTE

- Never start printer operation with Forms Length Selector switches set at 00. A setting of 00 will cause the Forms Length Selector to advance paper without control.
- c. Close printer cover. Note that TOP OF FORM indicator remains on with this option installed.

LOADING MECHANICAL VFU

If the Mechanical VFU (option) is to be used to control forms printing, load the program tape as follows:

- a. Open printer cover.
- b. Select program tape prepared for the form to be printed and position over Vertical Forms Positioning Knob with small sprocket holes to the right of tape center.
- c. Lift Tensioning Arm (figure 2) to its fully raised position.
- d. Slip tape over Vertical Forms Positioning Knob and into slot in read head, with tape encircling both roller on Tensioning Arm, and Sprocket Drum (figure 3). Be sure that sprocket pins engage holes in tape.
- e. Gently lower Tensioning Arm to tension tape.
- f. Raise Clutch Lever towards front of printer to engage clutch.
- g. Press TOP OF FORM pushbutton to advance tape loop to the programmed top-of-form channel.

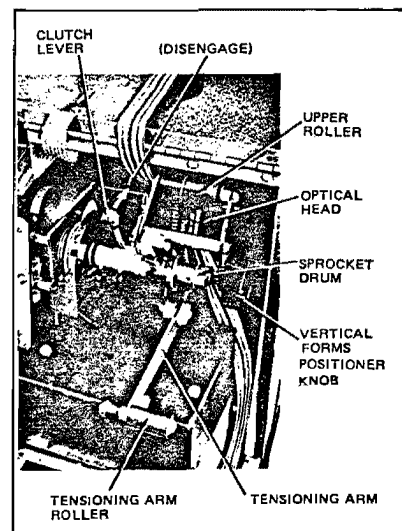

Figure 2

(continued)

FORMS LENGTH SELECTOR/MECHANICAL VFU OPTIONS

LOADING PAPER

UNLOADING PAPER

CHANGING RIBBON/CLEANING

UNPACKING THE PRINTER/INSTALLING THE PRINTER

CONFIGURING THE PRINTER/FUNCTIONAL CHECKS

INTRODUCTION

LOADING MECHANICAL VFU

(continued)

- h. Move Clutch Lever towards rear of printer to disengage clutch.
- i. Rotate Vertical Forms Positioning Knob to position paper so that first printing line is aligned with TOP OF FORM mark on paper tractor.
- j. Raise Clutch Lever towards front of printer to engage clutch.
- k. Close printer cover.

Note that the TOP OF FORM light is on when a program tape is installed on the mechanical VFU. Note also that the CHECK light is on when the clutch is disengaged.

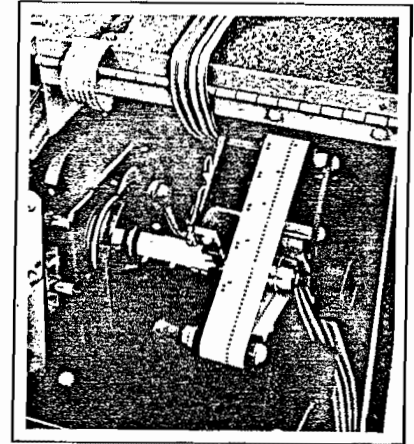

Figure 3

LOADING PAPER

Locate the fanfold paper stack under the printer and in line with the loading slot near the front edge of the printer bottom. Then load the printer by performing the following steps (figure 4 identifies controls used in loading and adjusting paper in the printer):

- a. Open front cover.
- b. Lift Forms Thickness Adjustment Lever (figure 5) to "Load" position (fully raised to move platen away from ribbon and hammer bank).
- c. Insert top edge of paper through slot in printer bottom and pass it past the print station until it can be grasped by the fingers above the print station.
- d. Open the tractor gate on each paper tractor to expose the feed pins.
- e. Raise paper to the tractors, keeping paper vertical (figure 6). If sprocket holes in paper do not match the distance between tractor feed pins, loosen knurled nuts on tractors and slide tractors sideways as

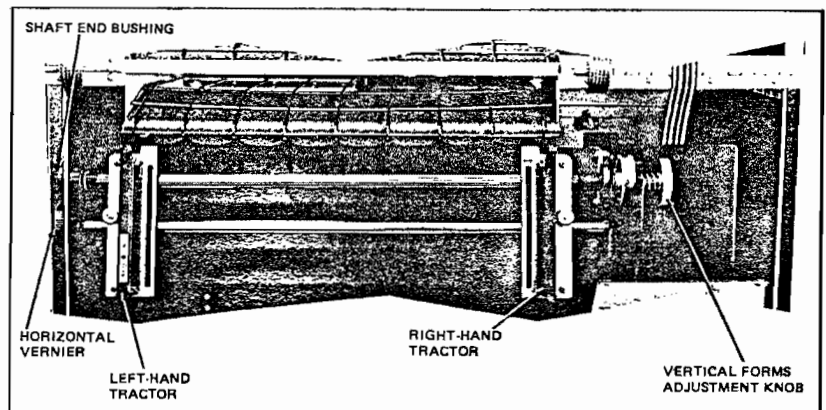

Figure 4

necessary to match holes to pins, then close gate on each tractor. Position paper and tractors so that the first character position on the paper scale falls in approximately the desired first-column position on the paper.

- f. Adjust tractors to provide very slight tension across the form. Too much tension

may distort sprocket holes in the paper and cause problems in paper feeding. When paper is correctly positioned and tensioned, lock knurled nuts on paper tractors. Note that the Horizontal Vernier may be adjusted at any time to position the first character at the correct location in the form (within a 3-character range).

(continued)

LOADING PAPER

UNLOADING PAPER

CHANGING RIBBON/CLEANING

UNPACKING THE PRINTER/INSTALLING THE PRINTER

CONFIGURING THE PRINTER/FUNCTIONAL CHECKS

LOADING PAPER (continued)

g. If power is not on, turn-on power to the printer, then press TOP OF FORM pushbutton.

h. Use the Vertical Forms Positioner Knob (figure 7) to set the space for the first printing line opposite the TOP OF FORM mark on the left-hand tractor (figure 5).

i. Align reference mark on the Vertical Forms Positioner Disk with the fixed pointer, then rotate the Vertical Forms Positioner Knob exactly one revolution to lower the paper and leave the paper reference mark again aligned with the fixed pointer. This locates the top-of-form line on the paper at the print station.

j. Grasp the paper at both sides below the paper entrance and pull lightly downwards to make the paper taut in the printer.

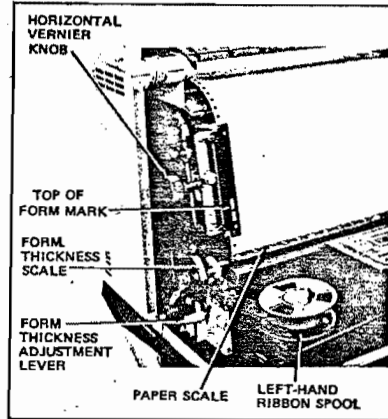

Figure 5

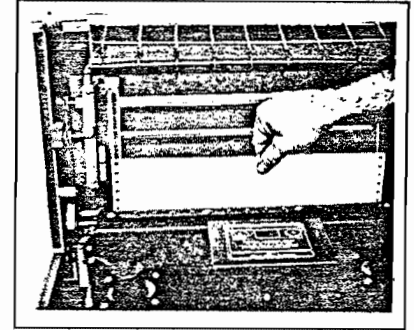

Figure 6

k. Move Forms Thickness Adjustment Lever downwards to the position suitable for the paper or form in the printer. Position depends on the number of parts and paper weight but, generally, set to position 3 for 3-part forms, etc. CHECK indicator should be off.

NOTE

If Forms Thickness Adjustment Lever is accidentally left positioned incorrectly for the thickness of the form, data may not be printed.

This completes paper loading. Prepare printer for on-line operation following steps outlined in *Operating Procedures*.

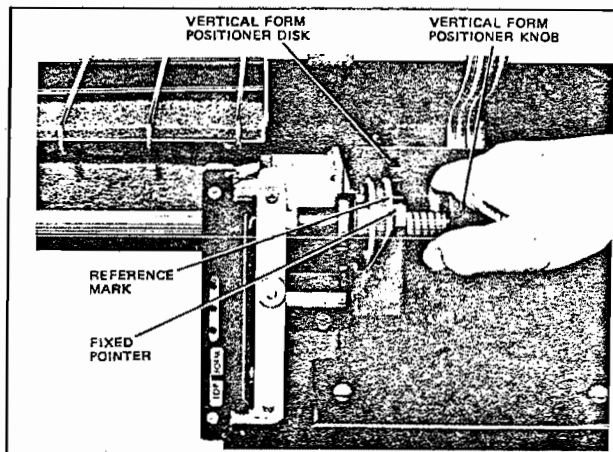

Figure 7

UNLOADING PAPER

To unload paper, proceed as follows:

a. Open paper gates on tractors, and pull paper forward to clear sprocket pins.

b. Move Forms Thickness Adjustment Lever to its fully raised position. Paper should drop freely down through the paper entrance. If paper does not fall freely from the printer, carefully check and clear any obstruction, and then guide paper carefully downwards through the paper entrance if necessary.

UNLOADING PAPER

CHANGING RIBBON/CLEANING

UNPACKING THE PRINTER/INSTALLING THE PRINTER

CONFIGURING THE PRINTER/FUNCTIONAL CHECKS

CHANGING RIBBON

To change the ribbon, proceed as follows:

- a. Open front cover.
- b. Remove paper from printer (refer to *Unloading Paper*).
- c. Unlock both ribbon spools by pulling latches toward center of hubs, and then lift spools from hubs, clearing loose ribbon from the guides and ribbon slot. Discard used ribbon and spools.
- d. Check for any build-up of ribbon chaff around guides and clean if necessary, wiping with a soft cloth.
- e. Install new ribbon spools on the hubs with ribbon running off the spools as shown in the decal on the ribbon assembly.

f. Run ribbon over the ribbon guides and across the front of the shuttle as shown in the decal on the ribbon assembly (figure 8).

g. Rotate either spool to take up slack, and make sure the ribbon runs smoothly over the guides. A twisted ribbon will cause missing characters, shorten ribbon life, and create paper jams.

h. The new ribbon is now ready for use, after paper is loaded and the Forms Thickness Adjustment Lever is set to the correct position for form thickness.

NOTE

Ribbon life will be extended if ribbons are inverted periodically.

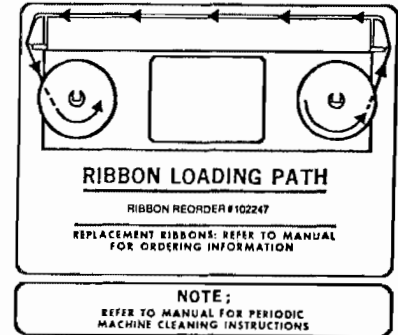

Figure 8

CLEANING

Perform general cleaning procedures at intervals of approximately three months, or after approximately 250 hours of operation. More dusty environments may require more frequent cleaning.

Clean the cabinet using a soft cloth and mild detergent. Clean the interior of the printer using a soft brush and vacuum, paying particular attention to areas with accumulated paper dust or ribbon chaff.

Check air filter under the ribbon assembly (figure 9) and clean it with vacuum if it appears clogged with dirt. If the filter is heavily clogged, your service representative must remove the filter for further cleaning.

If printing quality deteriorates or there is other evidence of need for further cleaning or other maintenance, call your service representative.

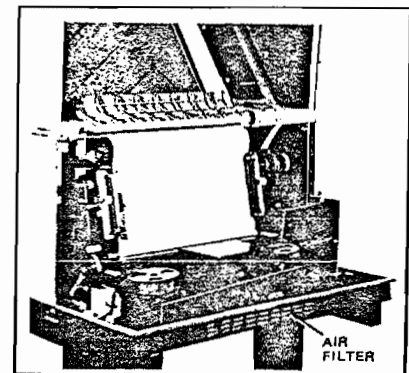

Figure 9

UNPACKING THE PRINTER

The printer is packaged in a corrugated paper carton, strapped to a wood pallet. Gross weight is 220 pounds. Transport the package to the installation site before unpacking, then unpack as follows (figure 10):

- a. Cut bands that hold carton to pallet.
- b. Gently tip carton off of pallet, tipping towards the FRONT side of carton, then inverting carton so that TOP rests on the floor (figure 10a).
- c. Carefully cut paper tape that seals bottom of carton (now on the top), being careful not to cut deeper than the carton flaps.
- d. Open carton flaps fully to expose inner carton (figure 10b).
- e. Rotate pallet 90 degrees so that board ends face the carton (figure 10b).
- f. Remove the four form packing blocks at corners of the inner carton.
- g. Tip carton up and back so that FRONT is on top, then continue to tip carton back until inner carton rests on pallet (figure 10c).
- h. Lift outer carton from inner carton, then remove four remaining foam packing blocks from inner carton. Set aside pack-

ing blocks and outer carton for future re-shipping.

- i. Remove and set aside shipping kit on top of inner carton (figure 10d).
- j. Tip inner carton up and off the pallet so that FRONT of carton rests on the floor (figure 10e).
- k. Carefully cut paper tape that seals back of carton (now on the top), being careful not to cut deeper than the carton flaps.

l. Open carton flaps fully to expose back side of printer, then remove plastic film wrapper from around printer.

m. Tip carton up and back onto pallet so that open side of carton rests on pallet (figure 10f), then lift off carton and set aside for future reshipping.

n. Remove the two cardboard pads from bottom of printer, then carefully tip printer so that it rests in its normal operating position (figure 10g).

o. Lift printer onto pedestal or onto table prepared for it. Note that rubber feet must be removed before printer can be installed on pedestal.

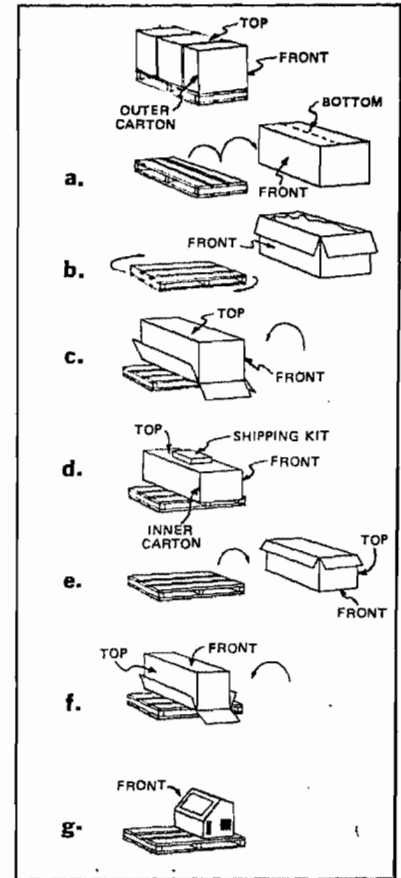

Figure 10

INSTALLING THE PRINTER

The printer is normally installed on the matching pedestal (optional). To mount the printer on the pedestal, assemble pedestal and then install the printer, performing the following steps.

- a. Assemble pedestal legs to modesty panel, and install glides following assembly instructions furnished with pedestal.
- b. Lay printer on its rear surface to expose printer bottom (use cardboard on floor to protect printer finish).
- c. Remove the four rubber feet from the printer bottom, using a Phillips screwdriver.

d. Locate the four threaded holes in printer bottom that did not retain the rubber feet removed in step c. These holes will receive screws that hold the printer to the pedestal (figure 11). Run 10-32 screws or tap into each of these holes to clear paint residue from threads.

e. Raise printer and rest it on pedestal, aligning holes prepared in step d. with matching holes in top bars of pedestal (figure 11).

(continued)

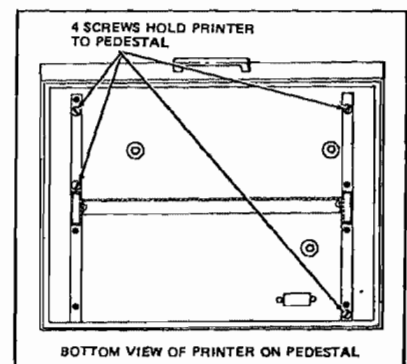

Figure 11

INSTALLING THE PRINTER (continued)

f. Secure printer to pedestal using the four 10-32 x 5/8-inch screws furnished with the pedestal.

g. Using a 9/16-inch wrench, adjust pedestal glides until printer is leveled (so that the printer front cover opens and closes evenly and easily).

h. Open front cover, then cut and remove cable tie that holds Forms Thickness Adjustment Lever in the "Load" position (protects platen during shipment).

i. Place paper catcher (wire basket) on floor between pedestal feet, with one end against left-hand base of pedestal (figure 12).

j. Install ground wire between printer and paper catcher as follows:

1. Remove screw and washer that hold ac connector to rear of printer (figure 13a), install quick-disconnect terminal (supplied) on screw, and retighten screw in rear of printer.

2. Connect quick-disconnect end of ground wire (furnished) to terminal installed in preceding step.

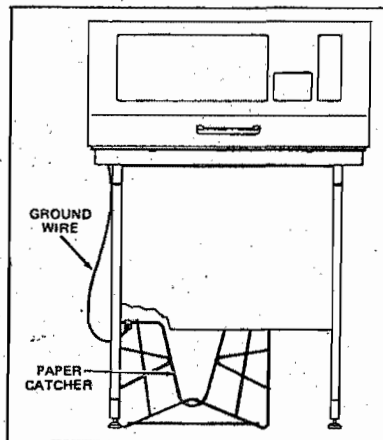

Figure 12

3. Assemble other end of wire (with ring terminal) to clamp, lockwasher, screw, and nut (figure 13b) with clamp gripping larger wire on paper catcher.

k. Connect the ac power cable, and the interface cable, to mating connectors on the rear of the printer.

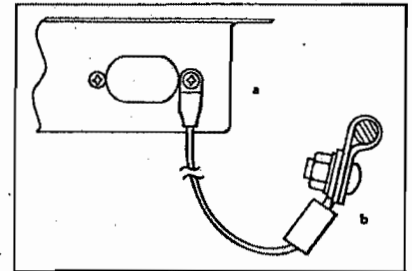

Figure 13

CONFIGURING THE PRINTER

The printer should be configured for the application by the service representative. He will install jumpers, termination resistors, and optional character memory devices to fit the printer exactly for the application.

Information for configuration is contained in the *Applications Manual*.

After configuration is completed, perform procedures outlined in *Functional Checks*.

FUNCTIONAL CHECKS

To perform a general check of printer operation, proceed as follows:

- Close front cover.
- Set AC power switch to the on position, then verify that the POWER indicator is lighted.
- Set AC power switch to off position.
- Load paper and ribbon as described in *Operating Instructions* in this manual.
- Set AC power switch to on position, then close front cover.
- Verify that CHECK indicator is off, and that the TOP OF FORM indicator is off (TOP OF FORM is lighted only if the Electronic VFU has been loaded or if a tape has been installed on a Mechanical VFU, or if the printer contains the Forms

Length Selector option).

If CHECK is lighted, press to reset. If CHECK remains lighted check correct paper loading. If CHECK condition persists, notify maintenance personnel.

g. Press TOP OF FORM pushbutton and see that the paper advances to top of the next form.

h. Press 8LPI pushbutton and see that the pushbutton lights. If initial printing is to be spaced at 8LPI, leave pushbutton lighted.

i. Press ON LINE pushbutton. Pushbutton should light indicating that the printer is able to receive data. The Electronic VFU may now be loaded (if used), and data received for printing.