

PRICE \$2.00

HEATHKIT®
OPERATIONAL MANUAL



EDUCATIONAL ELECTRONIC
ANALOG COMPUTER

MODEL EC-1

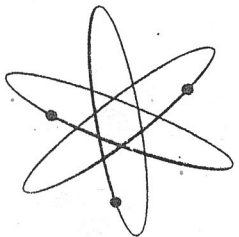

HEATH COMPANY • BENTON HARBOR, MICHIGAN

RESISTOR AND CAPACITOR COLOR CODES

RESISTORS

The colored bands around the body of a color coded resistor represent its value in ohms. These colored bands are grouped toward one end of the resistor body. Starting with this end of the resistor, the first band represents the first digit of the resistance value; the second band represents the second digit; the third band represents the number by which the first two digits are multiplied. A fourth band of gold or silver represents a tolerance of $\pm 5\%$ or $\pm 10\%$ respectively. The absence of a fourth band indicates a tolerance of $\pm 20\%$.

CODE			
COLOR	1ST DIGIT	2ND DIGIT	MULTIPLIER
BLACK	0	0	1
BROWN	1	1	10
RED	2	2	100
ORANGE	3	3	1,000
YELLOW	4	4	10,000
GREEN	5	5	100,000
BLUE	6	6	1,000,000
VIOLET	7	7	10,000,000
GRAY	8	8	100,000,000
WHITE	9	9	1,000,000,000
GOLD	-	-	.1
SILVER	-	-	.01

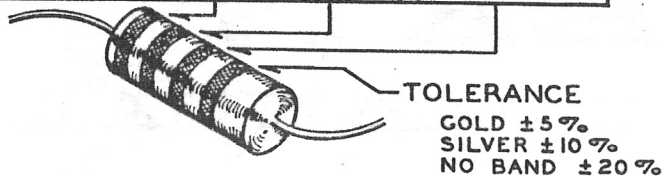

The physical size of a composition resistor is related to its wattage rating. Size increases progressively as the wattage rating is increased. The diameters of 1/2 watt, 1 watt and 2 watt resistors are approximately 1/8", 1/4" and 5/16", respectively.

The color code chart and examples which follow provide the information required to identify color coded resistors.

EXAMPLES

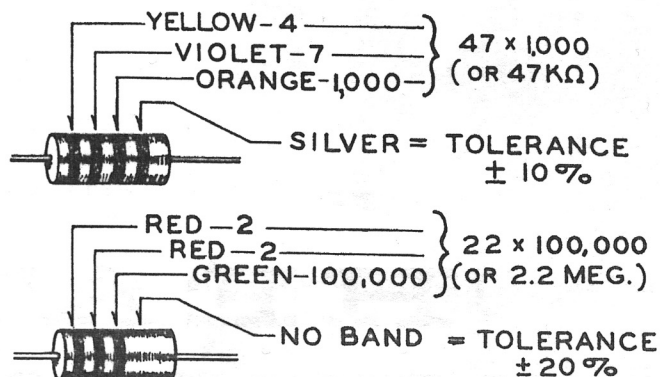

CAPACITORS

Generally, only mica and tubular ceramic capacitors, used in modern equipment, are color coded. The color codes differ somewhat among capacitor manufacturers, however the codes

shown below apply to practically all of the mica and tubular ceramic capacitors that are in common use. These codes comply with EIA (Electronics Industries Association) Standards.

MICA

CODE				TOLER. %
COLOR	1ST DIGIT	2ND DIGIT	MULTIPLIER	
BLACK	0	0	1	± 20
BROWN	1	1	10	± 20
RED	2	2	100	± 2
ORANGE	3	3	1,000	± 3
YELLOW	4	4	10,000	—
GREEN	5	5	—	± 5
BLUE	6	6	—	—
VIOLET	7	7	—	—
GRAY	8	8	—	—
WHITE	9	9	—	—
GOLD	-	-	.1	—
SILVER	-	-	.01	± 10

EXAMPLE

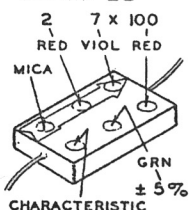

$2700\mu\text{f} \pm 5\%$
 OR $.0027\mu\text{f}$

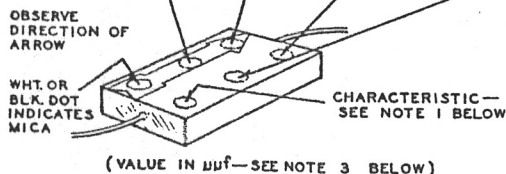

TUBULAR CERAMIC

Place the group of rings or dots to the left and read from left to right.

CODE				TOLER. %	
COLOR	1ST DIGIT	2ND DIGIT	MULTIPLIER	OR LESS OVER 10	OR LESS OVER 10
BLACK	0	0	1	± 20	± 20
BROWN	1	1	10	± 0.1	± 1
RED	2	2	100	—	± 2
ORANGE	3	3	1,000	—	± 2.5
YELLOW	4	4	10,000	—	—
GREEN	5	5	—	± 0.5	± 5
BLUE	6	6	—	—	—
VIOLET	7	7	—	—	—
GRAY	8	8	—	± 0.25	—
WHITE	9	9	—	± 1.0	± 10

EXAMPLE

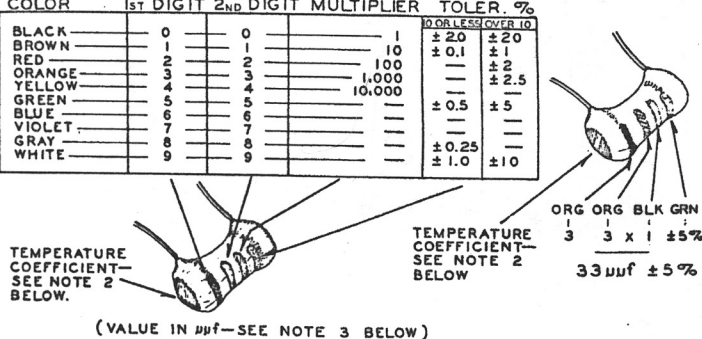

NOTES:

- The characteristic of a mica capacitor is the temperature coefficient, drift capacitance and insulation resistance. This information is not usually needed to identify a capacitor but, if desired, it can be obtained by referring to EIA Standard, RS-153 (a Standard of Electronic Industries Association).
- The temperature coefficient of a capacitor is the predictable change in capacitance with temperature change and is

expressed in parts per million per degree centigrade. Refer to EIA Standard, RS-198 (a Standard of Electronic Industries Association.)

3. The farad is the basic unit of capacitance, however capacitor values are generally expressed in terms of μf (microfarad, .000001 farad) and $\mu\mu\text{f}$ (micro-micro-farad, .000001 μf); therefore, $1,000\mu\mu\text{f} = .001\mu\text{f}$, $1,000,000\mu\mu\text{f} = 1\mu\text{f}$. The designation pf is sometimes used for $\mu\mu\text{f}$.

USING A PLASTIC NUT STARTER

A plastic nut starter offers a convenient method of starting the most used sizes: 3/16" and 1/4" (3-48 and 6-32). When the correct end is pushed down over a nut, the pliable tool conforms to the shape of the nut and the nut is gently held while it is being picked up and started on the screw. The tool should only be used to start the nut.

6-32

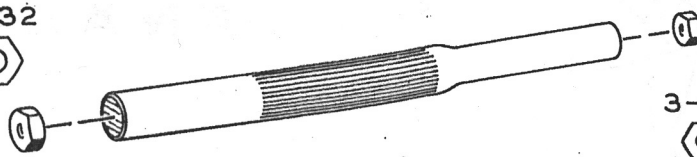

3-48



OPERATIONAL MANUAL FOR THE HEATH EDUCATIONAL ANALOG COMPUTER MODEL EC-1



PREFACE

The purpose of this manual is threefold: first, to present, in elementary form, the fundamental mathematical theory of analog computers; second, to provide instructions for operation of the Heath Educational Analog Computer; and third, to show some illustrative examples of problems which can be solved on the Computer.

This manual is not intended to be exhaustive but rather to be a guide in the operation of the computer. For this reason frequent references are made to the available literature. Several excellent books as well as many articles are available. Some of these are listed in the references at the end of the manual. These should be available to and used by anyone with a serious interest in analog computers.

CONTENTS

Preface	1
Introduction	3
Theory	4
Circuit Description	
DC Operational Amplifier	13
Amplifier Power Supply	14
Initial Condition Power Supplies	15
Control Circuit	15
Repetitive Oscillator	15
General Operating Instructions	16
Basic Mathematical Operations	
Addition	17
Multiplication	19
Integration	19
Illustrative Problems	
Falling Body	21
Spring-Mass System	24
Simultaneous Algebraic Equations	26
Projectile	27
Bouncing Ball	28
References	31
Specifications	32
Parts List	36
Schematic	40

INTRODUCTION

One of the wonders of the modern Electronic Age is the computer or "Giant Brain", as it is sometimes called. Actually, the computer is not a "Brain" at all, since it does not think but must be "told" what to do. It is capable of doing mathematical operations at much greater speed and with greater accuracy than human beings.

A computer is a machine which performs physical operations that can be described by mathematical operations. In general, computers may be classified as digital or analog. Digital computers operate by discrete steps, that is, they actually count. Common examples of digital computers are the abacus, desk calculator, punched-card machine, and the modern electronic digital computer. The fundamental operations performed by the digital computer are usually addition and subtraction. Multiplication, for example, is accomplished by repeated additions.

Analog computers operate continuously, that is, they measure. Examples of analog computers are the slide rule (which measures lengths), the mechanical differential analyzer, the electro-mechanical analog computer and the all-electronic analog computer. The last three generally measure electrical voltages or shaft rotations. Physical quantities such as weight, temperature or area are represented by voltages. Voltage is the electrical analog of the variable being analyzed. Arbitrary scale factors are set up to relate the voltages in the computer to the variables in the problem being solved. For example, 1 volt equals 5 feet or 10 volts equals 1 pound. The name "analog" comes from the fact that the computer solves by analogy by using physical quantities to represent numbers.

The fact that the analog computer operates continuously makes it very useful in such operations as integration; for this reason computers used this way are sometimes known as Differential Analyzers.

One of the most powerful applications of analog computers is simulation in which physical properties, not easily varied, are represented by voltages which are easily varied. Thus the "knee action" of an automobile front wheel suspension can be simulated on an analog computer in which the weight of the automobile, the constant of the spring, the damping of the shock absorber, the nature of the road surface, the tire pressure and other conditions can be represented by voltages. In practice these factors cannot be readily changed, but on the computer any one or all of these may be varied at will and the results observed as the changes are made.

Analog computers are especially useful in solving dynamic problems in which the motion can be expressed in the form of a differential equation.

All mathematical operations necessary to the solution of ordinary differential equations can be built up from addition, multiplication by a constant, and integration.* As will be shown later, the analog computer can perform these operations and thus is a convenient device for the solution of differential equations.

The combination of the six basic computer operations will perform any continuous function. Some of the types of problems which can be solved by these methods are radioactive decay, chemical reaction, beam oscillation and heat flow. With the addition of crystal diodes and relays, simulation of discontinuous functions is possible. This makes possible solution of problems involving saturation, backlash, hysteresis, friction, limit stops, vacuum tube characteristics, and different modes of operation such as sonic vs. subsonic flow.

* Shannon, C., JOURNAL MATH. AND PHYSICS, Vol. 20, Pages 337-354, 1941.

With the addition of special devices such as function generator and function multiplier, additional operations may be performed such as multiplication of variables, computation of trigonometric, exponential and logarithmic functions and generation of discontinuous functions.*

THEORY

In order to solve differential equations on an analog computer, it is necessary to have:

1. DC amplifiers (also called operational amplifiers) capable of performing the operation of
 - a. Integration
 - b. Addition (or summation)
 - c. Multiplication by a constant
 - d. Multiplication by -1 (inversion)
2. A means of setting coefficients in a problem. This may be done by means of
 - a. Potentiometers
 - b. Changing the ratio of feedback resistance to input resistance.
3. A control system for starting and stopping solution of the problem, as well as resetting the initial conditions so as to be ready for running a new solution with the same or new coefficients and initial conditions.

The general procedure in solving a problem is to:

1. Set the machine variables (voltages) to the correct initial conditions.
2. Make the computing elements operative and force the voltages to vary in the manner prescribed by the differential equations.
3. Observe and/or record the voltage variations, with respect to time, which constitute the solution of the given problem.
4. Stop the machine and reset for a new run.

The heart of the analog computer is the DC operational amplifier which performs the basic mathematical operations necessary for the solution of problems.

The amplifier used in the analog computer is a high gain direct-coupled amplifier with negative feedback and is represented by a triangle with the base at the input end and the apex at the output end, as shown in Figure 1.

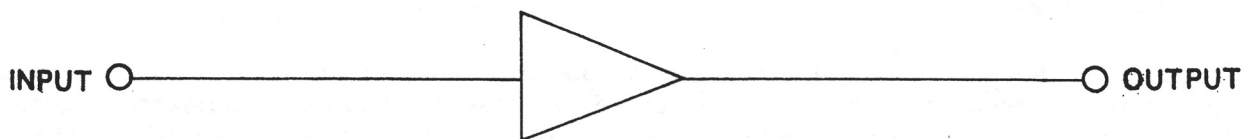

Figure 1

AMPLIFIER SYMBOL

* Clarence L. Johnson, ANALOG COMPUTER TECHNIQUES (McGraw-Hill Book Company, Inc., New York 1956) Chapter 8, Pages 136-164.
Korn and Korn, ELECTRONIC ANALOG COMPUTERS (McGraw-Hill Book Company, Inc., New York 1956) Second Edition, Chapter 6, Pages 251-344.

In use, resistors and capacitors are connected as input and feedback elements in such a way as to perform various mathematical operations. For use as a multiplier, resistors are used as input and feedback elements, as shown in Figure 2.

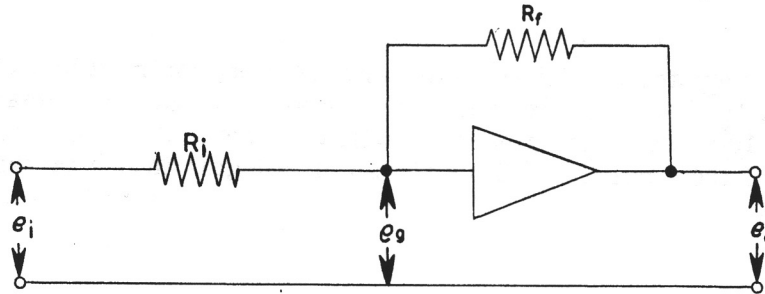

Figure 2

AMPLIFIER AS MULTIPLIER AND INVERTER

In this Figure, e_i represents the input voltage, e_g the grid voltage, e_o the output voltage, R_i the input resistor and R_f the feedback resistor.

The gain of an amplifier is given by

$$A = -\frac{e_o}{e_g}$$

On solving for e_g , the expression

$$e_g = -\frac{e_o}{A} \quad \text{is obtained.}$$

From this it can be seen that e_g approaches zero as A approaches infinity. In practice, A is made large with respect to e_o by using high gain amplifiers so that e_g becomes very small, and for practical purposes e_g can be considered to be at ground potential.

Since the input to the amplifier is the grid of a tube, the current through the amplifier from the input can be considered to be zero, with the result that the current i_i through the resistor R_i is, for all practical purposes, equal to the current i_f through the resistor R_f , with the result that

$$\frac{e_i}{R_i} \cong -\frac{e_o}{R_f} \quad \text{since} \quad i = \frac{e}{R} \quad \left(\text{The symbol } \cong \text{ means "approximately equal to"} \right)$$

which becomes

$$e_o \cong -\frac{R_f}{R_i} e_i \quad *$$

*For a more rigorous approach, see Korn and Korn, ELECTRONIC ANALOG COMPUTERS (McGraw-Hill Book Company, Inc., New York, 1956), Second Edition, Page 12.

The approximation which results from considering $e_g = 0$ will be used in the further discussion of the DC amplifier but the "approximately equal to" sign will not be used, that is, i_i will be considered to be equal to i_f .

In practice, the gain of DC computer amplifiers will vary from approximately 1000 for repetitive computers to as high as 10^6 for a large commercial installation. Since the maximum output of an amplifier is generally 100 volts, the value of e_g will vary from about 0.1 volt to 1 microvolt, depending on the gain of the amplifier. Thus the amplifier gain is one factor in the accuracy of an analog computer.

The equation

$$e_o = -\frac{R_f}{R_i} e_i$$

may be written

$$e_o = -K e_i \quad \text{where} \quad K = \frac{R_f}{R_i}$$

which is, in effect, multiplication by a constant. Since, in most cases, the output voltage is of the opposite sign to the input voltage, the amplifier also acts as an inverter or sign changer.

To change the value of the constant K, it is necessary only to change R_i or R_f . Generally, R_f is kept at 1 megohm and R_i is changed. This may be done by using a different value fixed resistor or by using a potentiometer as shown in Figure 3.

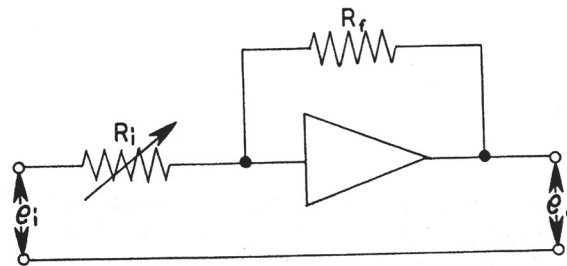

Figure 3

POTENTIOMETER AS INPUT RESISTOR

Another method of obtaining odd constant values of R_i is shown in Figure 4.

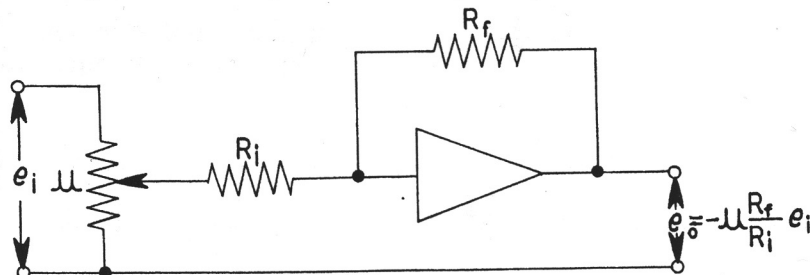

Figure 4

POTENTIOMETER AS INPUT RESISTOR

The input voltage e_i appears across a potentiometer (usually 100 K Ω), and a fraction μ of it is selected. The voltage e_o appearing across the output is then given by the expression

$$e_o = -\mu \frac{R_f}{R_i} e_i$$

Suppose, for example, a ratio of 3.7 is desired. If μ is made equal to 0.37 and $R_f/R_i = 10$ ($R_f = 1$ megohm and $R_i = 100$ K Ω), then $e_o = -3.7 e_i$. Generally this method is to be preferred over that shown in Figure 3.

In actual practice, the ratio R_f/R_i is generally greater than unity, since the amplifiers tend to become unstable for values less than unity. Also the ratio R_f/R_i is 100 or less, as values greater than 100 introduce inaccuracies in the solution of the problem.

If, instead of the one input resistor shown in Figure 2, two or more resistors are used as shown in Figure 5, the operational amplifier becomes an adder.

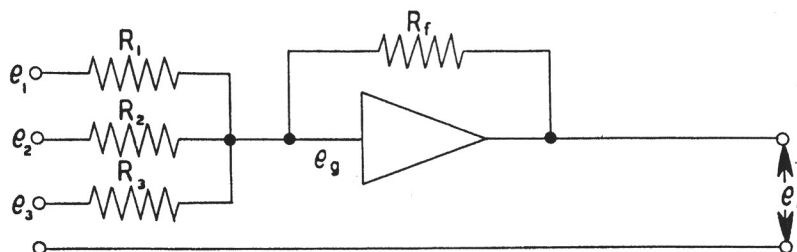

Figure 5

AMPLIFIER AS ADDER

Again making use of $e_g \cong 0$, the sum of the currents in the input resistors equals the current through the feedback resistor.

Thus
$$i_1 + i_2 + i_3 = i_f$$

But, since $i = \frac{e}{R}$ it follows that

$$\frac{e_1}{R_1} + \frac{e_2}{R_2} + \frac{e_3}{R_3} = -\frac{e_o}{R_f}$$

Multiplication of both sides of the equation by R_f gives the result

$$e_1 \frac{R_f}{R_1} + e_2 \frac{R_f}{R_2} + e_3 \frac{R_f}{R_3} = -e_o$$

which can be written

$$e_o = -(K_1 e_1 + K_2 e_2 + K_3 e_3)$$

where

$$K_1 = \frac{R_f}{R_1}, \quad K_2 = \frac{R_f}{R_2}, \quad K_3 = \frac{R_f}{R_3}$$

The operational amplifier can thus be used to add and at the same time multiply any of its inputs by constants. Any number of inputs can be used as long as the output voltage does not exceed the nominal range of the amplifier.

Since subtraction can be considered to be the addition of negative numbers, subtraction can be performed by using negative voltages for those quantities to be subtracted. The circuit shown in Figure 6 would give the result

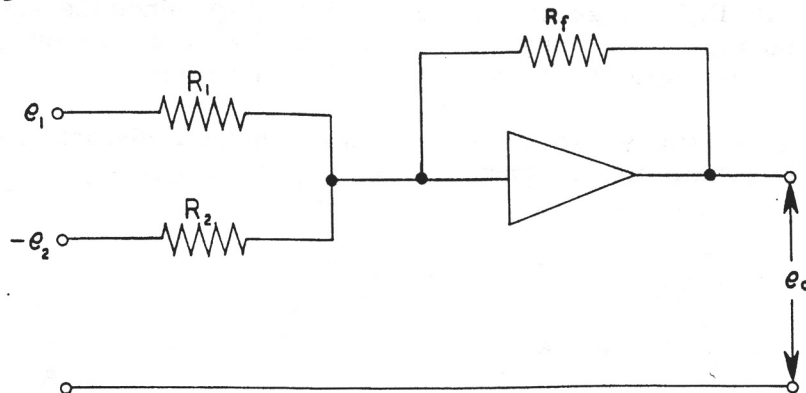

Figure 6

OPERATIONAL AMPLIFIER CIRCUIT USED FOR SUBTRACTION

$$e_o = - \left(\frac{R_f}{R_1} e_1 - \frac{R_f}{R_2} e_2 \right)$$

which may be written

$$e_o = - (K_1 e_1 - K_2 e_2)$$

where

$$K_1 = \frac{R_f}{R_1} \quad \text{and} \quad K_2 = \frac{R_f}{R_2}$$

Division can be performed by multiplying by the reciprocal of the number, but since this sometimes requires a ratio of R_f/R_i of less than unity, which may cause unstable operation of the amplifier, this method is generally undesirable. The circuit shown in Figure 7 shows a more desirable method.

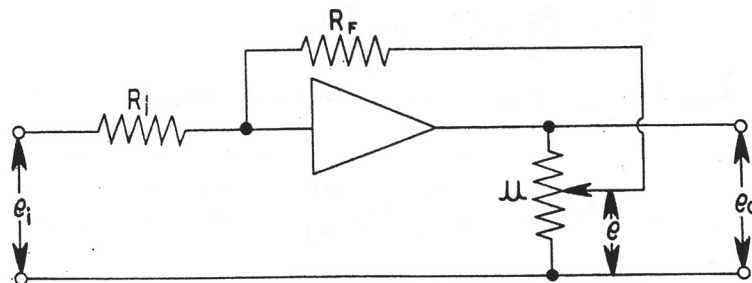

Figure 7

DIVISION BY A CONSTANT

The voltage e is given by $e = - \frac{R_f}{R_i} e_i$

It is also given by $e = \mu e_o$

where μ is the ratio of the voltage e_o appearing across the potentiometer to the voltage across the arm of the potentiometer and ground.

$$\text{Thus } \mu e_o = -\frac{R_f}{R_i} e_i$$

$$\text{and } e_o = -\frac{1}{\mu} \frac{R_f}{R_i} e_i$$

Thus division by μ has been accomplished if R_f/R_i is made unity ($R_f = R_i = 1$ megohm, for example).

Since μ is less than unity, a scale factor must be introduced when dividing by numbers larger than one. Let the desired divisor be 2.5. The value chosen for μ would then be 0.25, since μ is less than one. The indicated result (answer) will then be greater by a factor of 10 than the true value of the answer, so the indicated answer must be divided by the same value as used in reducing the division to a value of less than one (in this case 10). Thus, for this example

$$e_o = -\frac{1}{0.25} \left(\frac{1}{10}\right) \frac{R_f}{R_i} e_i$$

$$\text{since } 2.5 = 0.25 \times 10$$

choosing $R_f = R_i = 1 \text{ MEG}$, this becomes

$$e_o = -\frac{1}{0.25} \left(\frac{1}{10}\right) e_i$$

$$\text{which becomes } 10 e_o = -\frac{1}{0.25} e_i$$

If the divisor had been 25, a factor of 100 would have been chosen, yielding

$$100 e_o = -\frac{1}{0.25} e_i$$

and the indicated result would be divided by 100. If the division is less than unity, no correction is necessary.

Again making use of the approximation $e_g \approx 0$, it is possible to show the operation of the amplifier as an integrator. The feedback resistor is replaced by a capacitor, as shown in Figure 8 on Page 10.

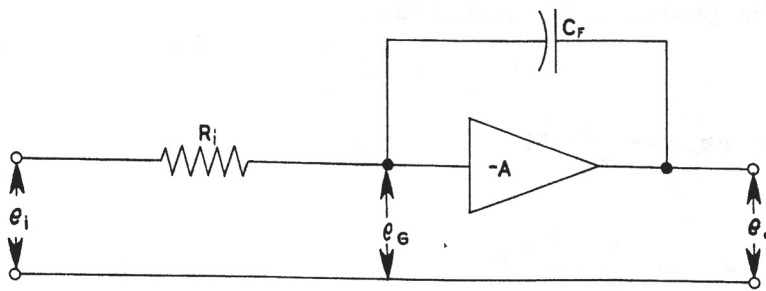

Figure 8

OPERATIONAL AMPLIFIER AS INTEGRATOR

$$\frac{e_i}{R_i} = i = \frac{dQ}{dt}$$

Since $dQ = c_f de_o$ this becomes

$$\frac{e_i}{R_i} = -c_f \frac{de_o}{dt}$$

Solving this equation for de_o gives the result

$$de_o = -\frac{1}{R_i c_f} e_i dt$$

Integration of both sides gives

$$e_o = -\frac{1}{R_i c_f} \int e_i dt + e_{ic}$$

Where e_{ic} is the constant of integration (initial condition) and is the voltage across the capacitor c_f at time $t = 0$. Thus the operational amplifier can integrate.

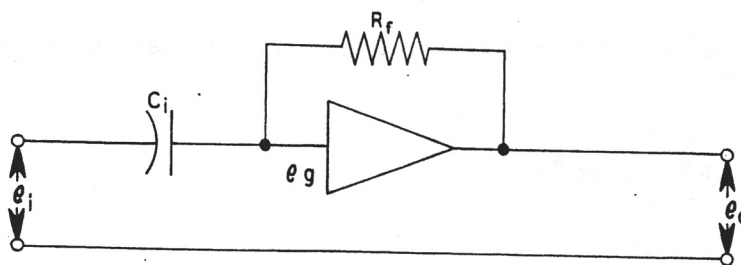

Figure 9

AMPLIFIER AS DIFFERENTIATOR

It is possible to show, by a similar analysis, that the operational amplifier can be used to differentiate. The amplifier is used very seldom for this purpose, however, since noise in the input tends to be magnified by differentiation, whereas it tends to cancel out in integration. Such circuits also tend to be unstable.

In practice, the value of the feedback resistor R_f , when used, is generally 1 megohm and the value of the feedback capacitor c_f , when used, is generally 1 μ fd. The value of the input resistor usually varies from 0.1 megohm to 1.0 megohm, although in certain problems the values may be different from these values.

A combination of simple operations forms a complex operation. In general, an analog computer is not used for addition alone or for multiplication by a constant as a single operation. These can be better performed by other means. The value of the computer lies in its ability to combine these simple operations into a complex operation.

An example of a complex operation is indicated by the circuit shown in Figure 10.

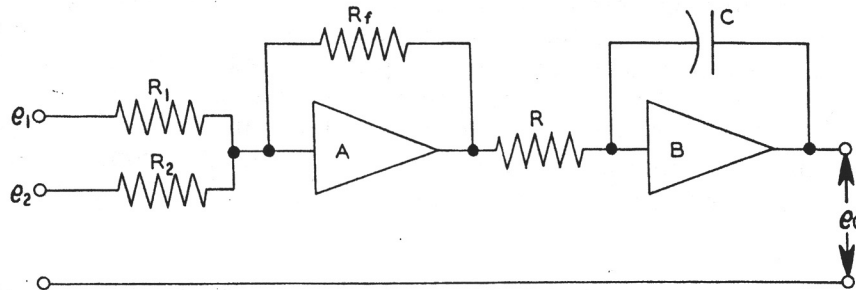

Figure 10

COMPLEX OPERATION

This circuit solves the relationship

$$e_o = \frac{1}{RC} \int_0^t \left[\frac{R_f}{R_1} e_1 + \frac{R_f}{R_2} e_2 \right] dt + e_o(0)$$

where $e_o(0)$ is the output voltage at time $t = 0$ (start of problem solution). Amplifier A is used for sign inversion. It can be omitted if a minus result is acceptable.

Another example of a simple type of problem involving complex operation is that of an object falling due to the force of gravity. The acceleration which the body experiences is constant near the surface of the earth and due to the force exerted on the object by the gravitational field of the earth. This may be written as an equation,

$$\frac{d^2 y}{dt^2} = g$$

where y is the distance the object falls in time t , and g is the acceleration given the object by the earth's gravitational field. By integrating twice, it is possible to obtain an expression for y in terms of g and the time t during which the body has fallen. This can easily be set up on the computer, using two amplifiers as shown in Figure 11.

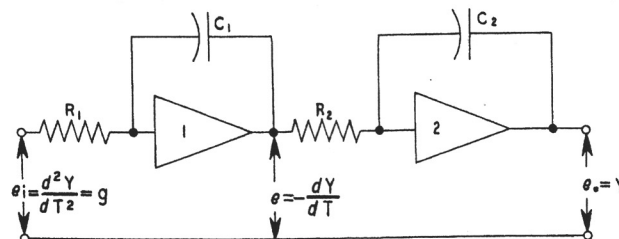

Figure 11

AMPLIFIER CONNECTIONS FOR SOLVING "FALLING BODY PROBLEM"

The input voltage e_i is supplied by a suitable power supply and the value of e_i is chosen so that e_o does not exceed the output capacity of amplifier 2. Instructions for setting up this problem are given on Page 21. It is suggested, however, that the actual setup and solution of the problem be withheld until the CIRCUIT DESCRIPTION and OPERATION sections of this manual have been thoroughly reviewed and are generally understood.

Other examples of the application of complex operation to the solution of problems are given in the section on OPERATION.

SCALE FACTORS

In the operation of the analog computer two factors must be considered. The first of these is the amplitude factor. In general, the output of each amplifier must be kept within the range ± 100 volts, the actual value depending on the amplifier used in the computer. In order to keep the output within the specified limits, it is generally necessary to scale down the input voltages. It is not always possible to determine before hand the range of the voltages, in which case a trial run can be made and after the voltages are observed, the proper amplitude scale factors can be chosen. Sometimes it is possible to estimate the range of voltages from the physics of the problem.

The other factor is time. If the product $R_i C_f = 1$ when R_i is measured in ohms and C_f is measured in farads, the computation is said to be in real time. This is so, for example, when $R_i = 1$ megohm and $C_f = 1 \mu\text{fd}$. ($R_i C_f = 10^6 \text{ ohms} \times 10^{-6} \text{ farad} = 1$) If the computer is operated such that the solution is obtained in less time than is required for the physical solution to occur, the operation is said to be faster than real time. This is very useful if the physical occurrence which is being simulated requires considerable time. Time is also saved, permitting the solution of more problems in the same length of machine time.

Another advantage is that machine error is decreased, especially the error due to the leakage resistance of the feedback capacitors. In general, the solution of a problem on the computer should not require more than 1 to 5 minutes. Longer solution times require special precautions.*

REPETITIVE OPERATION

It is desirable, for many problems, to repeat the solution and observe the effect on the solution of changing the various parameters of the problem. This is made possible by repetitive operation. Some means is provided for automatically resetting the computer and re-running the problem. A cathode ray oscilloscope is convenient for observing the solution in this case. Generally, one of the computer amplifiers is used to provide the sweep for the oscilloscope. Details of operation will be discussed in the section on OPERATION.

ACCURACY

As was shown previously, the higher the amplifier gain the less will be the error in each computing operation. Thus the accuracy depends in part on the gain of the operational amplifier. Accuracy also depends on the precision of the computing components, such as resistors and capacitors. Time is also a factor in accuracy. In general, long runs introduce errors due to amplifier drift and capacitor leakage.

* Goode and Machol, SYSTEM ENGINEERING (McGraw-Hill Book Company, Inc., New York, 1957), Pages 278-283.

Clarence L. Johnson, ANALOG COMPUTER TECHNIQUES (McGraw-Hill Book Company, Inc., New York, 1956), Chapter 3, Pages 20-44.

Korn and Korn, ELECTRONIC ANALOG COMPUTERS (McGraw-Hill Book Company, Inc., New York, 1956), Pages 30-35.

James B. Resnick, "Scale Factors for Analog Computers", Product Engineering, March, 1954.

Any variations in voltages in any part of the circuit of a direct-coupled amplifier cause variations in the output voltage which in turn introduce errors in the solution. With constant input the output will vary, resulting in "drift", which increases with amplifier gain. This introduces a paradox since, as has been shown, error is reduced by increasing amplifier gain but this in turn increases drift which increases errors. For this reason, very high gain amplifiers generally use some means of stabilization in order to reduce drift.*

READ-OUT

For arithmetic problems in which a single numerical answer is obtained, the result can be read on the meter. In problems having a continuous solution (changing with time) an oscilloscope is desirable. It is possible in this case to watch the effect on the solution of varying the various problem parameters. This is especially true when repetitive operation is used. In this case one of the computer amplifiers is used to provide the sweep. The oscilloscope must be a DC scope.

If a permanent record of the solution is desired, a photograph of the oscilloscope trace may be made or a recording galvanometer may be used. Examples of both methods are shown in the illustrative problems.

NON-LINEAR OPERATION

A discussion of non-linear operation is beyond the scope of this manual. An excellent treatment of non-linear operation can be found in ANALOG COMPUTER TECHNIQUES by Clarence L. Johnson, Chapter 7, Pages 107-127.

CIRCUIT DESCRIPTION

DC OPERATIONAL AMPLIFIER

The general requirements for a DC amplifier for computer use are high gain, high input impedance, low output impedance, good linearity and stability (low drift). The circuit of the amplifier used in the Heath Analog Computer is shown in Figure 12.

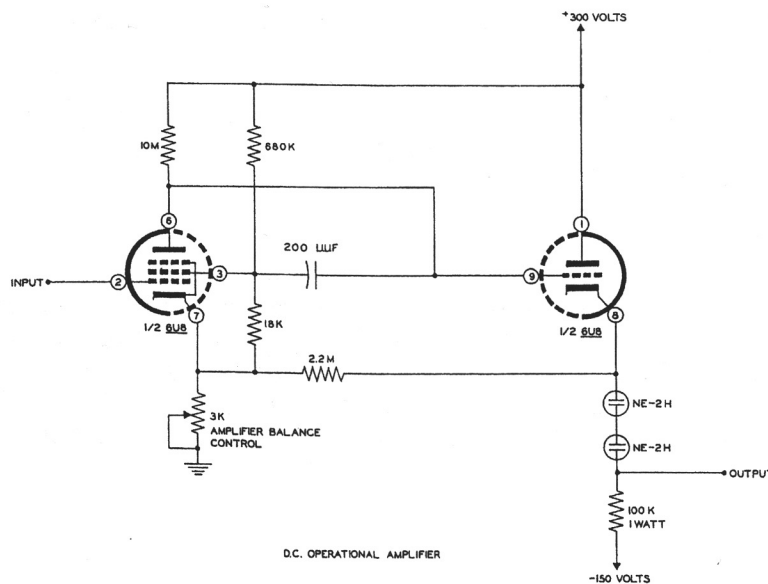

Figure 12

DC OPERATIONAL AMPLIFIER FOR EC-1

* Korn and Korn, ELECTRONIC ANALOG COMPUTERS (McGraw-Hill Book Company, Inc., New York, 1056) Second Edition, Pages 191-196 and 231-239.

The amplifier is designed around a 6U8 tube with which it is possible to achieve a gain of approximately 1000. This is adequate for the use for which this computer is designed. This high gain is achieved by operating the pentode section of the 6U8 with a large plate load and with low voltage on the screen grid.* This gives a gain of approximately 700. The gain is increased to approximately 1000 by adding a small amount of positive feedback. The 2.2 megohm resistor provides this feedback.

The 3 K Ω control is used for adjusting the output of the amplifier to zero volts when there is no input signal. One way of doing this (used in the EC-1) is to use a 1 megohm feedback resistor and a 1 megohm resistor between input and ground, as shown in Figure 13.

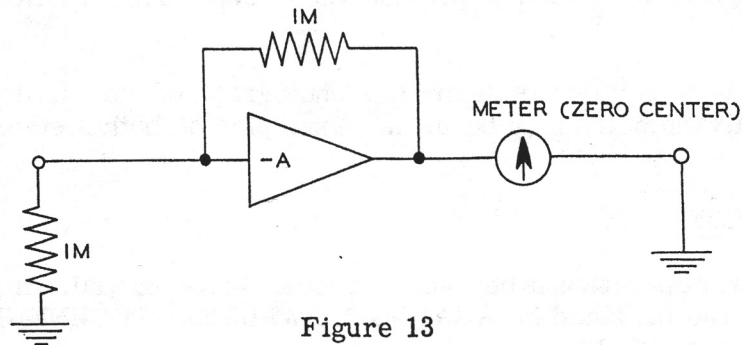

Figure 13

AMPLIFIER BALANCE DIAGRAM

With the amplifier set up as in Figure 13, the 3 K Ω zero adjust control is set for zero reading on the meter. In the EC-1, this is accomplished by merely operating a switch to its BALANCE position, which disconnects the amplifier from the problem board and connects the proper feedback and input resistors, thus simplifying the balancing operation.

The triode section of the 6U8 is connected as a cathode follower output stage. The two NE-2H neon lamps are used as a reference voltage dropping element by which the output signal level can be dropped from approximately 112 volts to zero volts without loss in gain, as would occur if a purely resistive element were used.

The input and output terminals of the amplifier are on the panel or problem board with two of each provided. These are so arranged that plug-in units may be easily and rapidly used to change impedance values for various problems.

AMPLIFIER POWER SUPPLY

The +300 volt power supply is a conventional electronically regulated unit which provides the +300 volts for operation of the amplifiers. The 250 K Ω control adjusts the output voltage over a range of approximately +250 to +350 volts. The circuit is shown in Figure 14. Provision is made for using the meter on the panel for setting the voltage to +300 volts. The -150 volts DC required by the amplifier is supplied by a half-wave rectifier, the output of which is controlled by an OA2 regulator tube.

* George E. Kaufer, "How to Design Starved Amplifiers", Tele-Tech and Electronic Industries, Vol. 14, No. 1, January 1955, Page 68.

Walter K. Volkens, "Ultra-High-Gain Direct-Coupled Amplifier Circuits", - paper read before 1950 IRE National Convention in New York.

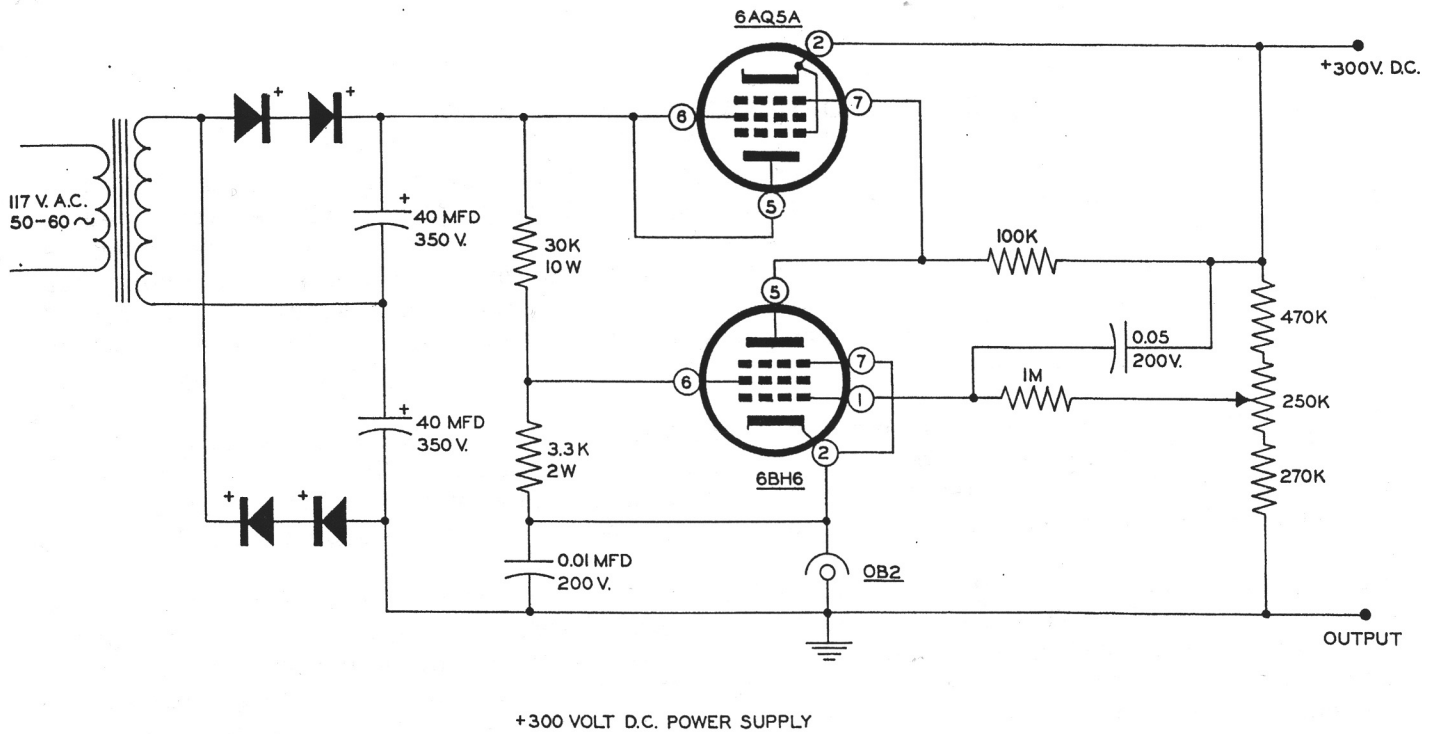

Figure 14

+300 VOLT DC POWER SUPPLY FOR EC-1

INITIAL CONDITION POWER SUPPLIES

The voltages for the initial conditions or the "given" quantities of the problem are supplied by three initial condition power supplies. These use conventional half-wave rectifiers with OB2 regulator tubes and potentiometers so that any voltage from 0-100 may be obtained. The supplies are ungrounded, making them usable for either plus or minus voltages with respect to amplifier ground.

CONTROL CIRCUIT

While the amplifiers perform the actual mathematical operations, it is necessary to provide certain control functions. Before solution of the problem can commence, the voltage of the amplifier must be set to the proper value and the amplifiers must be balanced. Provision is made for this by means of a meter and a FUNCTION switch on the panel. By use of the FUNCTION switch and meter, the output of any of the operational amplifiers may also be measured. An OPERATION switch turns the computer on, starting solution of the problem. After the problem is solved, it is necessary to reset the computer to the starting conditions. This is accomplished by setting the OPERATION switch to the RESET position, which operates a relay which in turn removes residual voltages from the amplifiers and resets initial condition voltages so that the computer is ready to again solve the problem.

REPETITIVE OSCILLATOR

Sometimes it is desirable to automatically repeat the solution a number of times. This is accomplished in the EC-1 by means of a multivibrator which cycles the relay at an adjustable rate of from approximately 0.1 to 15 times per second. In this way the effect on the solution of changing any of the problem parameters may be observed. The rate of repetition is changed by a control on the panel.

GENERAL OPERATING INSTRUCTIONS

Electrical power for the computer is controlled by two toggle switches marked FILAMENT and HIGH VOLTAGE, with green and clear pilot lamps, respectively. These switches are wired so that the filaments may be on with the high voltage off, but the high voltage will not be on unless the filament switch is in the ON position. Thus the filaments may be left on when the computer is not in actual use, doing away with the warming-up time otherwise necessary. The filaments should be turned on several minutes (preferably at least one-half hour) before use and should then be left on unless the computer is to be idle for a period of several hours or longer.

To adjust the amplifier power supply output, the METER FUNCTION switch is set to SET B+. The OPERATION switch should be in the RESET position. With the HIGH VOLTAGE switch ON, turn the control VC on the chassis (near the rear) until the meter pointer rests at the red mark labeled SET B+. This sets the output of the amplifier power supply to +300 volts.

Leaving the OPERATION switch in the RESET position, set the METER RANGE switch to 100 V and the METER FUNCTION switch to AMPLIFIER BALANCE. Starting with amplifier 1, press downward the slide switch immediately below the amplifier terminals on the panel and, using a screwdriver, turn the AMPLIFIER BALANCE CONTROL until the meter pointer reads zero. Repeat this operation for each of the other eight amplifiers. With the METER RANGE switch set at 10 V, repeat the above operation for each amplifier. Once again, repeat the above operation for each amplifier with the METER RANGE switch set at 1 V. The amplifiers should be checked for balance before each problem run. It is not necessary to remove computing components from the problem board when balancing amplifiers as the slide switch on the panel disconnects the amplifier from the problem board, as shown in Figure 15.

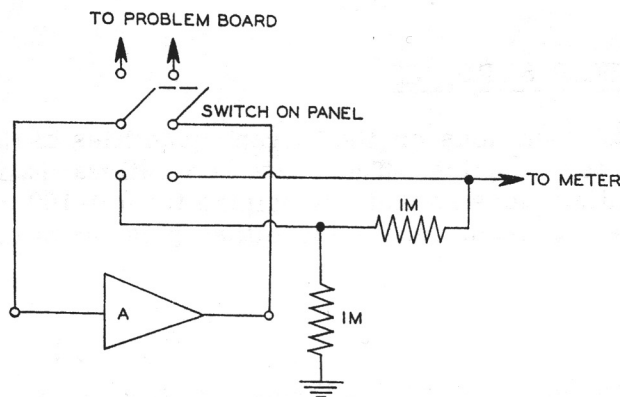

Figure 15
AMPLIFIER BALANCE CIRCUIT

Two binding posts above and to the right of the meter provide for external use of the meter. With the METER FUNCTION switch in INPUT position, the meter is disconnected from the computer and connected to the two binding posts labeled METER INPUT. The meter may then be used to measure voltages of 100 or less applied to the METER INPUT binding posts. The METER RANGE switch is used to select the proper range. The meter has a sensitivity of 10,000 ohms per volt.

The AMPLIFIER OUTPUT binding posts above and to the left of the meter provide for external read-out, such as with an oscilloscope or pen recorder. By turning the METER FUNCTION switch to any of the positions 1 through 9, the output of the corresponding amplifier may be read on the meter or taken off at the terminals marked AMPLIFIER OUTPUT. If desired, the METER RANGE switch may be set to OFF, thus disconnecting the meter from the output circuit and using only the binding posts. The AMPLIFIER OUTPUT terminals are automatically disconnected

from the meter when the METER FUNCTION switch is at SET B+ or INPUT, making it unnecessary to disconnect the external read-out unit when checking the power supply voltage. Likewise, the METER INPUT terminals are disconnected at all positions of the METER FUNCTION switch except INPUT.

The outputs of the three initial condition power supplies are connected to binding posts on the panel immediately under the controls for the supplies. The outputs are not grounded, making it possible to use either the plus (red) or minus (black) terminal for the "hot" terminal. Since the supplies are not grounded, it is necessary to ground one of the terminals of each supply in use. The output is zero when the control is full counterclockwise; turning the control clockwise increases the output up to 105 volts, with a maximum current of 5 ma.

Five coefficient potentiometers are provided on the panel. One end terminal is grounded, with the other end terminal and the center terminal connected to binding posts on the panel. The center terminal of the control (black binding post) is grounded when the control is in full counterclockwise position. The ungrounded end terminal (red binding post) will be connected to the IC supply voltage of the required potential.

A 4PST relay is used for inserting initial conditions and for removing residual voltages from the amplifiers. For convenience, the connections to the relay contacts are brought to binding posts on the panel where they may be connected across problem components as required. The relay contacts are normally closed. Turning the OPERATION switch to MANUAL will start solution of a problem by opening the relay contacts, which will remain open until the switch is returned to RESET. Setting the OPERATION switch to REPETITIVE will connect the relay to the repetitive oscillator, opening and closing the contacts at a rate determined by the REPETITION RATE control on the panel. Turning the control clockwise increases the rate of operation from the minimum of approximately 0.1 cps to the maximum of approximately 15 cps.

Computing components are connected to the amplifiers by means of 2-prong plugs inserted into sockets on the panel. Suggested methods of mounting components on the plugs are shown in Figure 25 in the Construction Manual.

BASIC MATHEMATICAL OPERATIONS

ADDITION

Two quantities can be added by feeding two voltages, proportional to the quantities, into an amplifier, as shown in Figure 16.

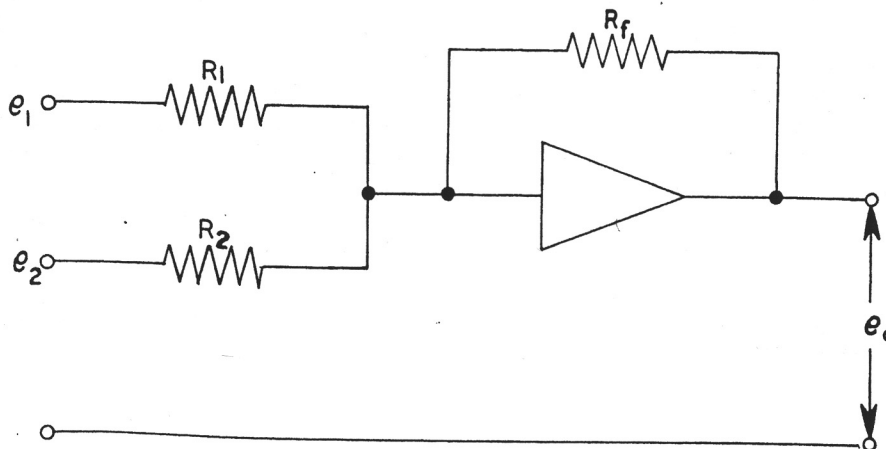

Figure 16

AMPLIFIER USED FOR ADDITION

As an example, consider the simple problem of finding the sum of $36 + 58$. Since the sum of these numbers is greater than 60, the voltages used cannot be equal to the numbers but must be scaled down. In this case, voltages equal to $1/10$ of the numbers will be suitable. The problem setup now looks like Figure 17.

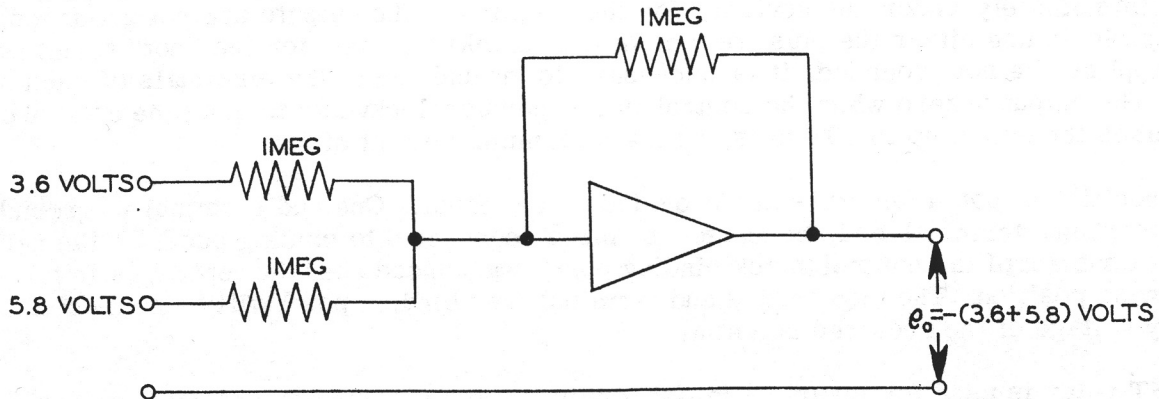

Figure 17

AMPLIFIER USED FOR ADDITION

Since the input voltages are equal to $1/10$ of the quantities being added, the output voltage will be $1/10$ of the sum and so must be multiplied by 10 to obtain the answer. Notice that the answer is negative with respect to the inputs. If this is undesirable, a second amplifier may be used for sign inversion. See Figure 18.

The voltages are obtained from the initial condition power supplies and the answer is read on the meter. Turn on the FILAMENT switch, after having plugged 1 megohm 1% precision resistors, previously mounted on 2-prong plugs, into the two input sockets and the feedback socket of amplifier 1. Plug in a patch cord between the black binding post of initial condition power supply 1 and the black binding post marked METER INPUT which is above the meter. Connect another patch cord from the red binding post of IC-1 (initial condition power supplies will hereafter be called IC) and the red binding post marked METER INPUT. Set the METER FUNCTION switch at 10 V and the number 1 INITIAL CONDITION control to extreme counterclockwise position. Turn on the HIGH VOLTAGE switch and turn the IC-1 control clockwise until the meter reads 3.6 volts. Now unplug the end of the patch cord at the red METER INPUT binding post and plug it into either of the INPUT binding posts of amplifier 1. In the same manner, connect IC-2 to the meter (connect the black binding post of IC-2 to the black binding post marked METER INPUT) and set the control IC-2 so the meter reads 5.8 volts. Unplug the end of the patch cord at the red METER INPUT binding post and plug it into the other INPUT binding post of amplifier 1. Set the METER FUNCTION switch to AMPLIFIER OUTPUT 1 and read the voltage on the meter. Multiply this reading by 10 to obtain the answer. CAUTION: In general, before using the meter for reading an answer, the METER RANGE switch should be on the 100 V range so as not to damage the meter if the result exceeds 10 V. In this case, we knew the answer would be less than 10 V. Also remember that the output of any amplifier should not exceed ± 60 volts.

Since the red binding posts of the IC power supplies are connected to the amplifier inputs, the input voltages are positive (+).

The output read on the meter is negative (-) however, due to the action of the amplifier as an inverter or sign changer. A plus answer can be obtained by use of a second amplifier with unity gain ($R_i = R_f$, generally 1 megohm in each case). This is shown in Figure 18.

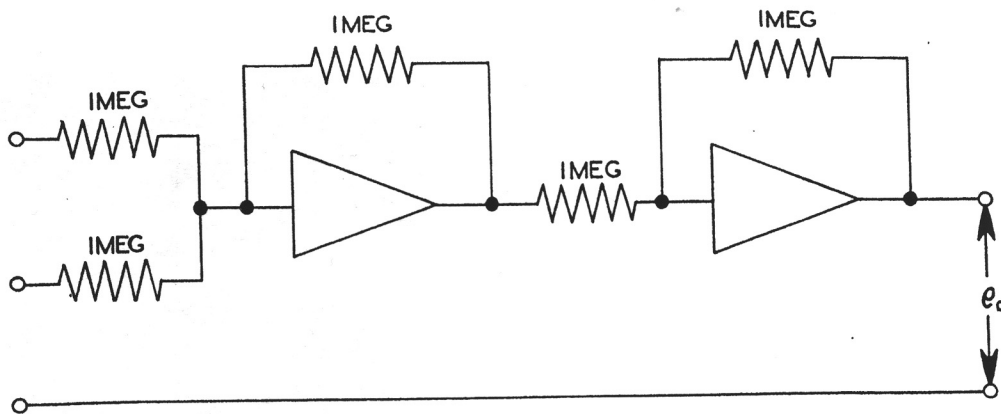

Figure 18

AMPLIFIERS USED FOR ADDITION AND INVERSION

MULTIPLICATION

Multiplication by a constant is performed by using different values of input resistor and feedback resistor. As an example, find the product of 10×37 . See Figure 19. Plug a 100 K, 1% precision resistor into either input socket and a 1 megohm resistor into the feedback socket of amplifier 1. Set IC-1 to 3.7 volts and then connect this voltage to that input of amplifier 1 to which the 100 K Ω resistor was connected. Read the output on the meter and multiply this reading by 10 to obtain the answer. (The 37 was divided by 10 in order to keep the result under 60 volts.) Again notice the result is negative with respect to the input, due to the 180 phase shift in the amplifier.

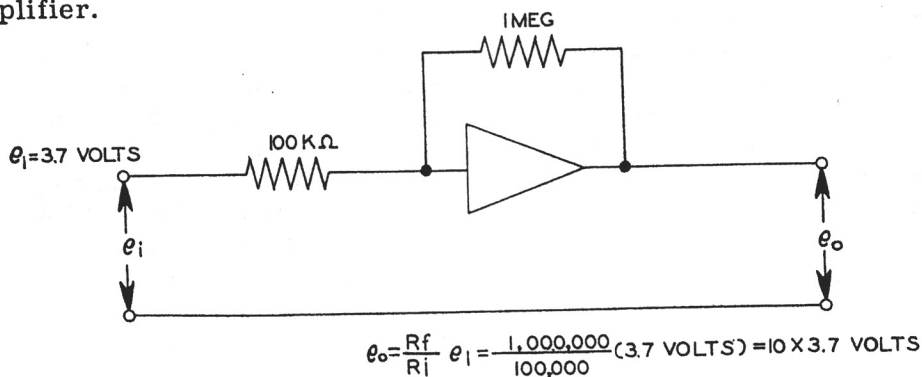

Figure 19

AMPLIFIER USED FOR MULTIPLICATION

INTEGRATION

It was shown on Page 10 that by replacing the feedback resistor of an amplifier with a capacitor, the output of the amplifier is proportional to the integral of the input voltage, or more specifically,

$$e_o = -\frac{1}{R_i c_f} \int e_i dt + e_{ic}$$

Plug a 1 megohm precision resistor into either of the input sockets and a 1 μ fd mylar capacitor into the feedback socket of amplifier 1. When using an amplifier as an integrator, it is necessary to remove the charge on the capacitor before using the amplifier again. If this is not done, an error will be introduced in the next solution due to this residual charge. In the EC-1, this is accomplished by connecting a pair of the relay contacts across the feedback capacitor; the contacts are closed when the amplifier is not integrating and open when the computer is operating, as shown in Figure 20 on Page 20.

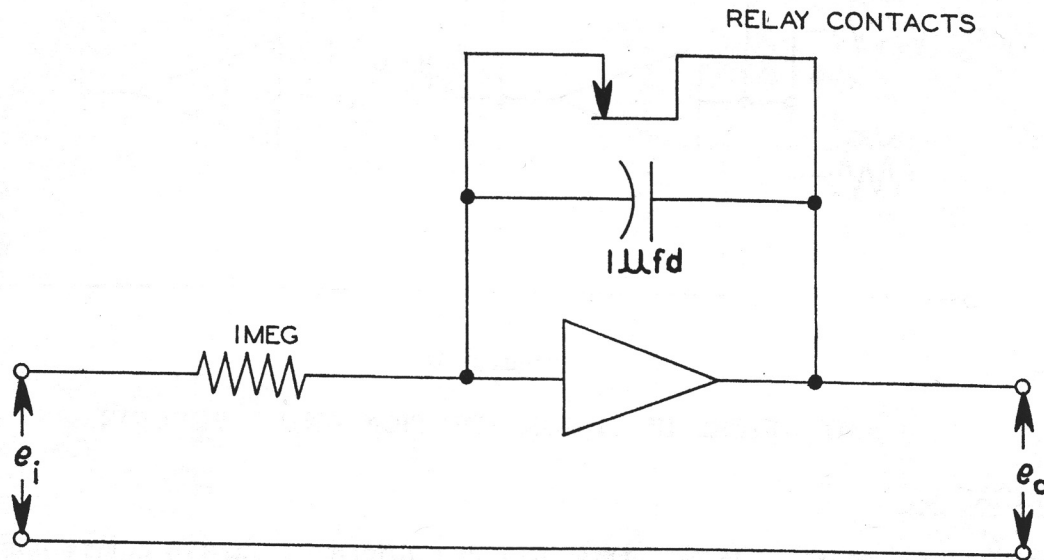

Figure 20

INTEGRATING AMPLIFIER WITH RELAY CONTACTS

When the OPERATION switch is in the RESET position, the relay contacts are all closed.

Connect the two binding posts on either end of the feedback socket to the two relay contacts 1, as shown in Figure 21. Set IC-1 to 5 volts and connect to the input of amplifier 1, to which the 1 megohm resistor was connected. Turn the OPERATION switch to MANUAL. The meter reading should increase rather uniformly from zero to approximately 100 V, but should be stopped at 60 volts by turning the OPERATION switch to RESET. This will stop integration and remove the charge from the capacitor, leaving it ready for operation again. Turning the OPERATION switch to REPETITIVE will start the computer operating, but now the oscillator will automatically reset the initial conditions and start solution again at a rate control by the REPETITION RATE control. This operation will continue until the OPERATE switch is returned to RESET.

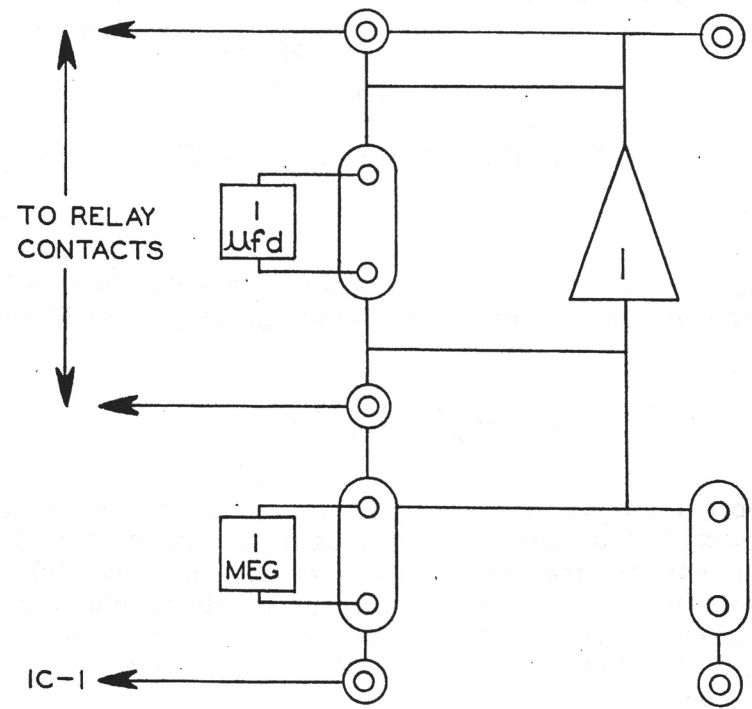

Figure 21

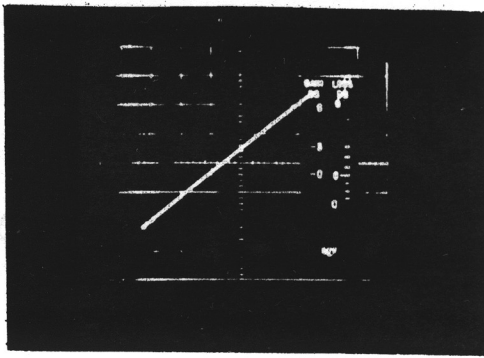

Figure 22A

(a) As observed on oscilloscope.

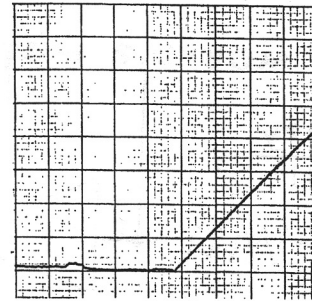

Figure 22 B

(b) As recorded by pen recorder.

OUTPUT VOLTAGE e_0 VS. TIME t FOR AMPLIFIER USED AS INTEGRATOR

The operations just carried out illustrate the basic operations performed by the computer, but the real value of the computer lies in combining these elementary operations in such a way as to solve problems.

ILLUSTRATIVE PROBLEMS

The operations just described are the basic operations which can be performed by the computer. They are given to illustrate the method of setup and operation rather than because they are useful in themselves. Only when the basic operations are combined for the solutions of complex problems does the computer become a valuable tool for problem solving.

The following problems will illustrate some of the types of problems, the solution of which can readily be obtained on the computer.

Components are furnished for use in solving some of these problems. For other problems, additional components are required. These may be standard radio components. Ordinary 5% or 10% resistors may be used where accuracy of results is not important, such as when only the general nature of the problem solution is needed.

Additional problems will be found in the references at the back of the manual.

FALLING BODY PROBLEM: One of the simplest problems encountered in elementary physics is that of a body moving under the influence of a constant force, such as the earth's gravitational field near the surface of the earth. The equation for the motion of a body in such a field is

$$\frac{d^2 y}{dt^2} = g$$

where g is the acceleration which a body experiences when in the earth's gravitational field and y is the distance the body falls in time t . To find the value of y , it is necessary to integrate twice.

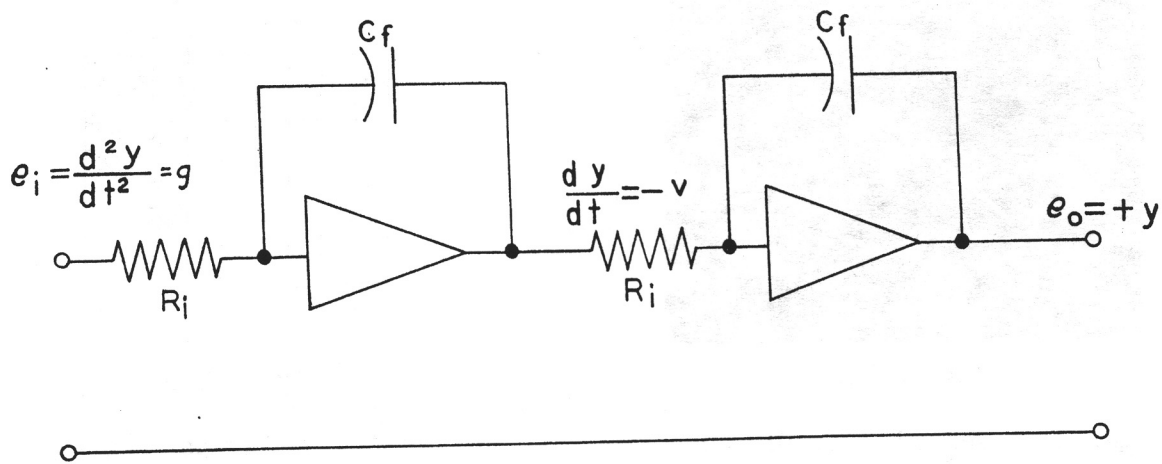

Figure 23

FALLING BODY PROBLEM CIRCUIT

The value of g is supplied by one of the IC power supplies. Some way must be provided for discharging the capacitors at the end of the solution of the problem. This can be accomplished by connecting the capacitor to the relay contacts which are open during solution of the problem and closed during the "reset" time.

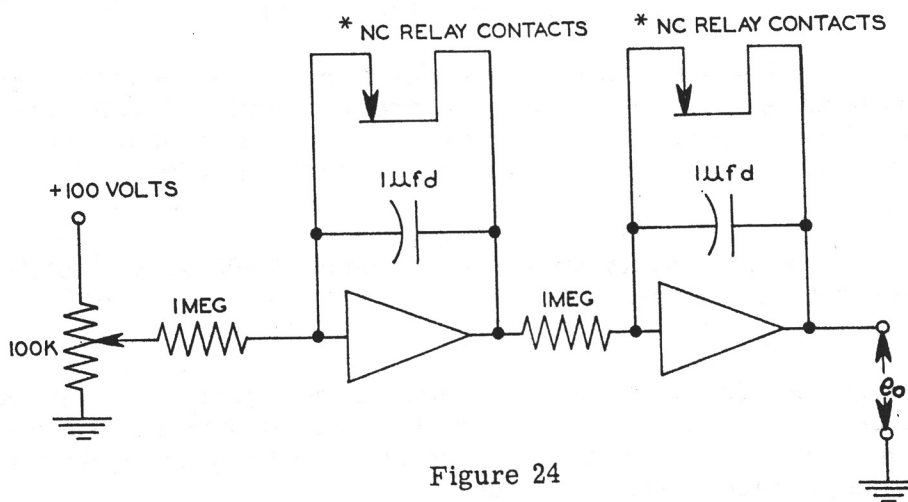

Figure 24

The 100 K potentiometer is the IC potentiometer. Connect a patch cord from the red binding post of IC-1 to the INPUT binding post of amplifier 1, and another patch cord from the black binding post of IC-1 to the black METER INPUT binding post above the meter. Plug a 1 megohm mounted resistor into the input socket of amplifier 1 (the one to which the patch cord is connected) and a 1 megohm resistor into either input socket of amplifier 2. Plug mounted $1 \mu\text{fd}$ capacitors into the feedback sockets of amplifiers 1 and 2. Connect a patch cord (short) from the output of amplifier 1 to the input of amplifier 2 (the one with the 1 megohm resistor). Connect patch cords from the AMPLIFIER INPUT binding post and AMPLIFIER OUTPUT binding posts to relay contacts 1 for amplifier 1 and relay contacts 2 for amplifier 2. Set IC-1 control to the first or second dot from the extreme counterclockwise direction. Set the METER RANGE switch to 100 V and the METER FUNCTION switch to AMPLIFIER OUTPUT 2. Turn the HIGH VOLTAGE switch to ON (the filament switch should previously have been turned to ON). Turn the OPERATION switch to MANUAL. The meter needle should move to the right, slowly at first, gaining speed as it moves. When the needle reaches 60-65 volts, turn the OPERATION switch to RESET which will discharge the capacitors, making the computer ready to again solve the problem. If the meter needle moves too slowly, turn the IC control clockwise; if the needle

* Normally closed.

moves too rapidly, turn the control counterclockwise. Turn the OPERATION switch to REPETITIVE. The computer will now reset itself and repeat the solution at a rate controlled by the REPETITION RATE control knob. This will continue until the OPERATION switch is returned to the RESET position. If a permanent record of the solution is desired, a pen recorder may be connected to the AMPLIFIER OUTPUT binding posts above the meter.

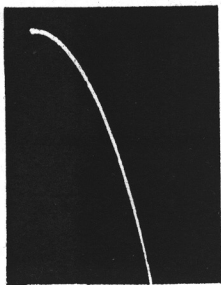

Figure 25 A

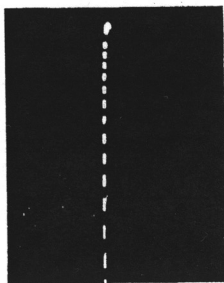

Figure 25 B

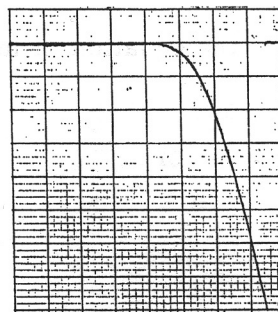

Figure 25 C

SOLUTION OF FALLING-BODY PROBLEM

- (a) As observed on oscilloscope. Body was given initial horizontal velocity.
- (b) As observed on oscilloscope (no initial horizontal velocity). The dashes represent equal time intervals, showing the increased distance traveled during each succeeding time interval.
- (c) As recorded on pen recorder.

The solution may be viewed on a DC oscilloscope, such as the Heath DC Oscilloscope, by connecting the vertical input of the oscilloscope to the red AMPLIFIER OUTPUT binding post and the ground to the black AMPLIFIER OUTPUT binding post. No sweep is needed to show the falling body, but if one wants to show the path when an initial horizontal velocity is given the body, a sweep voltage is necessary. To insure synchronization, one of the computer amplifiers should be used as the sweep generator for the oscilloscope, as shown in Figure 26.

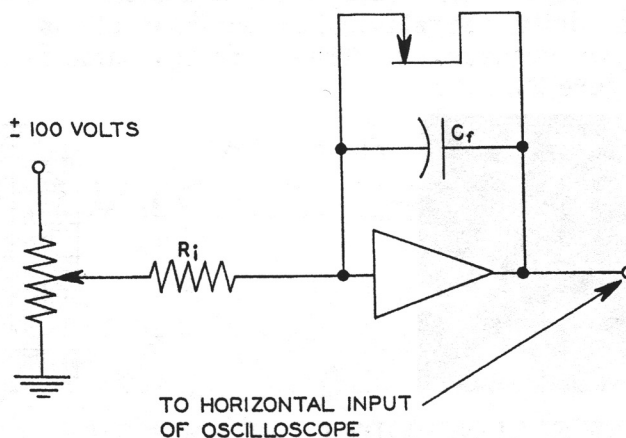

Figure 26

AMPLIFIER USED AS SWEEP GENERATOR

The ± 100 volts is obtained from one of the IC power supplies, using + or -, depending on the direction of sweep desired. Set the IC control until the desired rate of sweep is obtained. The values of R_i and of C_f should be the same as those used in the problem.

If a faster rate of solution is desired, the 1 megohm resistors should be replaced by 0.1 megohm resistors and the 1 μ fd capacitors by 0.1 μ fd capacitors, adjusting the REPETITION RATE control accordingly.

The previous problem considered the body to be falling without friction. If there exists a frictional force, proportional to the velocity $c \frac{dy}{dt}$

the equation of motion becomes

$$m \frac{d^2y}{dt^2} + c \frac{dy}{dt} + mg = 0$$

or

$$\frac{d^2y}{dt^2} = -g - \frac{c}{m} \frac{dy}{dt}$$

Handwritten notes:

$$y = \int v dt = \int \left(-g - \frac{c}{m} v \right) dt$$

$$y = -gt - \frac{c}{m} \int v dt$$

$$y = -gt - \frac{c}{m} y$$

$$\frac{dy}{dt} = -g - \frac{c}{m} y$$

$$\frac{dy}{y} = -\left(\frac{g}{v} + \frac{c}{m} \right) dt$$

The basic computer circuit is shown in Figure 27.

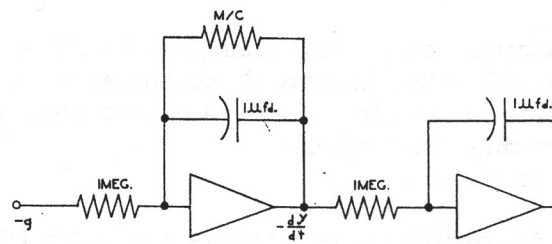

Figure 27

FALLING BODY PROBLEM CIRCUIT. FRICTIONAL FORCE ADDED.

This circuit is set up on the computer as before, with the addition of a feedback resistor across the first amplifier. For simplicity, the relay and ground connections are omitted as well as the initial condition power supply connections. These are the same as in the previous problem. The solution is shown in Figure 28.



Figure 28 A

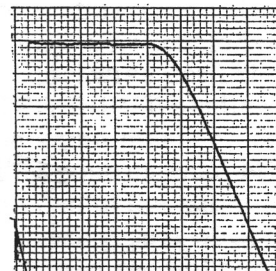

Figure 28 B

SOLUTION OF FALLING BODY PROBLEM WITH FRICTIONAL FORCE

(a) As displayed on oscilloscope.

(b) As shown on pen recorder.

SPRING-MASS SYSTEM

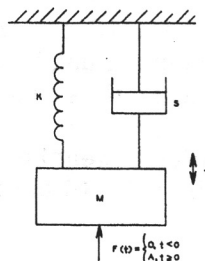

Figure 29

The differential equation of the spring-mass system shown in Figure 29 is

$$M \frac{d^2 y}{dt^2} + S \frac{dy}{dt} + Ky = F(t)$$

with $y(0) = \frac{dy}{dt}(0) = 0$.

The last expression states that the displacement at time equals zero (the start of the problem solution) $y(0)$ and the velocity at time equals zero $\frac{dy}{dt}(0)$ are both zero.

The differential equation may be written

$$M \frac{d^2 y}{dt^2} = F(t) - S \frac{dy}{dt} - Ky$$

The simplified computer diagram is shown in Figure 30.

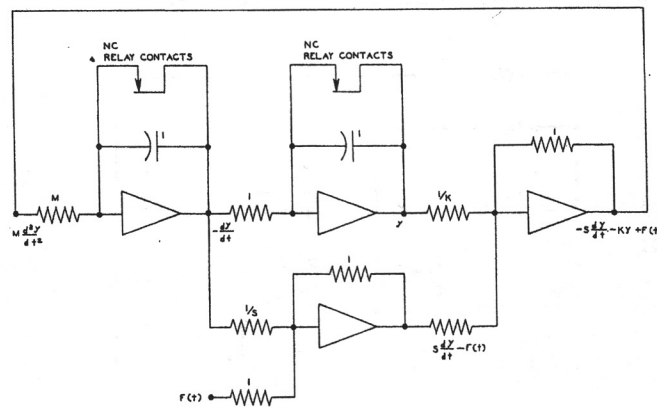

Figure 30.

SPRING-MASS SYSTEM CIRCUIT

In this diagram all resistor values are megohms and all capacitor values are microfarads. Ground connections are omitted for purpose of simplicity. $F(t)$ is supplied by one of the initial condition power supplies.

Various solutions are shown in Figure 31.

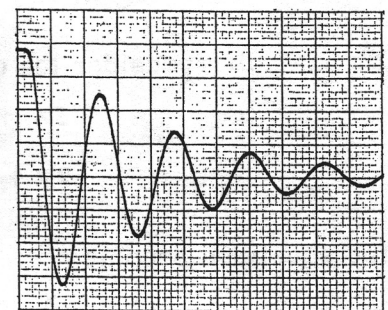
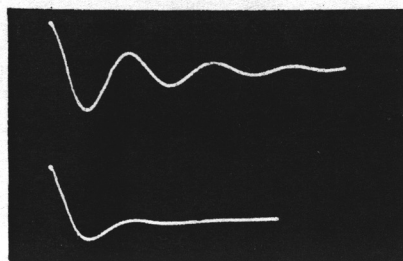
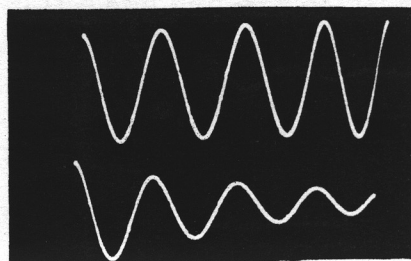

Figure 31

MASS, SPRING, DAMPER PROBLEM

SIMULTANEOUS ALGEBRAIC EQUATIONS

A different type of problem is one involving simultaneous algebraic equations. A system of two equations in two unknowns may be represented by the equations

$$a_1 x + b_1 y = c_1$$

$$a_2 x + b_2 y = c_2$$

These equations may be rewritten in the form

$$\frac{x}{b_1} + \frac{y}{a_1} = \frac{c_1}{a_1 b_1}$$

$$\frac{x}{b_2} + \frac{y}{a_2} = \frac{c_2}{a_2 b_2}$$

The computer circuit for these equations is shown in Figure 32.

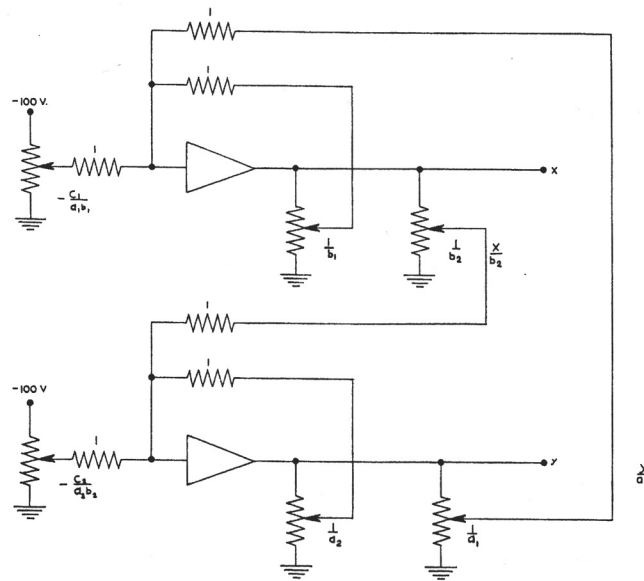

Figure 32

CIRCUIT FOR SIMULTANEOUS ALGEBRAIC EQUATIONS

As an example, consider the equations

$$5x + 3y = 210$$

$$2x + 5y = 160$$

These equations become

$$\frac{x}{3} + \frac{y}{5} = 14$$

$$\frac{x}{5} + \frac{y}{2} = 16$$

The computer circuit for these equations is shown in Figure 33.

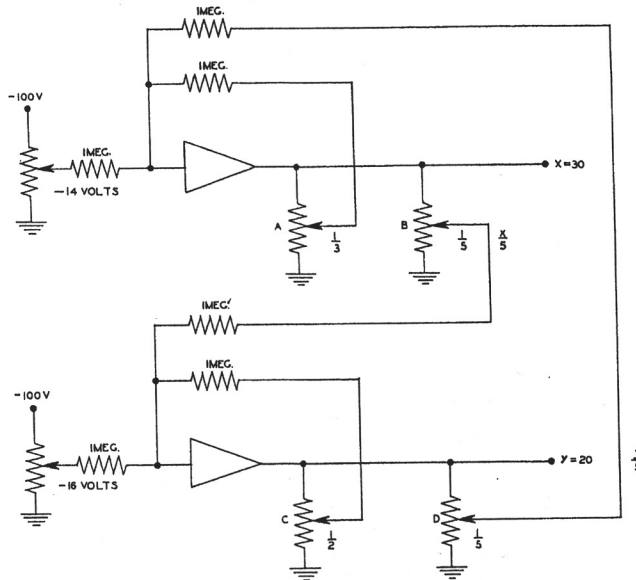

Figure 33

CIRCUIT FOR SIMULTANEOUS EQUATIONS

The values of x and y are read on the meter.

Control A is set so that the voltage drop between the center lugs and ground is 1/3 the voltage drop across the control. Control B is set so that the voltage drop between the center lug and ground is 1/5 the voltage drop across the control. Controls C and D are likewise set for 1/2 and 1/5 the total voltage respectively.

PROJECTILE PROBLEM

A variation of the falling body problem is to fire a projectile upward at an angle from the horizontal and see the path on the oscilloscope. * Air resistance may be introduced also. Thus the effects of the initial velocity, gravity and air resistance may be observed.

In the X direction, the equation of motion is

$$\frac{d^2x}{dt^2} = -\frac{c}{M} \frac{dx}{dt} \text{ with } \frac{dx}{dt} = v_{ox} \text{ at } t=0$$

and the equation in the Y direction is

$$\frac{d^2y}{dt^2} = -g - \frac{c}{M} \frac{dy}{dt} \text{ with } \frac{dy}{dt} = v_{oy} \text{ at } t=0$$

*The setup of this problem is presented here through the courtesy of Prof. Harry F. Meiners of the Department of Physics, Rensselaer Polytechnical Institute, Troy, New York.

The basic computer setup is shown in Figure 34.

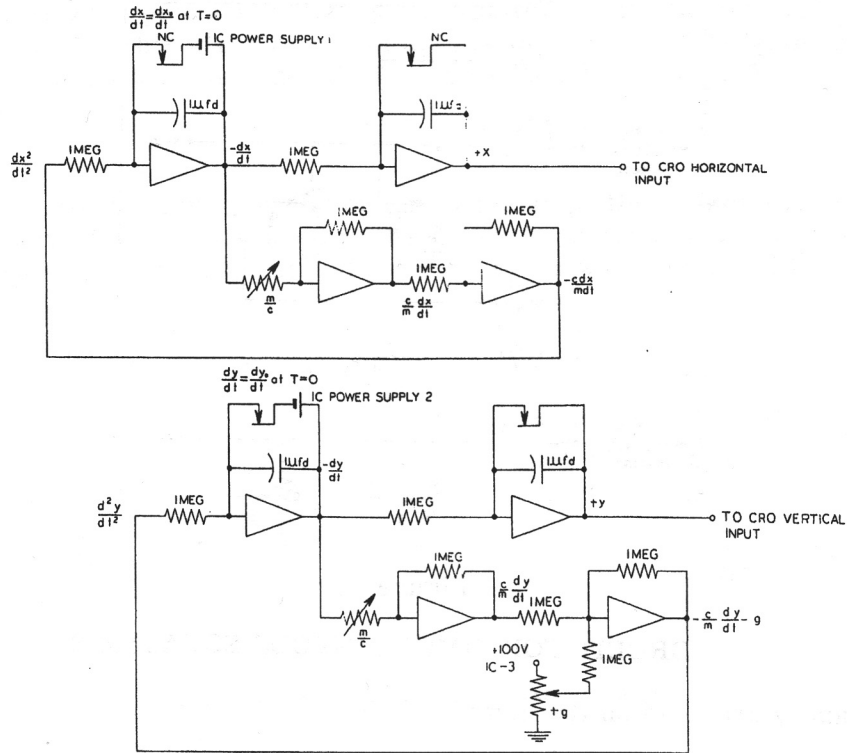

Figure 34

COMPUTER SETUP FOR PROJECTILE PROBLEM

The components of the initial velocity are controlled by IC-1 and IC-2, while the acceleration due to gravity, g , is controlled by IC-3. Air resistance is controlled by the controls m/c . The solution is shown in Figure 35.

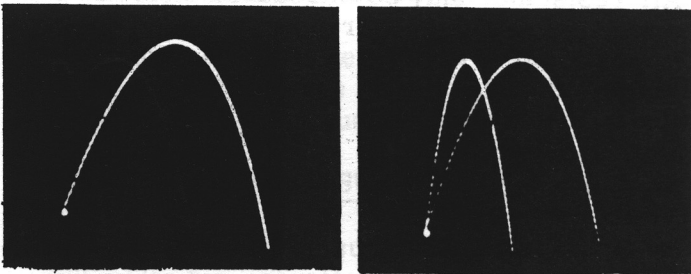

Figure 35 A

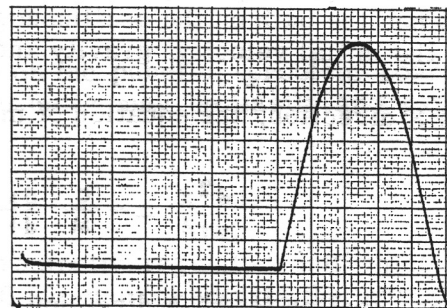

Figure 35 B

SOLUTION OF PROJECTILE PROBLEM

(a) As recorded on oscilloscope.

(b) As recorded on pen recorder

BOUNCING BALL

A problem which is interesting to watch, as well as one which illustrates the more complex type of problem that the computer is capable of handling, is the "Bouncing Ball" problem. For solving this problem, a few additional components are required which are readily obtained from most any dealer in radio supplies. The following additional components are needed:

- 1 20 K Ω (0.02 megohm) resistor
- 1 200 K Ω (0.2 megohm) resistor
- 1 500 K Ω (0.5 megohm) resistor
- 1 2 megohm resistor
- 1 5 megohm resistor
- 4 10 megohm resistors

The resistors should preferably be 1% tolerance, but 5% or even 10% resistors will be satisfactory for demonstration purposes. The potentiometers can be of the ordinary radio type. Silicon diodes are furnished with the computer. In addition to the above components, it is necessary to set up a phase shifter to produce the Lissajous pattern which simulates the ball. The parts required for the unit are:

- 1 6.3 V filament transformer (current rating not important but must have center tap)
- 2 10 K Ω , 1/2 watt resistors
- 2 25 K Ω controls
- 1 0.1 μ fd, 150 volt capacitor
- 1 1.0 μ fd, 150 volt capacitor
- 2 100 K Ω controls

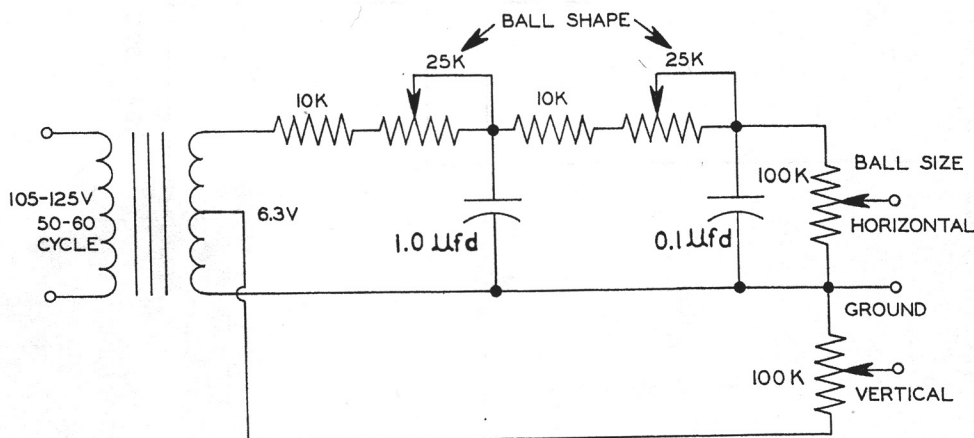

Figure 36

PHASE SHIFTER FOR BOUNCING BALL PROBLEM

These components are standard radio components. The capacitors may be paper or plastic tubular. The complete diagram for the problem, including the phase shifter, is shown in Figure 38. Any good DC oscilloscope may be used for observing the motion of the ball. The Heath DC Oscilloscope is especially suitable for use with the EC-1. The sweep circuit in the oscilloscope is not used, as the sweep voltage is provided by the computer. Solution is shown in Figure 37.

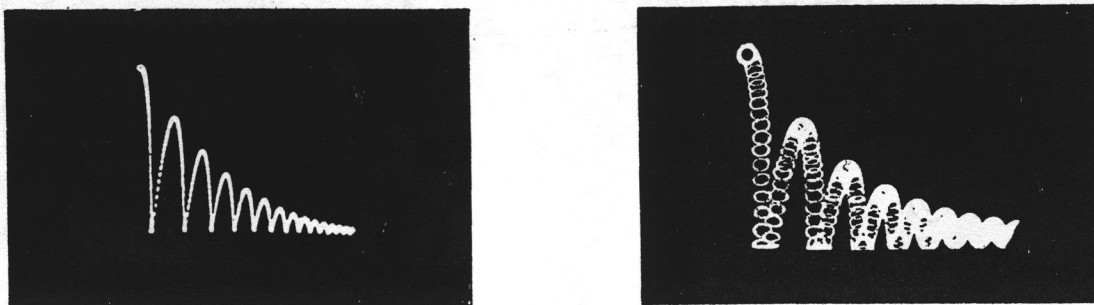

Figure 37

BOUNCING BALL PROBLEM AS SHOWN ON OSCILLOSCOPE

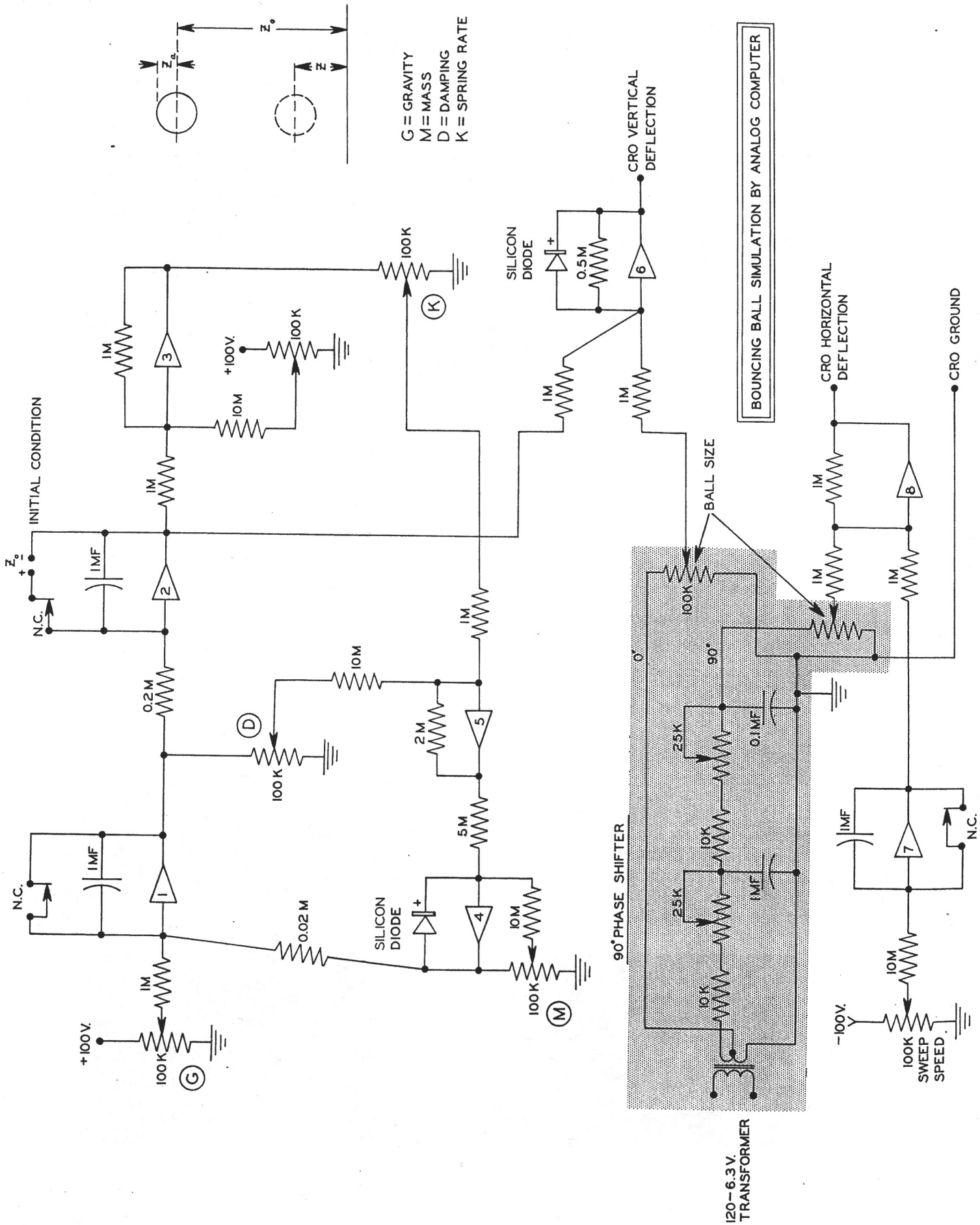

Figure 38

REFERENCE BOOKS

ANALOG COMPUTERS

- Goode, Harry H. and Machol, Robert E., SYSTEM ENGINEERING, McGraw-Hill, 1957.
- Johnson, Clarence L., ANALOG COMPUTER TECHNIQUES, McGraw-Hill, 1956.
- Karplus, Walter J., ANALOG SIMULATION, McGraw-Hill, New York, 1958.
- Korn, Granino A. and Korn, Theresa M., ELECTRONIC ANALOG COMPUTERS, Second Edition, McGraw-Hill, 1956.
- Paynter, H. M., A PALIMPSEST ON THE ELECTRONIC ANALOG ART, Geo. A. Philbrick Researches, Inc., 230 Congress Street, Boston, Massachusetts, 1955.
- Smith, George W. and Wood, Roger C., PRINCIPLES OF ANALOG COMPUTATION, McGraw-Hill, 1959.
- Soroka, Walter W., ANALOG METHODS IN COMPUTATION AND SIMULATION, McGraw-Hill, 1954.
- Wass, C. A. A., INTRODUCTION TO ELECTRONIC ANALOGUE COMPUTERS, McGraw-Hill, 1955.

ANALOG AND DIGITAL COMPUTERS

- Berkeley, Edmund C. and Wainwright, Lawrence, COMPUTERS - THEIR OPERATION AND APPLICATIONS, Reinhold, New York, 1956.
- Engineering Research Associates Staff, HIGH-SPEED COMPUTING DEVICES, McGraw-Hill, 1950.
- Ivall, T. E., ELECTRONIC COMPUTERS - PRINCIPLES AND APPLICATIONS, Philosophical Library, New York, 1956.
- Proceedings of the NATIONAL ELECTRONICS CONFERENCE, Volume V, 1949, Chicago, 1950.
- Stibitz, George R. and Larrivee, Jules A., MATHEMATICS AND COMPUTERS, McGraw-Hill, 1957.

PAMPHLETS

- Howe, C. E. and Howe, R. M., A TABLETOP ELECTRONIC DIFFERENTIAL ANALYZER, University of Michigan, Department of Aeronautical Engineering, Publication AIR-6, 1953.
- Martinez, Hugo, AN INTRODUCTION TO THE APPLICATION OF ELECTRONIC ANALOG COMPUTERS, Berkeley Division of Beckman Instruments Inc., 2200 Wright Avenue, Richmond 3, California.
- Nichols, M. H. and Hagelbarger, D. W., A SIMPLE ELECTRONIC DIFFERENTIAL ANALYZER AS A DEMONSTRATION AND LABORATORY AID TO INSTRUCTION IN ENGINEERING, University of Michigan, Department of Aeronautical Engineering, 1951.
- Haneman, V. S. Jr. and Howe, R. M., SOLUTION OF PARTIAL DIFFERENTIAL EQUATIONS BY DIFFERENCE METHODS USING THE ELECTRONIC DIFFERENTIAL ANALYZER, University of Michigan, Department of Aeronautical Engineering, Engineering Research Institute, Publication AIR-1, 1951.

ARTICLES

- Resnick, James B., "Scale Factors For Analog Computers", Product Engineering, March, 1954.

- Reque, S. G., "Simulate the System With an Analog Computer", Control Engineering, September, 1956, Pages 138-144.
- Heald, Carl, "Putting the Analog Computer to Work", ISA Journal, Vol. 3, No. 8, August 1956, Page 270.
- Howe, R. M., and Haneman, V. S., "Solution of Partial Differential Equations by Difference Methods Using the Electronic Differential Analyzer", Proceedings IRE, Vol. 41, No. 10, October, 1953.
- Strong, John D., "A Practical Approach to Analog Computers", Instruments and Automation, Vol. 28, No. 4, April, 1955.
- Symon, Keith R. and Poplawsky, Robert P., "An Electronic Differential Analyzer", American Journal of Physics, Vol. 21, No. 1, January 1953, Page 53.
- Martinez, Hugo M., "Operational Electronic Analog Computers", ISA Journal, March and April 1957.

JOURNAL

IRE TRANSACTIONS ON ELECTRONIC COMPUTERS, Published quarterly by The Institute of Radio Engineers, 1 East 79th Street, New York 21, New York.

SPECIFICATIONS

AMPLIFIERS

Nine DC operational amplifiers, each using a high gain circuit with a pentode driving a cathode follower output. Each amplifier has the following characteristics:

GAIN: Open loop gain approximately 1000.

OUTPUT: Any value between -60 and +60 volts with load current up to 0.7 ma.

HUM AND NOISE LEVEL: Approximately 4 mv referred to input, under normal conditions.

DRIFT: Short term drift less than ± 5 mv referred to input.

FREQUENCY RESPONSE: Down 1 db at 600 cps.

ADJUSTMENTS: Screwdriver adjust balance controls mounted on front panel. Amplifiers may be balanced without removing problem setup.

CONNECTIONS: Two input and two output connections for each amplifier. Computing components mount on plugs which are inserted in sockets on panel.

METER

A 50-0-50 microampere movement calibrated to read 1-0-1, 10-0-10 and 100-0-100 volts is used to read power supply voltage, measure initial condition voltages, monitor output of an amplifier, and indicate amplifier balance.

INITIAL CONDITION VOLTAGE SUPPLIES

Three ungrounded supplies, each of which provide 0-100 volts at 5 ma regulated by VR tube. May be used as positive or negative voltage source.

RELAYS

A relay with four sets of contacts provides for applying initial condition voltages and for re-setting problems.

REPETITIVE OPERATION

A multivibrator provides for automatic operation at from approximately 0.1 to 15 cps.

MAIN POWER SUPPLY

The positive supply is electronically regulated and provides +300 volts at 25 ma. The negative supply provides -150 volts at 40 ma and is regulated by a VR tube.

COEFFICIENT POTENTIOMETERS

Five 100 K Ω controls with terminals on panel.

COMPUTING COMPONENTS

Precision resistors, Mylar capacitors and patch cords are provided for setting up and solving many of the illustrative problems given in the Operational Manual.

DIMENSIONS

Computer Cabinet:..... 19 5/8" wide x 11 1/2" high x 15" deep.

Panel:..... 19" wide x 10 1/2" high. May be mounted in standard rack if desired.

WEIGHT

Net Weight:..... 37 1/2 lbs.

Shipping Weight:..... 43 lbs.

POWER REQUIREMENTS

105-125 volts, 50-60 cps, 100 watts.

ASSEMBLY TIME

Average about 25-30 hours. May require more or less time, depending on experience of builder and quality of workmanship.

OPERATION

This Operational Manual gives a discussion of Analog Computer theory and operation, instructions for operation of the EC-1 and directions for setting up and solving several illustrative problems.

APPLICATIONS

Teaching and demonstration in Engineering, Physics and Mathematics classes.

Laboratory use, especially in classes in analog computer design and use.

Industrial laboratories for preliminary runs of problems.

GRAPHS

The following graphs show the response of a typical DC amplifier of the EC-1. Individual amplifiers will show some variation from these curves.

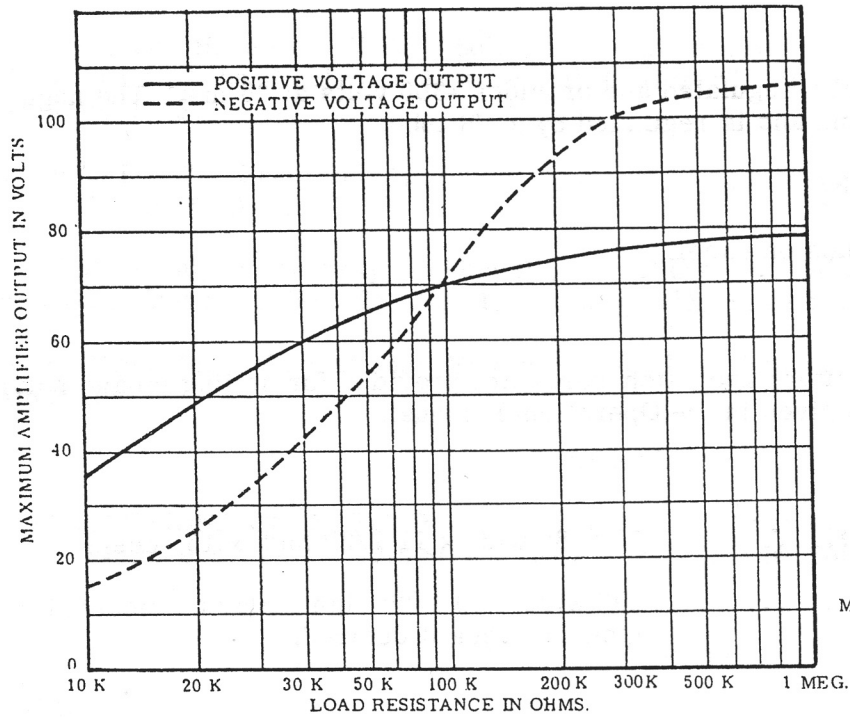

FIGURE 1
MAXIMUM OUTPUT VOLTAGE
AS A FUNCTION OF
LOAD RESISTANCE.

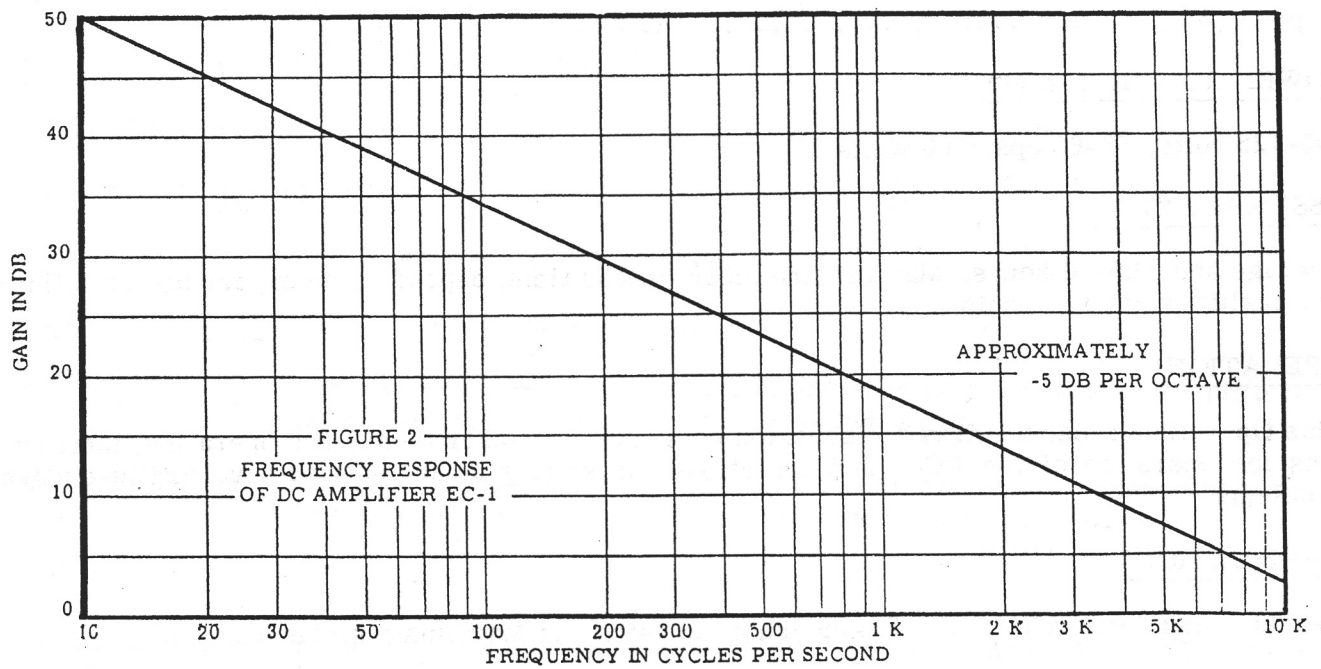
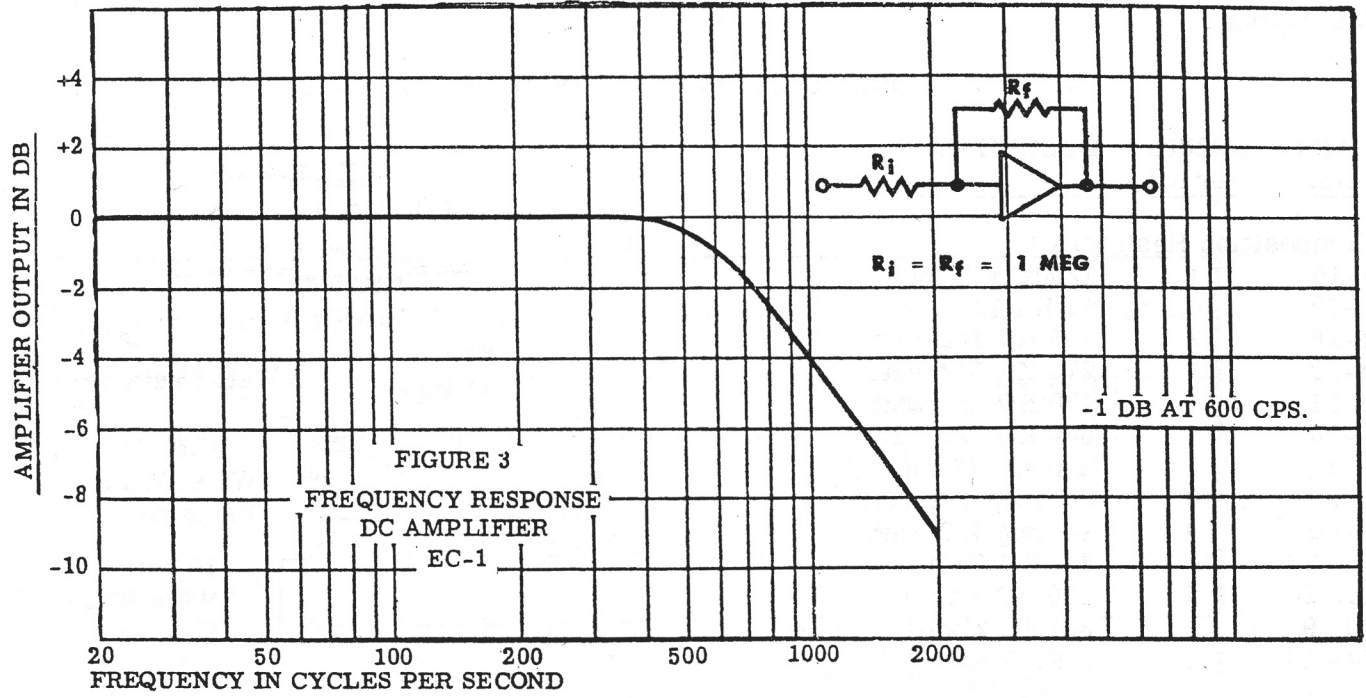

FIGURE 2
FREQUENCY RESPONSE
OF DC AMPLIFIER EC-1

APPROXIMATELY
-5 DB PER OCTAVE



To aid in the identification of parts, drawings of some of the parts are shown opposite the part description.

CONSTRUCTION COMPONENT PARTS LIST

PART No.	PARTS Per Kit	DESCRIPTION
Composition Resistors		
1-10	1	1200Ω 1/2 watt
1-69	10	18 KΩ 1/2 watt
1-26	2	100 KΩ 1/2 watt
1-30	1	270 KΩ 1/2 watt
1-33	1	470 KΩ 1/2 watt
1-34	9	680 KΩ 1/2 watt
1-35	1	1 meg 1/2 watt
1-37	10	2.2 meg 1/2 watt
1-40	9	10 meg 1/2 watt
1A-24	1	4.7 KΩ 1 watt
1A-28	9	100 KΩ 1 watt
1B-9	4	3.3 KΩ 2 watt
3G-14	1	2 KΩ 7 watt
3J-8	2	15 KΩ 10 watt



1/2 Watt Resistor



1 Watt Resistor

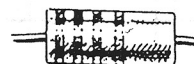

2 Watt Resistor

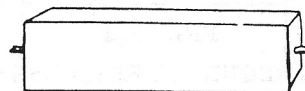

7 Watt Wire Wound Resistor

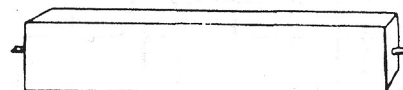

10 Watt Wire Wound Resistor

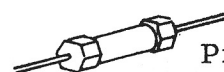

Precision Resistor

Precision Resistors

2-145	1	19 KΩ 1%
2-54	1	200 KΩ 1%
2-14	2	1 meg 1%
2-55	1	2 meg 1%
2-17	1	10 meg 1%

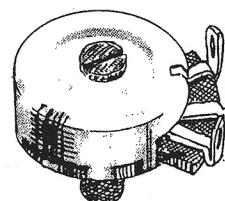

Linear Control Screwdriver Adjust

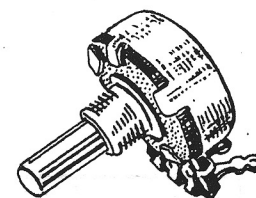

Linear Control Adjust

Controls-Switches

10-91	9	3 KΩ linear, screwdriver adjust
10-12	8	100 KΩ linear
10-14	1	250 KΩ linear
10-94	1	7.5 meg linear
60-3	9	DPDT slide switch
61-9	2	SPST toggle switch with hardware
63-190	1	3-position rotary switch
63-191	1	4-position rotary switch
63-192	1	12-position, 2-deck rotary switch

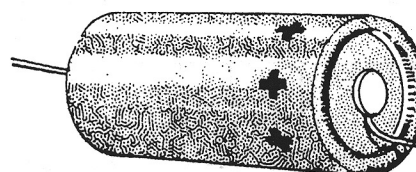

Tubular Electrolytic Capacitor

Capacitors

21-21	9	200 μmf 500 volt ceramic
23-3	1	0.01 μfd 400 volt plastic tubular
23-59	2	0.05 μfd 200 volt plastic tubular
23-28	1	0.1 μfd 200 volt plastic tubular
23-56	1	0.5 μfd 200 volt plastic tubular
25-30	1	20-20 μfd 350 volt electrolytic
25-41	6	40 μfd 350 volt electrolytic

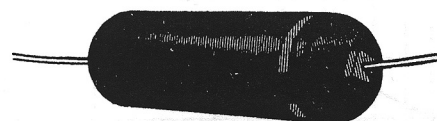

Plastic Molded Paper Capacitor



Ceramic Capacitor

PART No.	PARTS Per Kit	DESCRIPTION
----------	---------------	-------------

Sockets-Terminal Strips-Knobs

434-15	7	7-pin miniature wafer socket
434-16	10	9-pin miniature wafer socket
434-38	27	Crystal socket
434-22	1	Pilot lamp assembly, green
434-69	1	Pilot lamp assembly, clear
431-1	8	1-lug terminal strip
431-2	13	2-lug terminal strip
431-3	1	3-lug terminal strip
431-10	9	3-lug terminal strip
431-27	1	3-lug terminal strip
431-5	6	4-lug terminal strip
431-45	1	6-lug terminal strip
462-13	1	Small black knob
462-52	12	Black knob, indexed

Transformers-Rectifiers

54-76	1	Filament transformer
54-78	1	Plate transformer
57-13	7	50 ma selenium rectifier
57-27	6	500 ma silicon rectifier

Meter-Tubes-Lamps

407-58	1	50-0-50 microampere meter with mounting hardware
411-46	4	OB2 tube
411-59	1	OA2 tube
411-60	1	6AQ5 tube
411-73	1	12BH7 tube
411-80	9	6U8 tube
411-95	1	6BH6 tube
412-1	1	#47 pilot lamp
412-15	18	NE-2H neon lamp
412-3	1	NE-51 neon lamp

Grommets-Bushings-Clamps

73-4	18	3/16" rubber grommet
73-2	4	3/4" rubber grommet
75-17	146	Nylon bushing
75-24	1	Plastic strain relief bushing
207-5	2	3/16" plastic cable clamp
207-8	1	Metal cable clamp
207-19	1	5/16" plastic cable clamp

Wire-Cable-Sleeving

340-2	1	Roll #20 bare wire
340-3	1	Roll #16 bare wire
340-1	1	Roll #14 bare wire
344-52	1	Red hookup wire
344-53	1	Orange hookup wire
344-54	1	Yellow hookup wire
344-55	1	Green hookup wire
344-56	1	Blue hookup wire

2-pin Socket

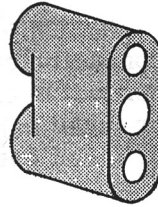

2-lug Terminal Strip

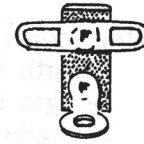

1-lug Terminal Strip

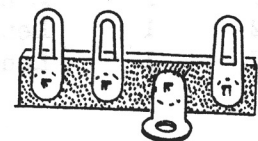
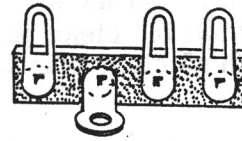

3-lug Terminal Strip 431-3

3-lug Terminal Strip 431-27

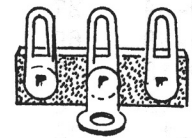

Silicon Rectifier 57-27

3-lug Terminal Strip 431-10

Line Cord Strain Relief Bushing

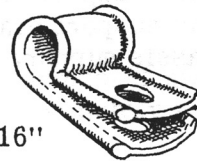

3/16"

Plastic Cable Clamp

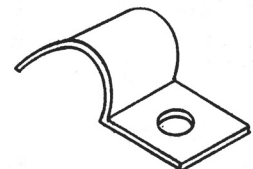

Metal Cable Clamp



5/16" Plastic Cable Clamp

PART No.	PARTS Per Kit	DESCRIPTION
----------	---------------	-------------

Wire-Cable-Sleeving (con't.)

347-7	1	Length 4-conductor cable
347-1	1	Length 8-conductor cable
134-2	1	8-conductor laced cable assembly
134-3	1	9-conductor laced cable assembly
89-1	1	Line cord
346-1	1	Length insulating sleeving
346-2	1	Length 3/16" clear plastic sleeving
346-7	1	Length #5 clear plastic sleeving (largest)

Hardware



250-63	2	3-48 x 1/8" round head machine screw
250-49	34	3-48 x 1/4" binding head machine screw
250-34	27	4-40 x 1/2" round head machine screw
250-89	69	6-32 x 3/8" binding head machine screw
250-18	12	8-32 x 3/8" round head machine screw
250-126	8	10-32 x 1/2" truss head machine screw
252-1	34	3-48 x 3/16" hex nut
252-2	27	4-40 x 1/4" hex nut
252-3	131	6-32 x 1/4" hex nut
252-4	12	8-32 x 5/16" hex nut
252-7	22	3/8" hex control nut
253-10	22	3/8" flat control washer
253-30	2	1/2" flat switch washer
254-1	87	#6 lockwasher
254-2	12	#8 lockwasher
254-4	22	3/8" control lockwasher
259-1	92	#6 solder lug

 3-48 BHMS  3-48 Nut

 4-40 RHMS  4-40 Nut

 6-32 Nut

 6-32 BHMS

 8-32 RHMS  8-32 Nut

 10-32 THMS

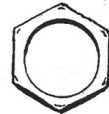

3/8" Control Nut

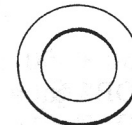

3/8" Control Washer



1/2" Flat Switch Washer



#6 Lockwasher



#8 Lockwasher

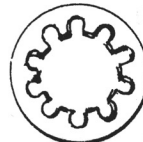

3/8" Control Lockwasher

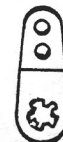

#6 Solder Lug

Sheet Metal Parts

200-M201	1	Chassis
203-M167F245	1	Panel
204-M219	1	Right panel support bracket
204-M220	1	Left panel support bracket
204-M221	1	Rear chassis support
90-97	1	Cabinet

Miscellaneous

69-9	1	Relay
423-1	1	Fuse post assembly
421-2	1	3 amp fuse
427-3	73	Binding post base
100-M16B	28	Black binding post cap
100-M16R	45	Red binding post cap
261-6	4	Rubber feet
331-6		Solder
595-234	1	Construction manual
595-235	1	Operational manual

PROBLEM SOLVING COMPONENTS PART LIST

PART No.	PARTS Per Kit	DESCRIPTION
2-11	9	100 K Ω 1% precision resistor
2-14	9	1 meg 1% precision resistor
27-1	3	0.1 μ fd 200 volt 5% mylar capacitor
27-2	3	1.0 μ fd 200 volt 5% mylar capacitor
56-24	2	Silicon diode
438-10	27	Plastic double plug
438-13	48	Banana plug
70-6	48	Red banana plug cap
341-2	1	Roll red test lead wire

SILICON
DIODE

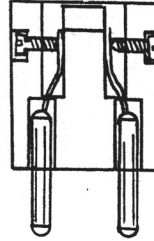
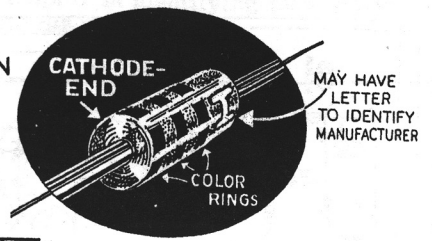

PLASTIC
DOUBLE PLUG

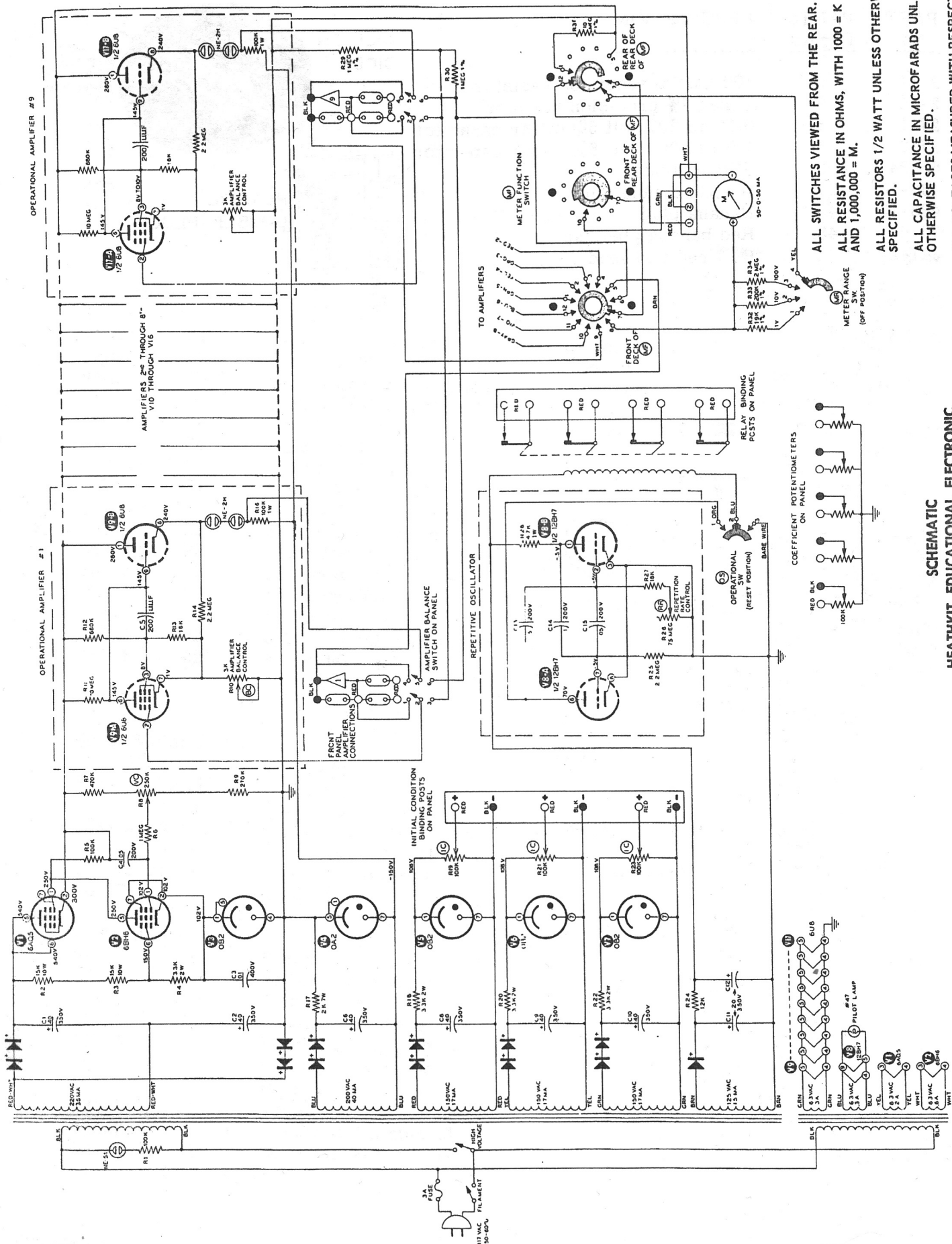











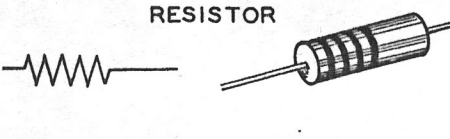
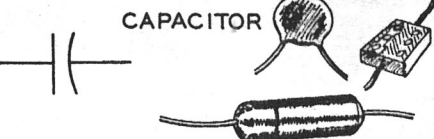
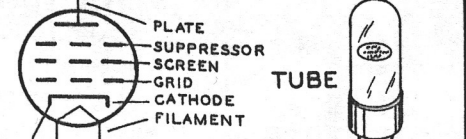
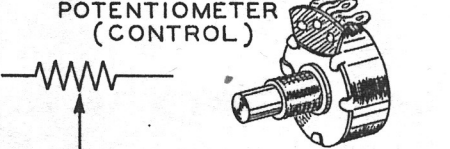

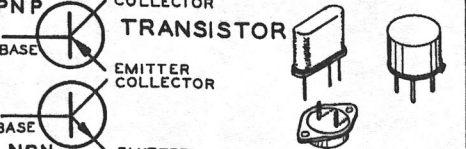
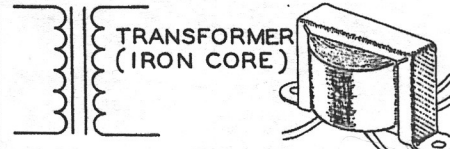

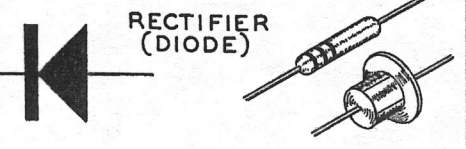
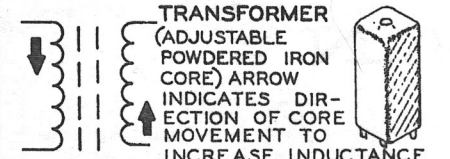
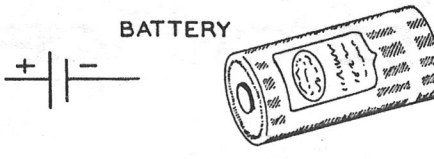
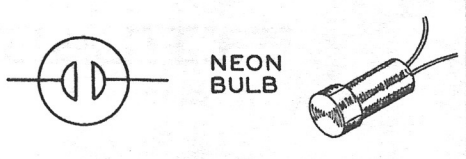
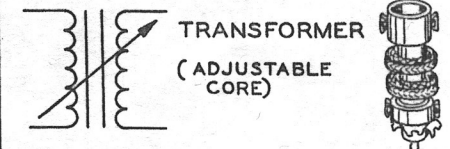
ALL SWITCHES VIEWED FROM THE REAR.
 ALL RESISTORS IN OHMS, WITH 1000 = K
 AND 1,000,000 = M.
 ALL RESISTORS 1/2 WATT UNLESS OTHERWISE
 SPECIFIED.
 ALL CAPACITANCE IN MICROFARADS UNLESS
 OTHERWISE SPECIFIED.
 ALL VOLTAGES MEASURED WITH RESPECT TO
 CHASSIS GROUND EXCEPT INITIAL CONDITION
 POWER SUPPLIES WHICH ARE MEASURED WITH
 RESPECT TO THE NEGATIVE OF THE POWER
 SUPPLY.

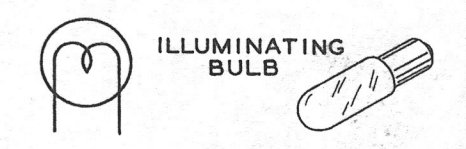
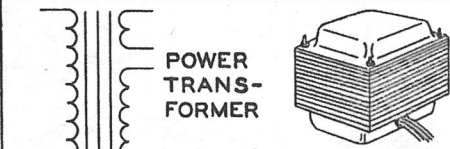
SCHEMATIC
HEATHKIT EDUCATIONAL ELECTRONIC
ANALOG COMPUTER
MODEL EC-1

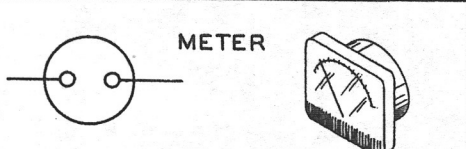
TYPICAL COMPONENT TYPES

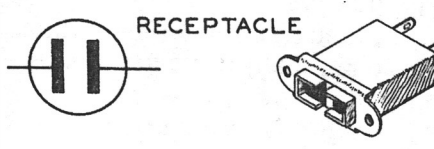
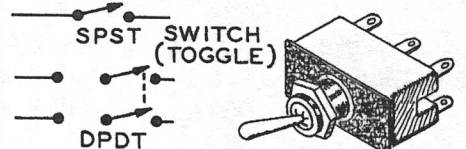
This chart is a guide to commonly used types of electronic components. The symbols and related illustrations

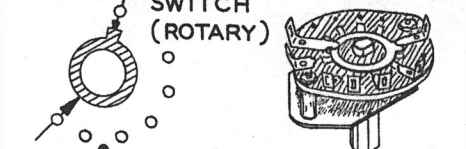
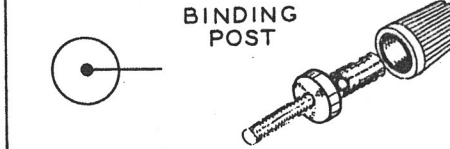
should prove helpful in identifying most parts and reading the schematic diagrams.

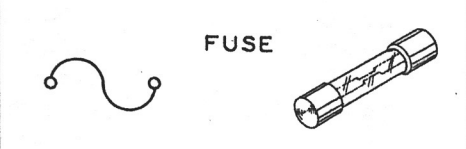
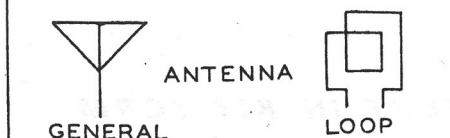
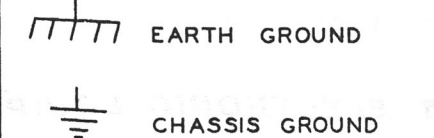
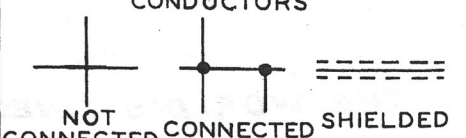
<p style="text-align: center;">RESISTOR</p> 	<p style="text-align: center;">CAPACITOR</p> 	<p style="text-align: center;">TUBE</p> 
<p style="text-align: center;">POTENTIOMETER (CONTROL)</p> 	<p style="text-align: center;">ELECTROLYTIC CAPACITOR</p> 	<p style="text-align: center;">TRANSISTOR</p> 
<p style="text-align: center;">TRANSFORMER (IRON CORE)</p> 	<p style="text-align: center;">VARIABLE CAPACITOR</p> 	<p style="text-align: center;">RECTIFIER (DIODE)</p> 
<p style="text-align: center;">TRANSFORMER (ADJUSTABLE POWDERED IRON CORE) ARROW INDICATES DIRECTION OF CORE MOVEMENT TO INCREASE INDUCTANCE</p> 	<p style="text-align: center;">BATTERY</p> 	<p style="text-align: center;">NEON BULB</p> 
<p style="text-align: center;">TRANSFORMER (ADJUSTABLE CORE)</p> 	<p style="text-align: center;">PHONO JACK</p> 	<p style="text-align: center;">ILLUMINATING BULB</p> 
<p style="text-align: center;">POWER TRANSFORMER</p> 	<p style="text-align: center;">PHONE JACK</p> 	<p style="text-align: center;">METER</p> 
<p style="text-align: center;">INDUCTOR (COIL)</p> 	<p style="text-align: center;">RECEPTACLE</p> 	<p style="text-align: center;">SWITCH (TOGGLE)</p> 
<p style="text-align: center;">PIEZOELECTRIC CRYSTAL</p> 	<p style="text-align: center;">SPEAKER</p> 	<p style="text-align: center;">SWITCH (ROTARY)</p> 
<p style="text-align: center;">BINDING POST</p> 	<p style="text-align: center;">MICROPHONE</p> 	<p style="text-align: center;">FUSE</p> 
<p style="text-align: center;">ANTENNA</p> 	<p style="text-align: center;">EARTH GROUND</p> <p style="text-align: center;">CHASSIS GROUND</p> 	<p style="text-align: center;">CONDUCTORS</p> 

HEATH COMPANY

BENTON HARBOR MICHIGAN

THE WORLD'S FINEST ELECTRONIC EQUIPMENT IN KIT FORM